

[54] **MOTOR DRIVEN TOY FLOWER**

[75] **Inventor: Isamu Kataoka, Ichikawa, Japan**

[73] **Assignee: Takara Co., Ltd., Tokyo, Japan**

[**] **Term: 14 Years**

[21] **Appl. No.: 318,359**

[22] **Filed: Mar. 3, 1989**

[30] **Foreign Application Priority Data**

Dec. 27, 1988 [JP] Japan 63-51443

[52] **U.S. Cl. D21/150**

[58] **Field of Search** D21/59, 109, 150, 168,
 D21/155, 148; 446/175, 303, 390; 272/8 N, 27
 N; 428/12, 24; 40/411, 414; D11/117, 153, 143;
 D10/9; D23/367

[56] **References Cited**

U.S. PATENT DOCUMENTS

D. 147,852 11/1947 Hyman D21/65

D. 190,499 6/1961 Hedgecock D11/152

D. 193,155 7/1962 Goodman et al. D11/117
 D. 223,313 4/1972 White D11/117
 1,938,736 12/1933 Berman D11/117
 2,810,176 10/1957 Gaafar D11/152
 4,903,424 2/1990 Satoh et al. 428/24

Primary Examiner—Charles A. Rademaker
Attorney, Agent, or Firm—Price, Gess & Ubell

[57] **CLAIM**

The ornamental design for a motor driven toy flower, as shown and described.

DESCRIPTION

FIG. 1 is a front perspective view of a motor driven toy flower showing my new design;
 FIG. 2 is a front elevational view thereof;
 FIG. 3 is a right side elevational view thereof;
 FIG. 4 is a left side elevational view thereof;
 FIG. 5 is a rear elevational view thereof;
 FIG. 6 is a top plan view thereof;
 FIG. 7 is a bottom plan view thereof and,
 FIG. 8 is a front perspective view of a modified embodiment of the design shown in FIGS. 1 through 7.

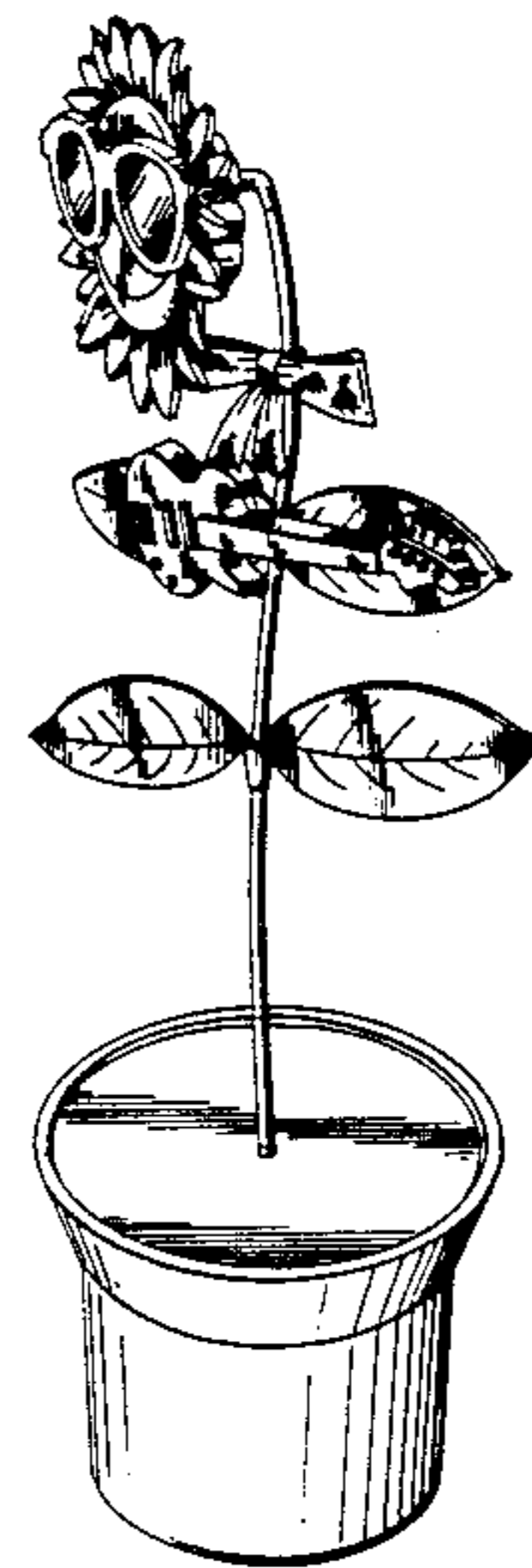
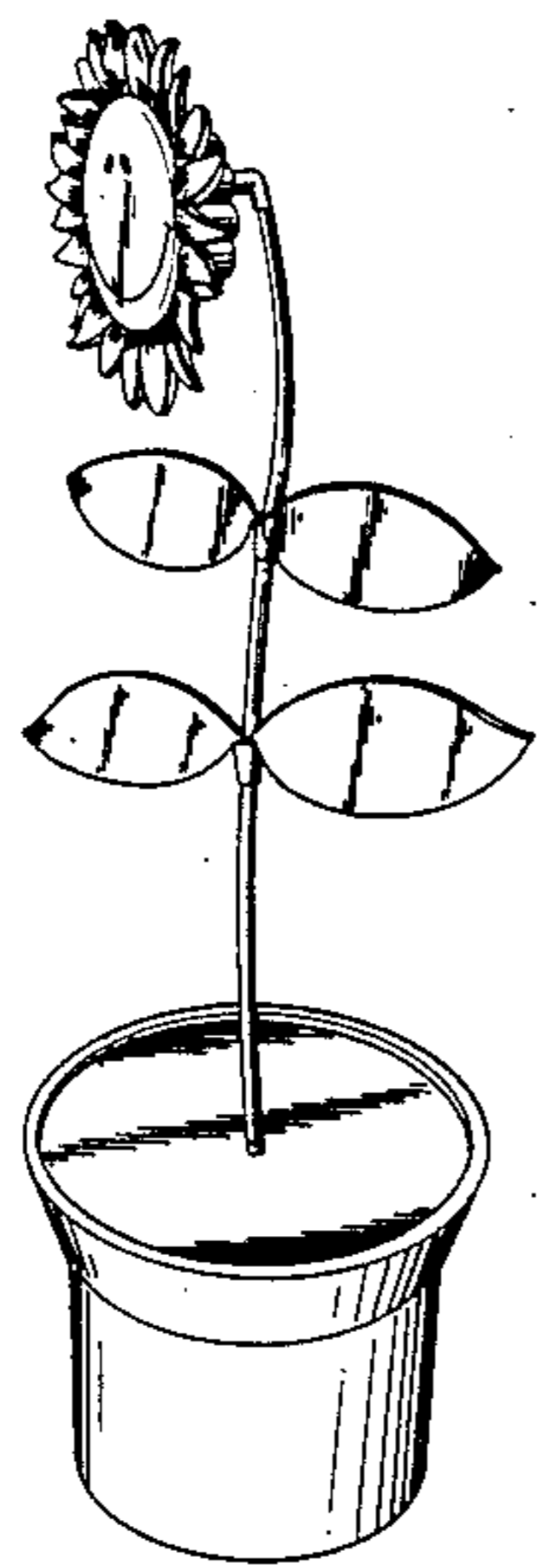

FIG. 1

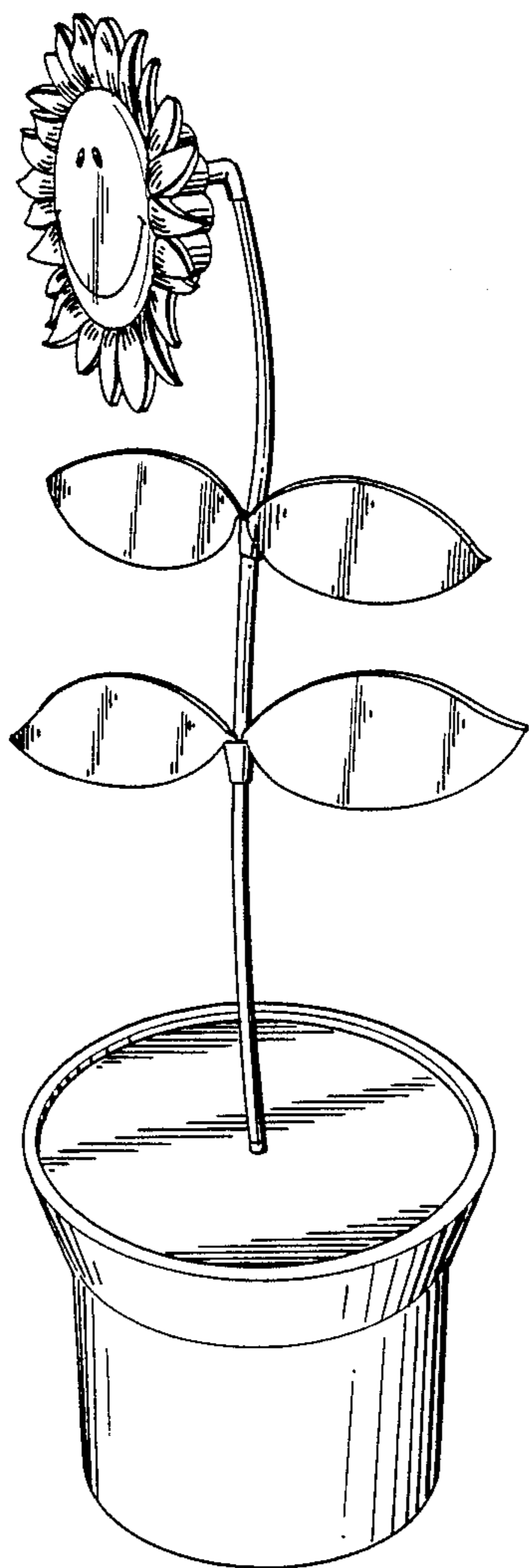

FIG. 2

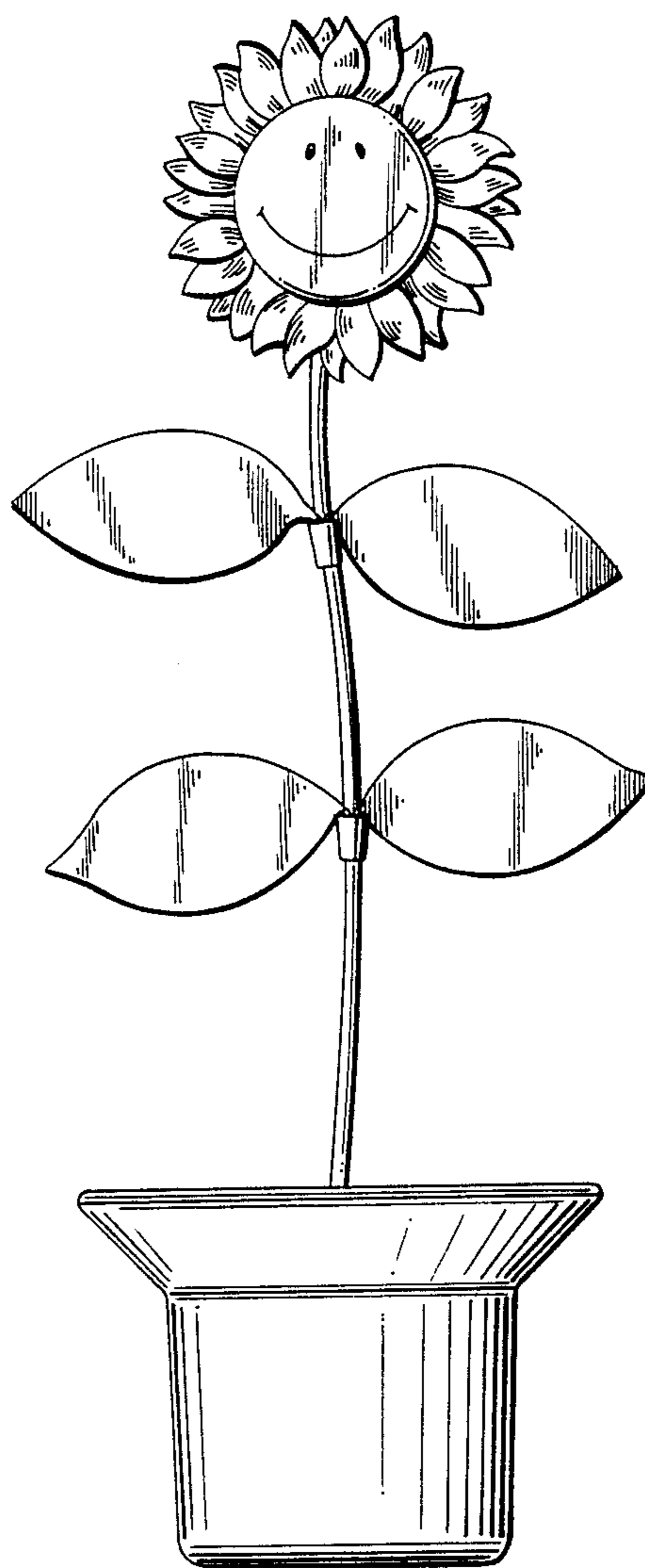

FIG. 3

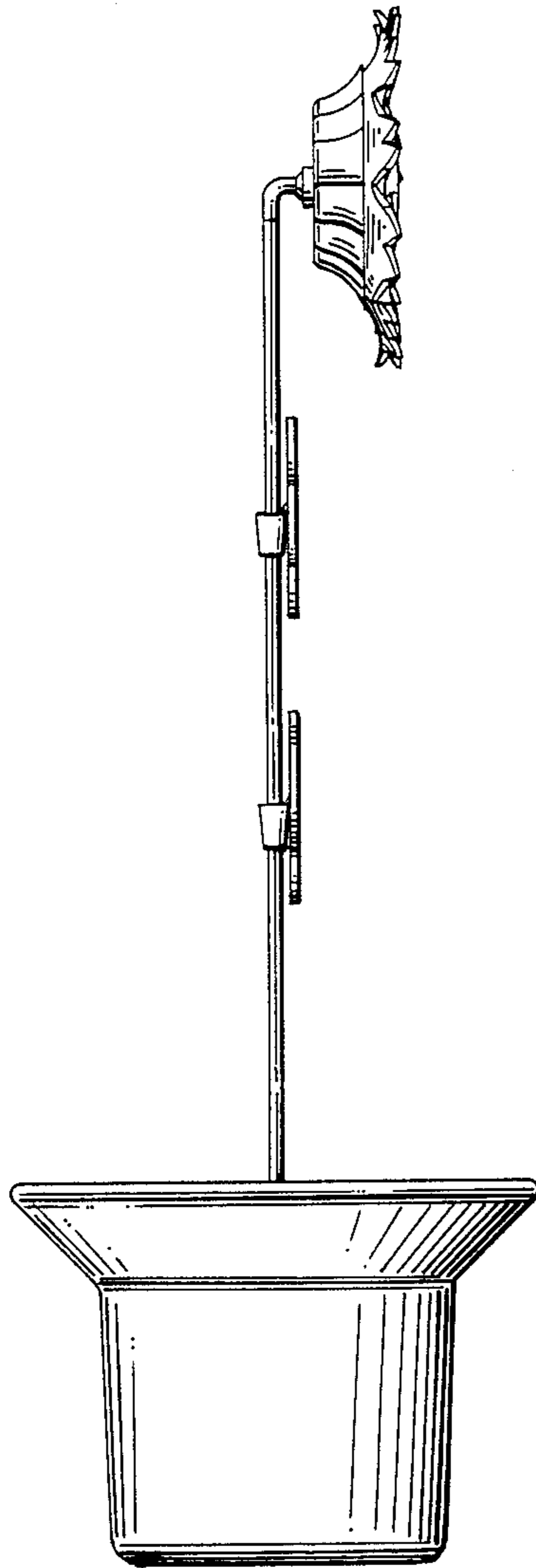

FIG. 4

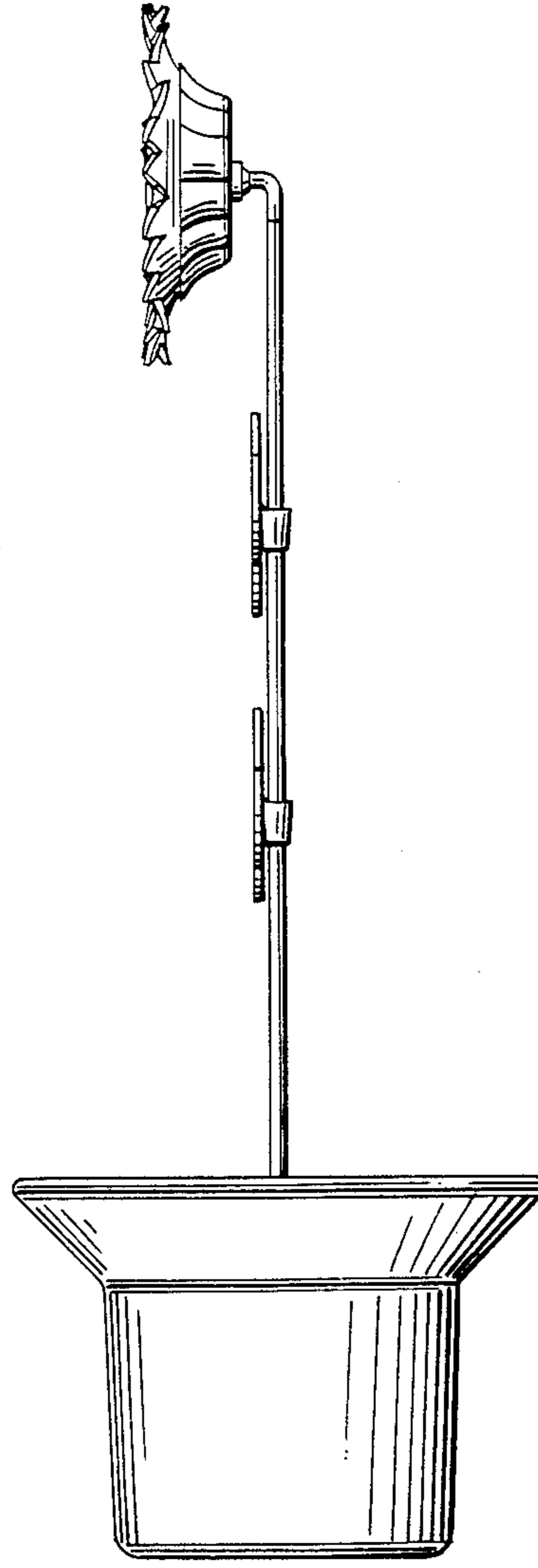

FIG. 5

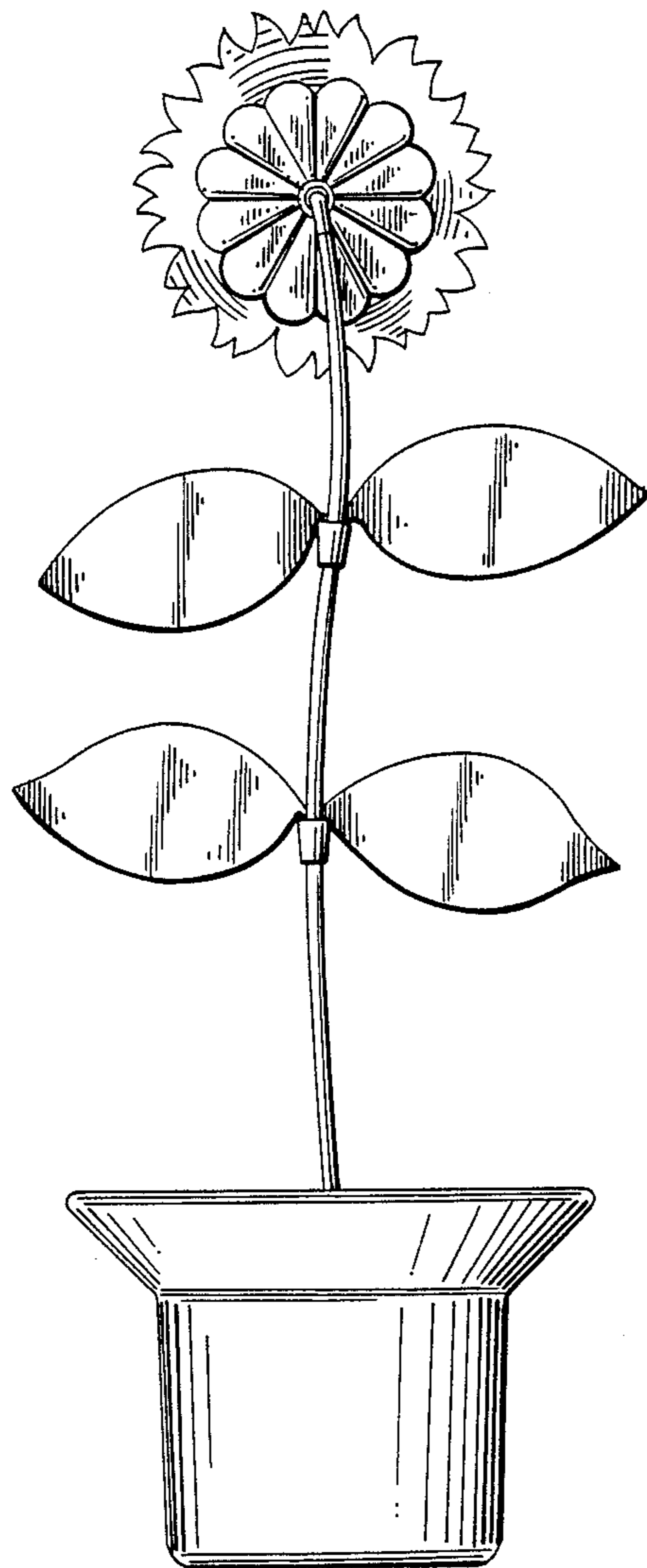

FIG. 6

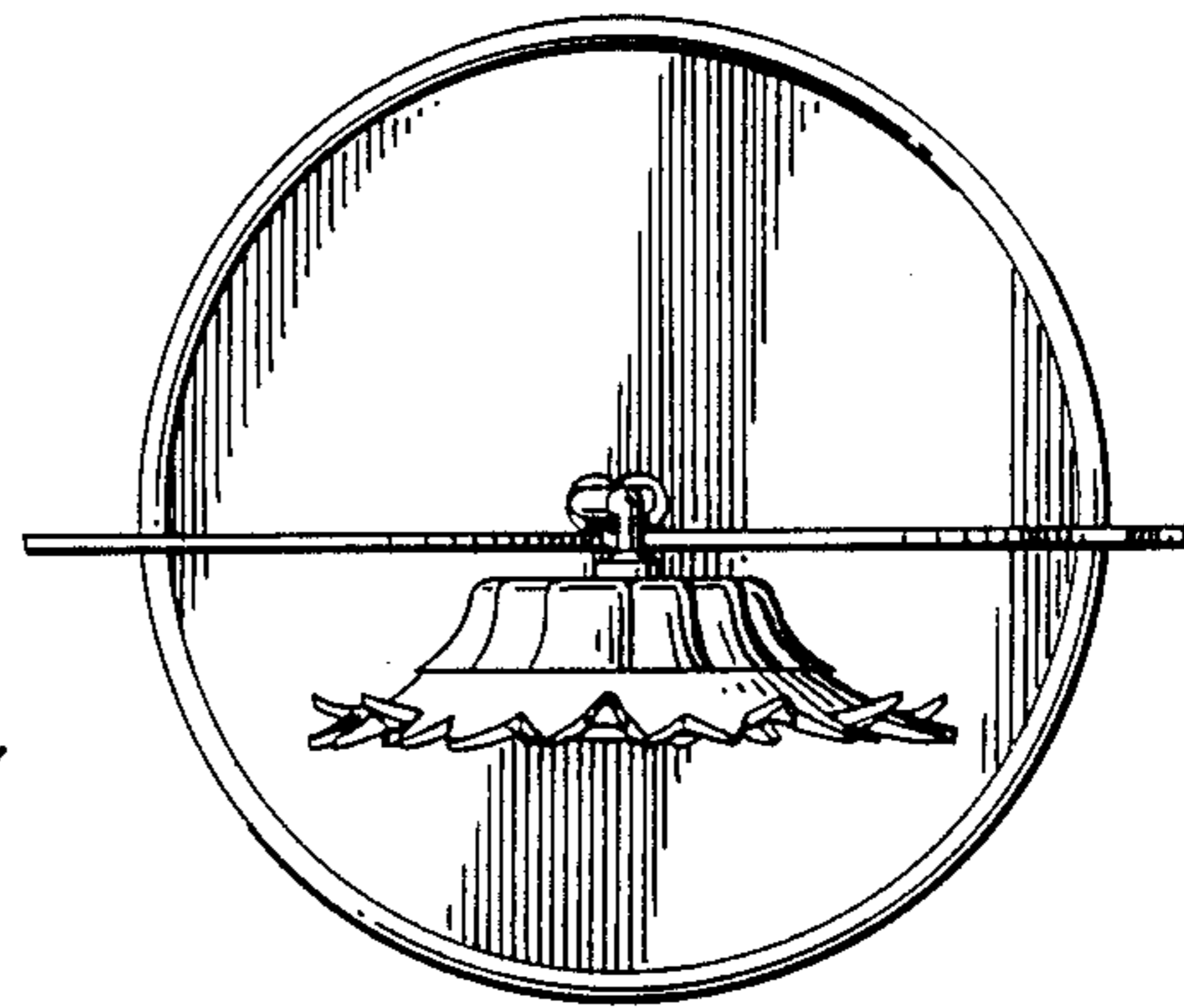

FIG. 7

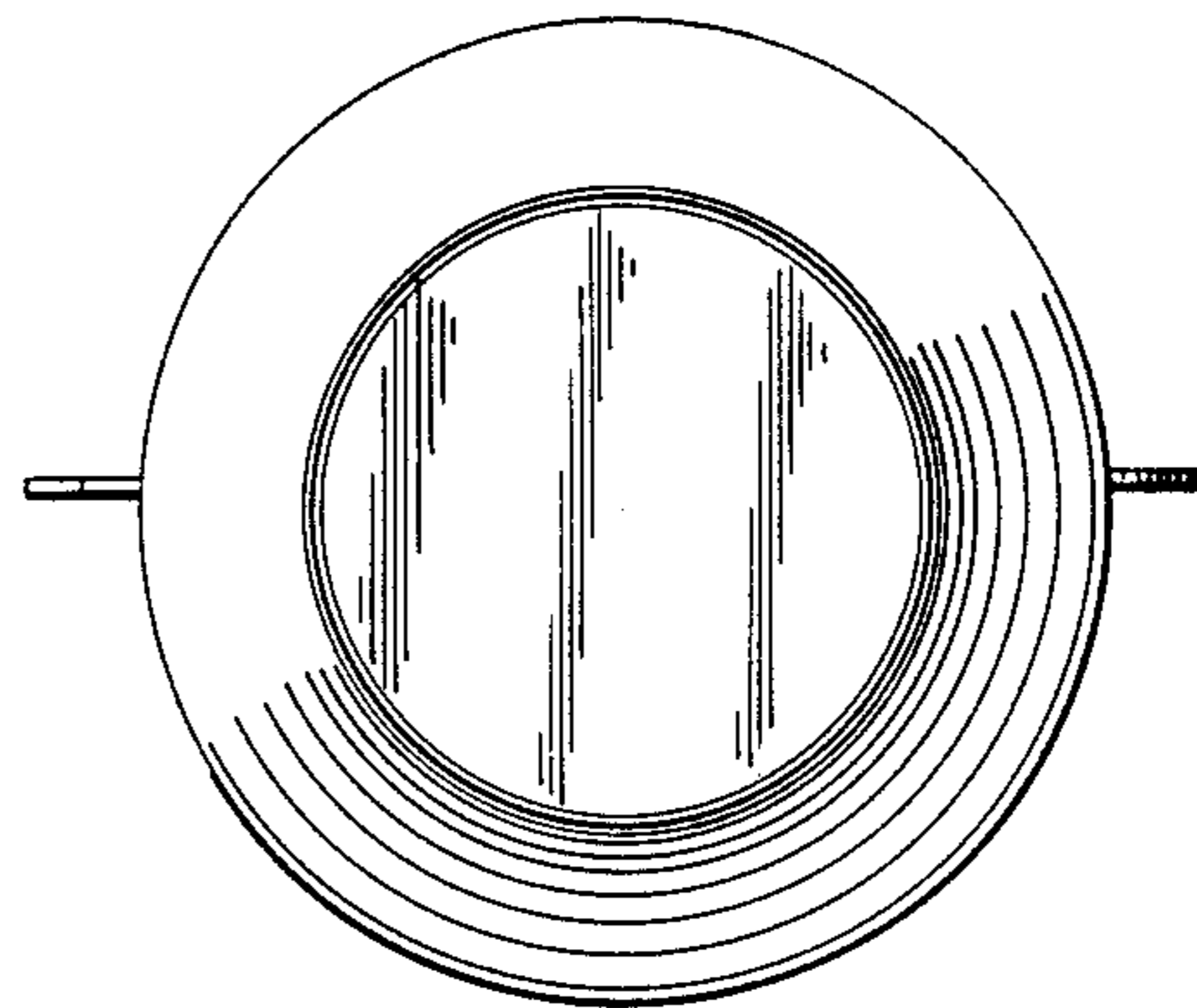

FIG. 8

