

[54] MOTORBOAT

[75] Inventor: Seiichi Ino, Akashi, Japan

[73] Assignee: Kawasaki Jukogyo Kabushiki Kaisha,  
Japan

[\*\*] Term: 14 Years

[21] Appl. No.: 269,164

[22] Filed: Nov. 9, 1988

[30] Foreign Application Priority Data

Jun. 27, 1988 [JP] Japan ..... 63-25479

[52] U.S. Cl. .... D12/307; D12/314

[58] Field of Search ..... D12/300, 307, 314, 313,  
D12/310, 311; 114/270

[56] References Cited

U.S. PATENT DOCUMENTS

D. 289,991 5/1987 Suzuki et al. .... D12/300

FOREIGN PATENT DOCUMENTS

285192 12/1986 Japan ..... 114/270

122893 6/1987 Japan ..... 114/270

Primary Examiner—Kay H. Chin

Attorney, Agent, or Firm—Leydig, Voit & Mayer

[57] CLAIM

The ornamental design for a motorboat, as shown and described.

DESCRIPTION

FIG. 1 is a front elevational view of a motorboat showing my new design;

FIG. 2 is a rear elevational view;

FIG. 3 is a top plan view;

FIG. 4 is a bottom plan view;

FIG. 5 is a left side elevational view;

FIG. 6 is a right side elevational view;

FIG. 7 is a front, right side and top perspective view;

FIG. 8 is a sectional view taken along line VIII—VIII of FIG. 1 when the inner structure has been omitted, and

FIG. 9 is a sectional view taken along line IX—IX of FIG. 6 when the inner structure has been omitted, and

FIG. 10 is a sectional view thereof taken along line X—X of FIG. 6 when the inner structure has been omitted.

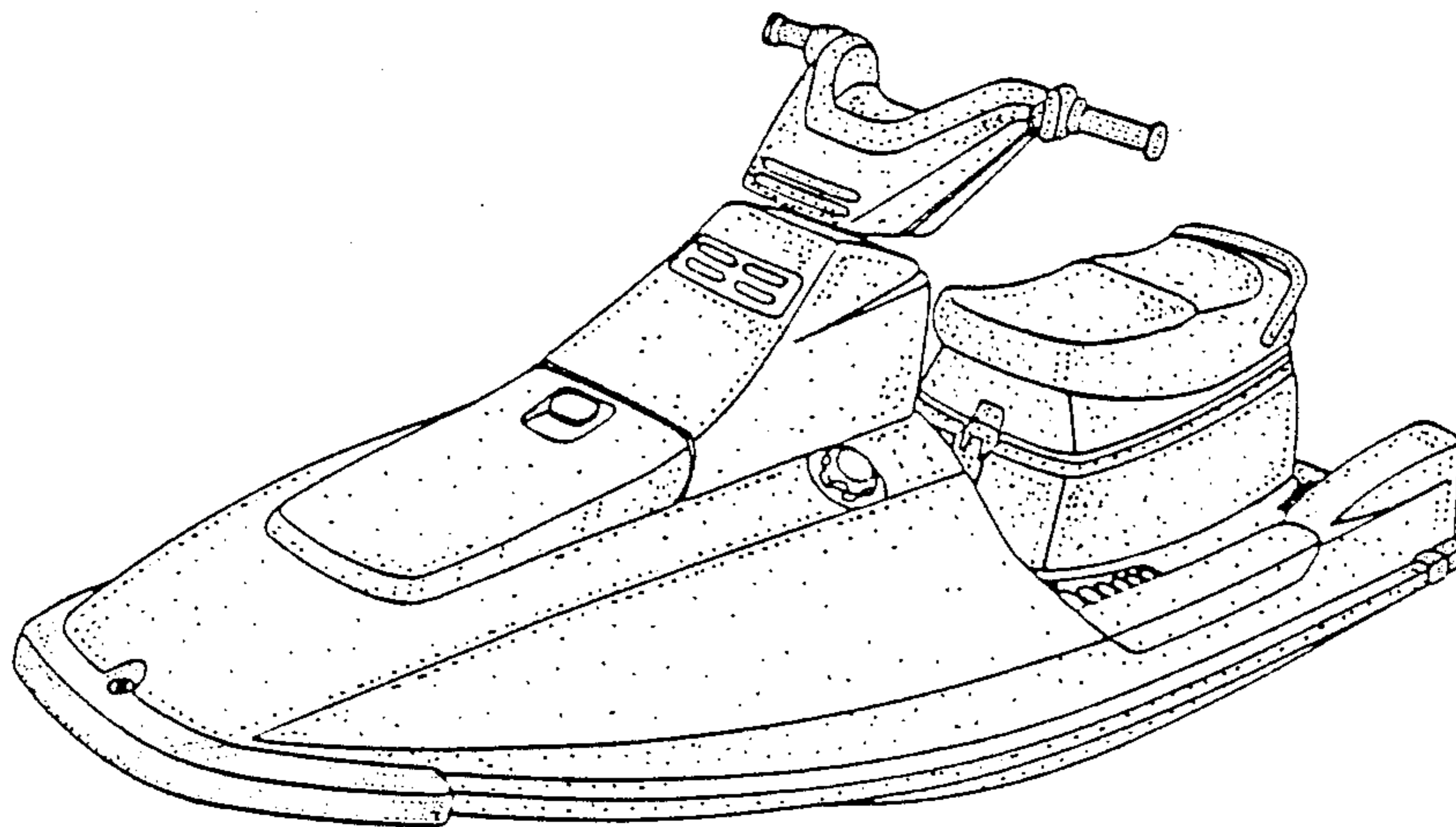

FIG. 1

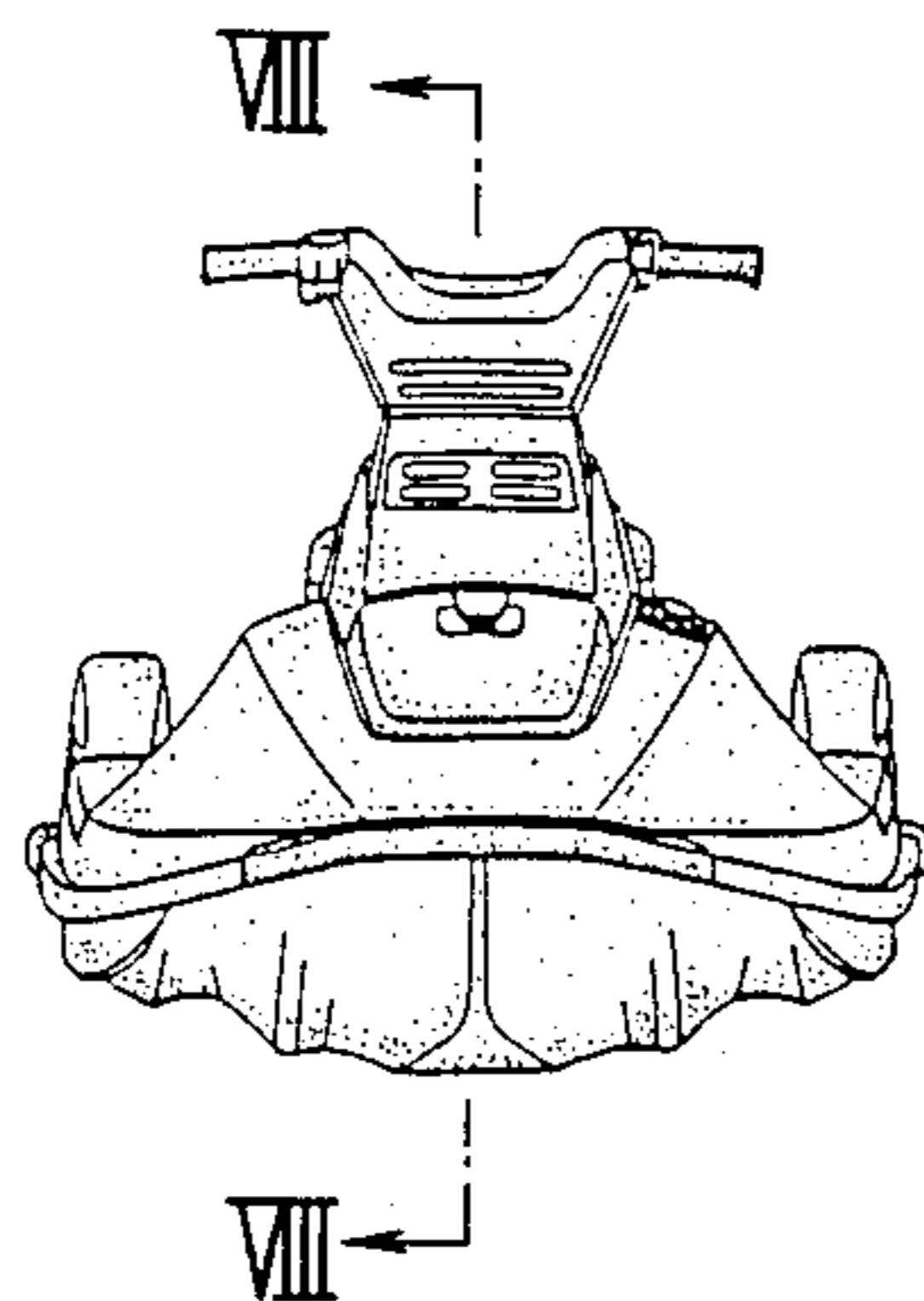

FIG. 2

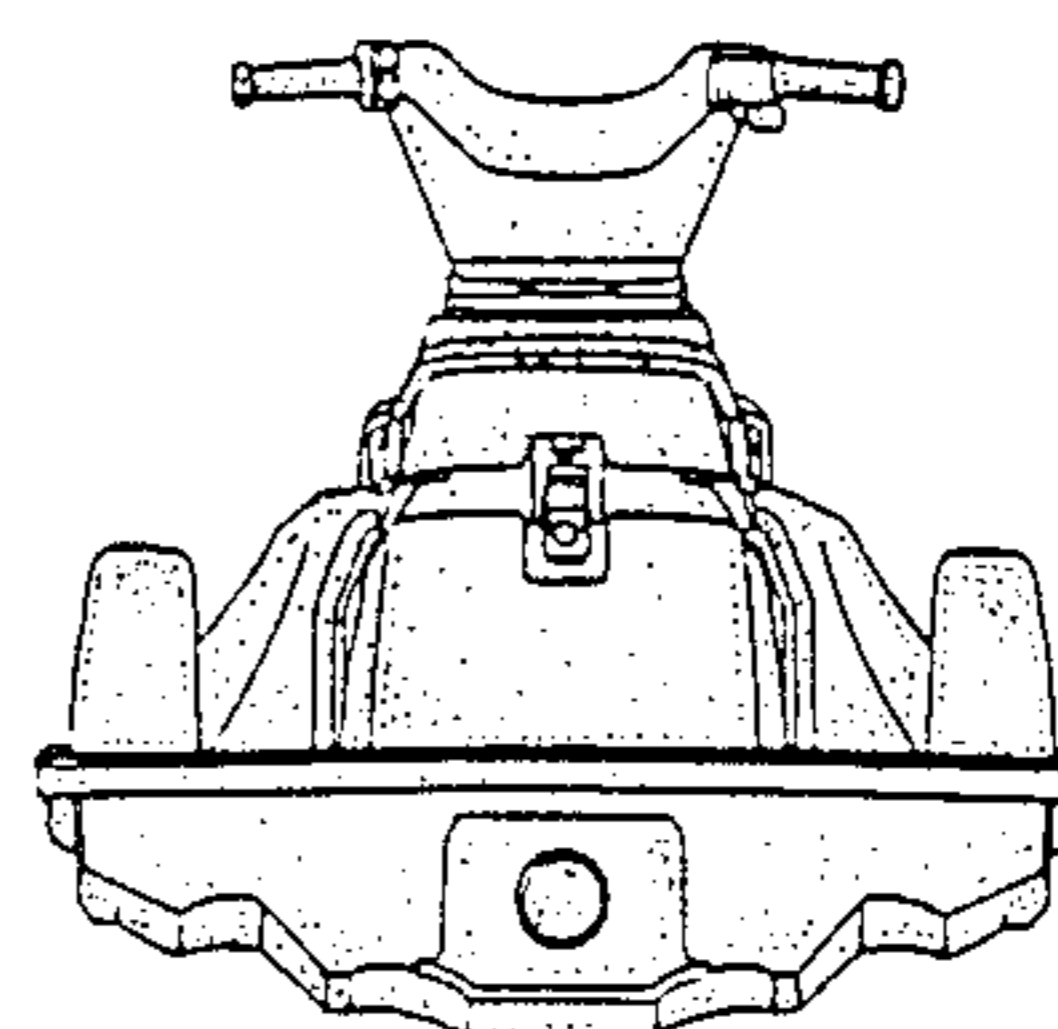

FIG. 3

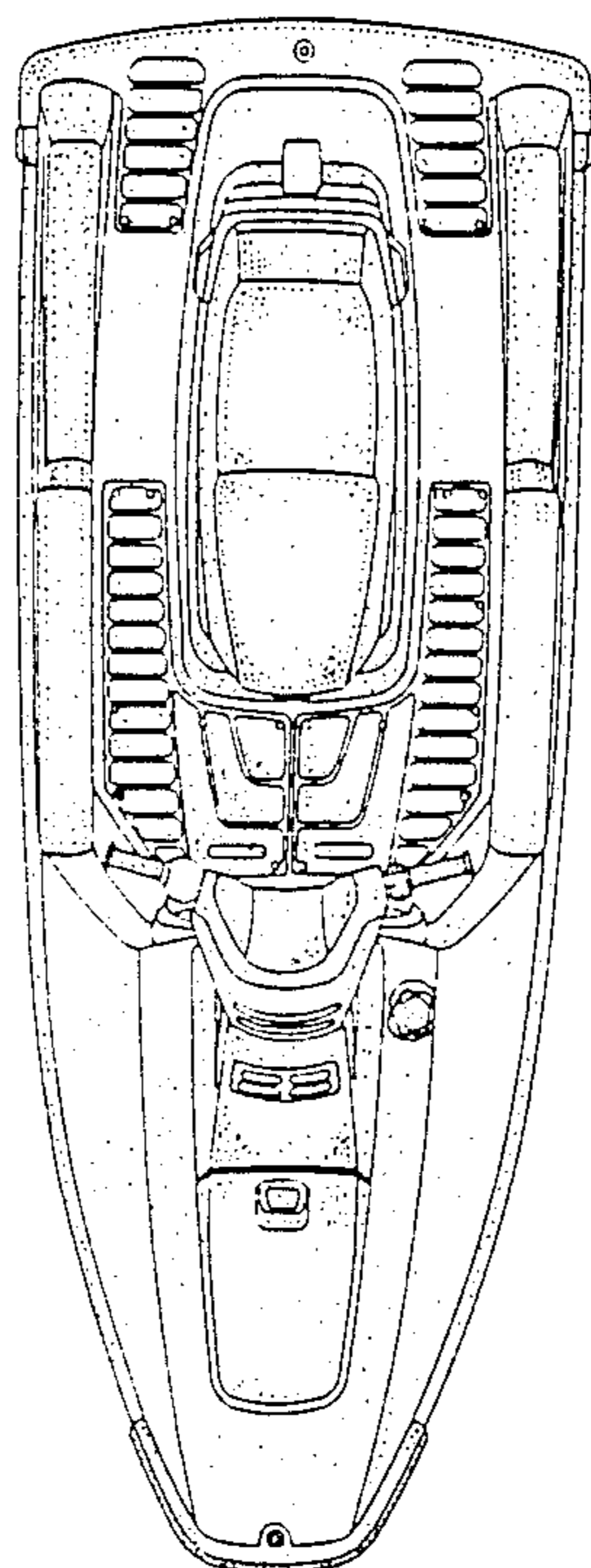

FIG. 4

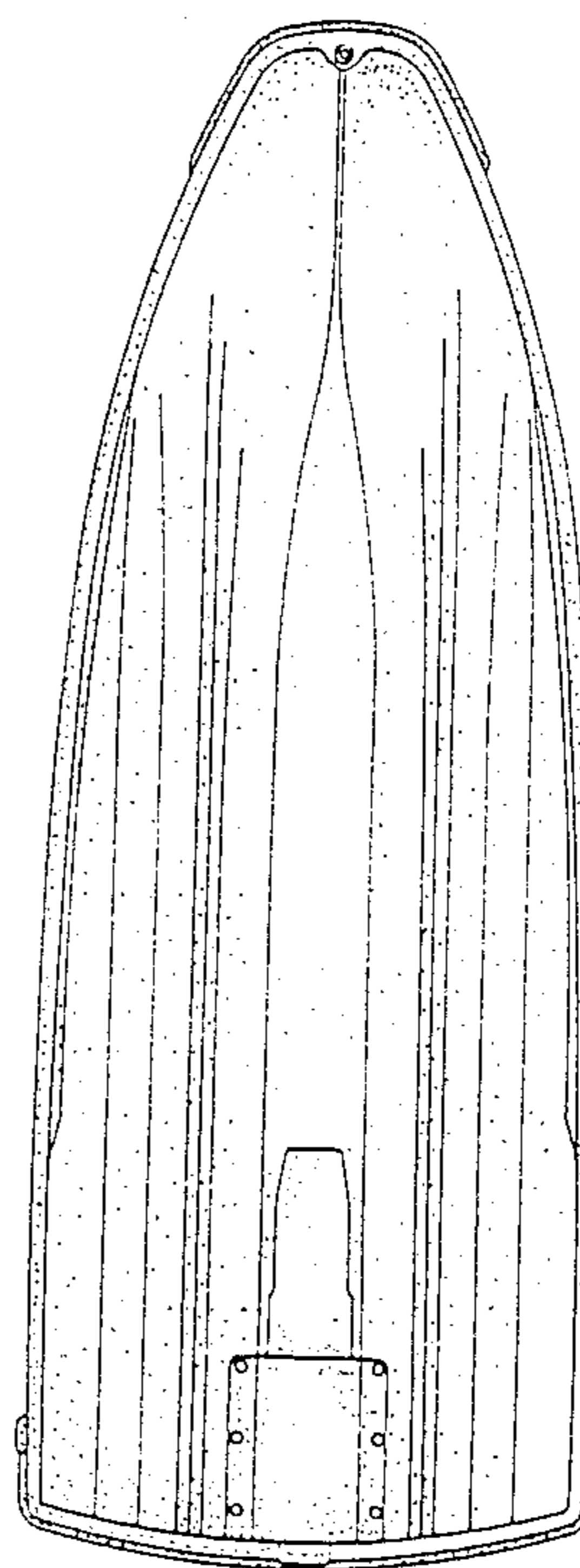

FIG. 5

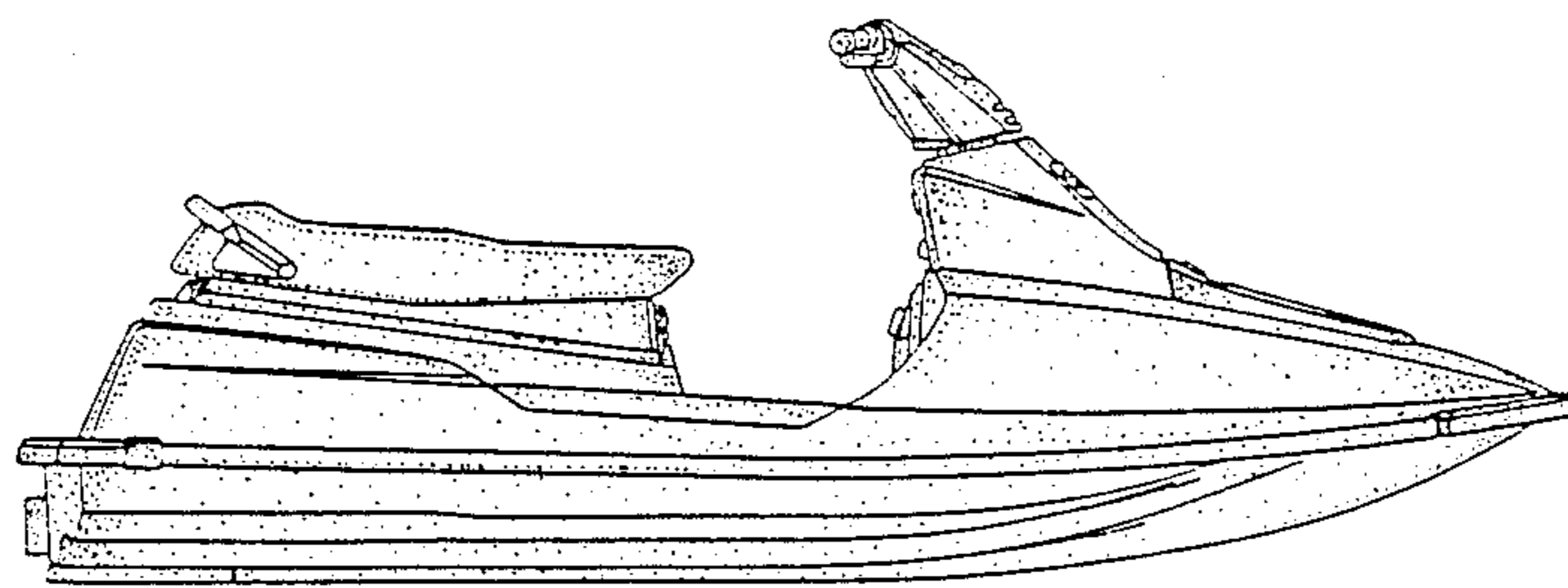

FIG. 6

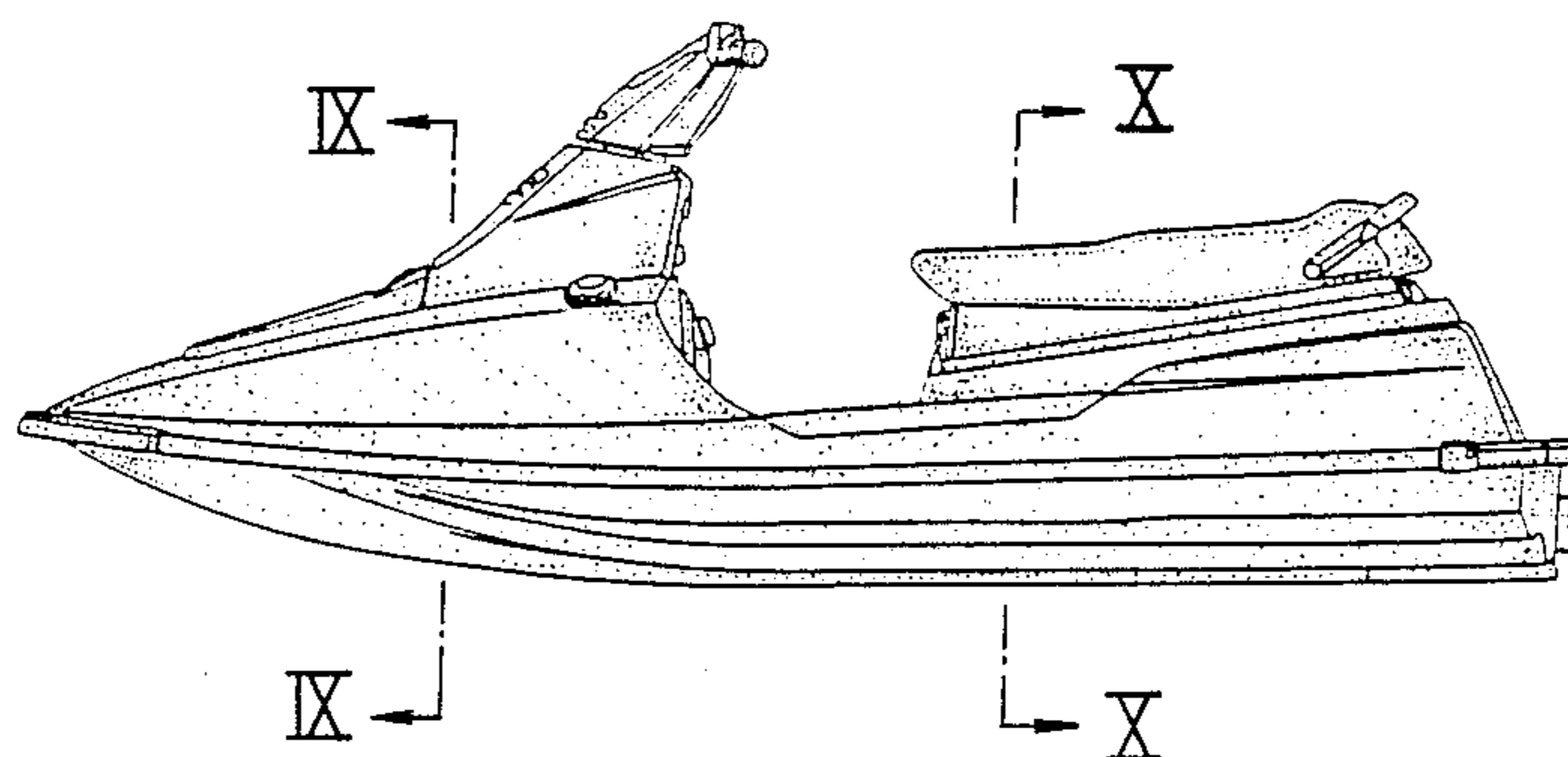

FIG. 7

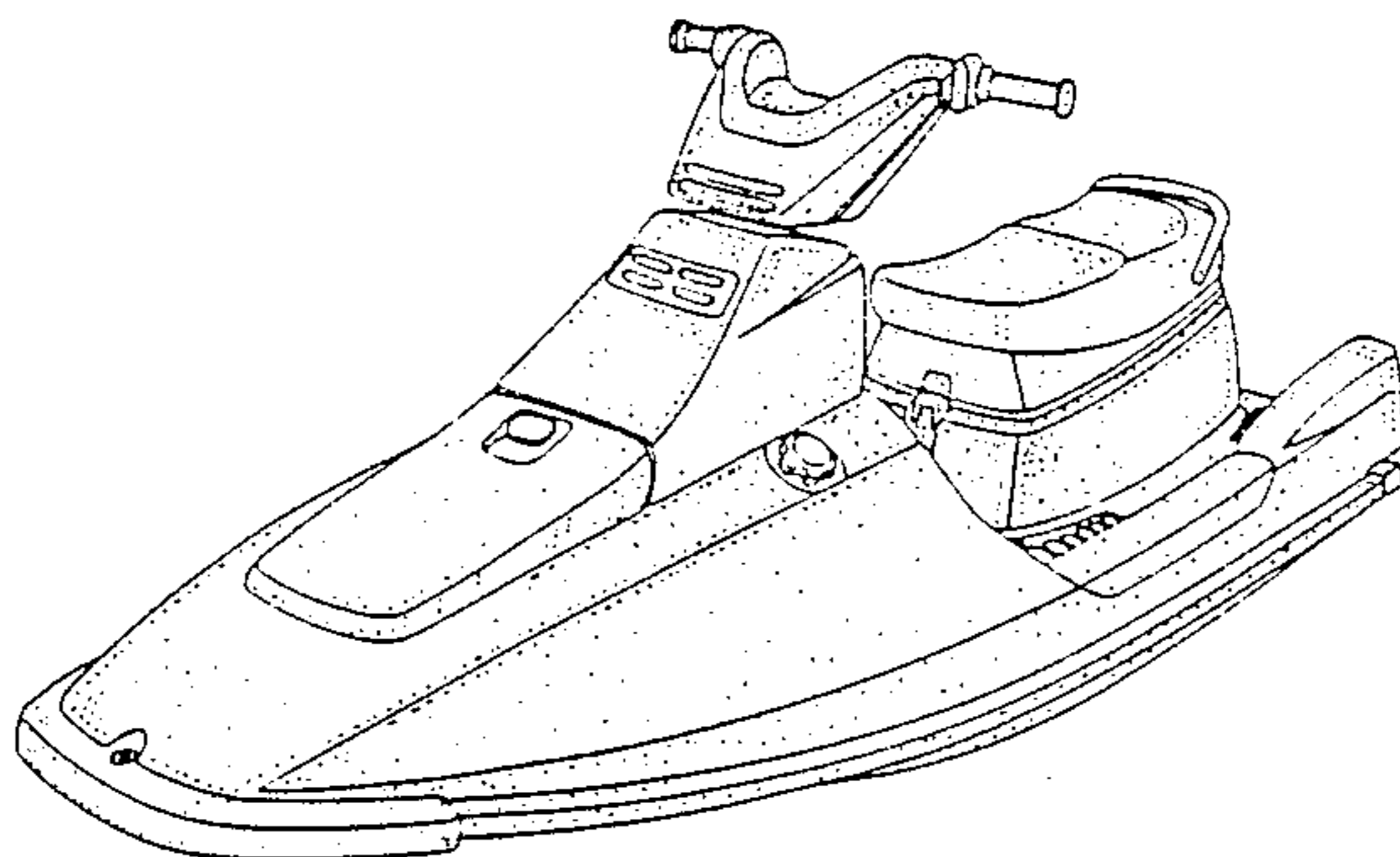

FIG. 8

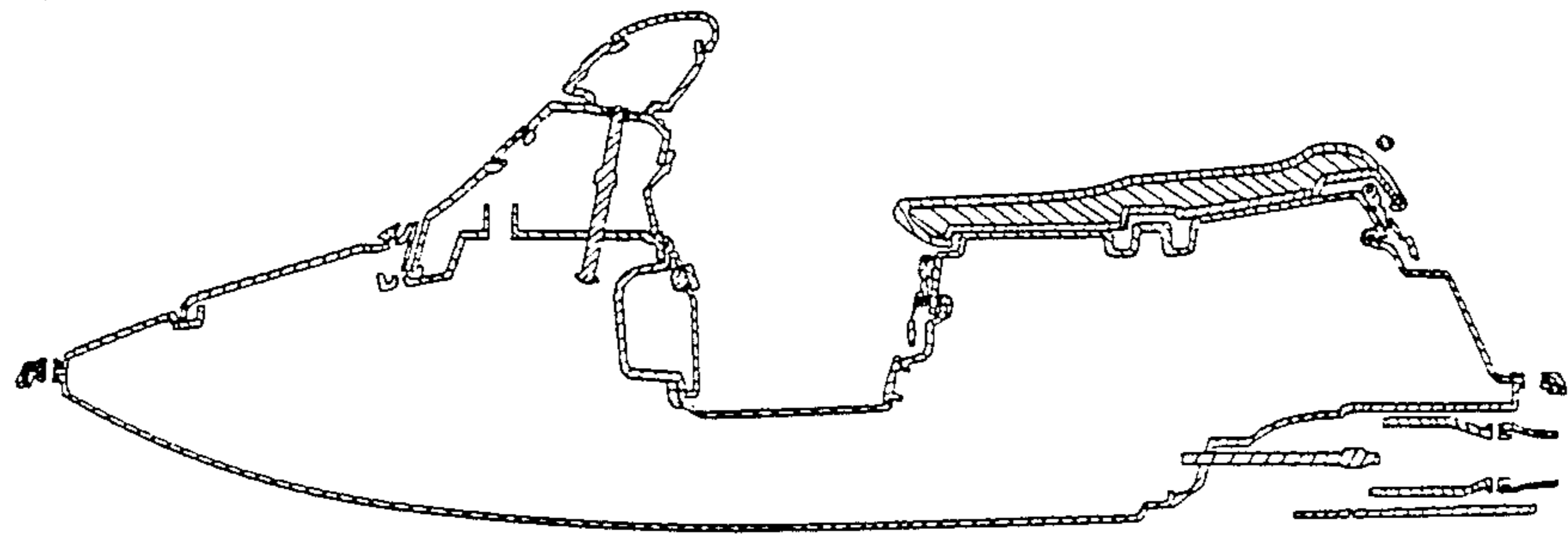

FIG. 9

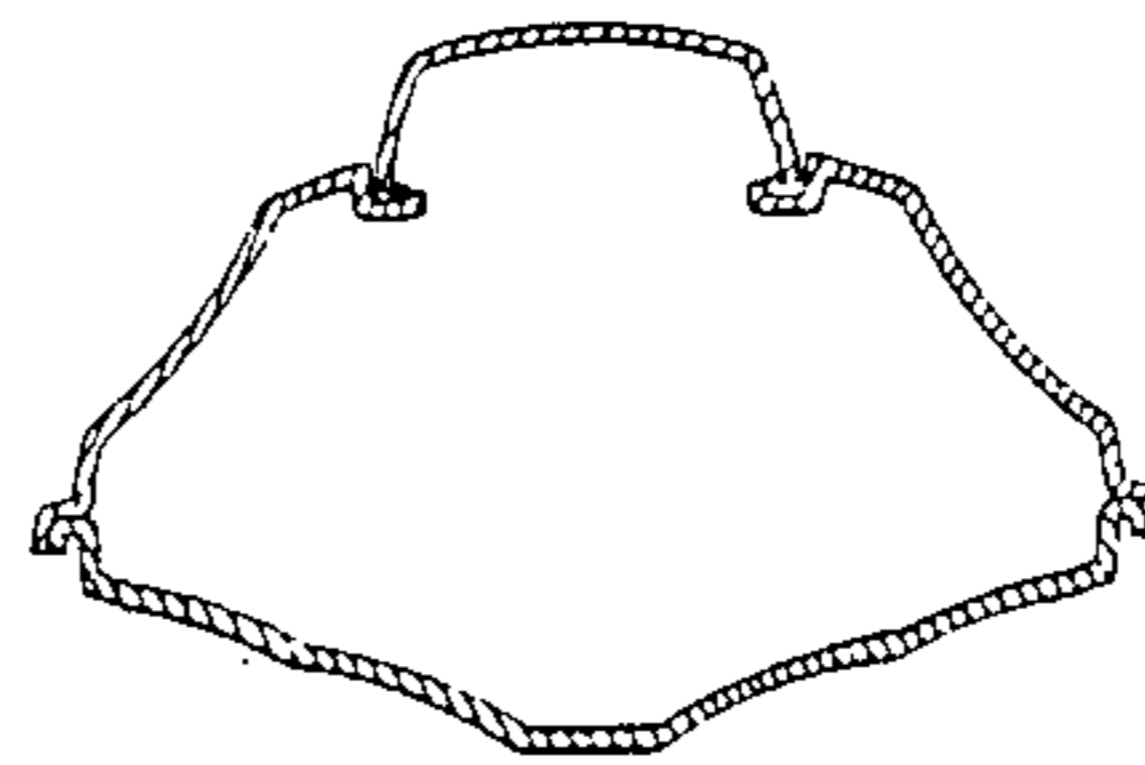

FIG. 10

