

[54] MOTORCYCLE

[75] Inventors: Mitsuyoshi Kohama; Shinichi Yamase; Hiroshi Takemori, all of Saitama, Japan

[73] Assignee: Honda Giken Kogyo Kabushiki Kaisha, Tokyo, Japan

[**] Term: 14 Years

[21] Appl. No.: 67,458

[22] Filed: Jun. 26, 1987

[30] Foreign Application Priority Data

Dec. 27, 1986 [JP] Japan 61-52002

[52] U.S. Cl. D12/110

[58] Field of Search D12/110; 180/219, 220

[56] References Cited

U.S. PATENT DOCUMENTS

D. 270,435 9/1983 Gevert D12/110

OTHER PUBLICATIONS

Cycle World, 12/86, p. 14, Gilera Dakota 350 Motorcycle.

Cycle World, 6/86, p. 85, Cagiva 650 Elefant Motorcycle.

Cycle World, 1/85, p. 39, Honda 750R Motorcycle.

Primary Examiner—James M. Gandy

Assistant Examiner—Melody Brown

Attorney, Agent, or Firm—Irving M. Weiner; Joseph P. Carrier; Pamela S. Burt

[57] CLAIM

The ornamental design for a motorcycle, as shown.

DESCRIPTION

FIG. 1 is a perspective view of a motorcycle showing our new design;

FIG. 2 is a right side elevational view thereof;

FIG. 3 is a left side elevational view thereof;

FIG. 4 is a front perspective view thereof;

FIG. 5 is a top plan view thereof; and

FIG. 6 is a rear perspective view thereof.

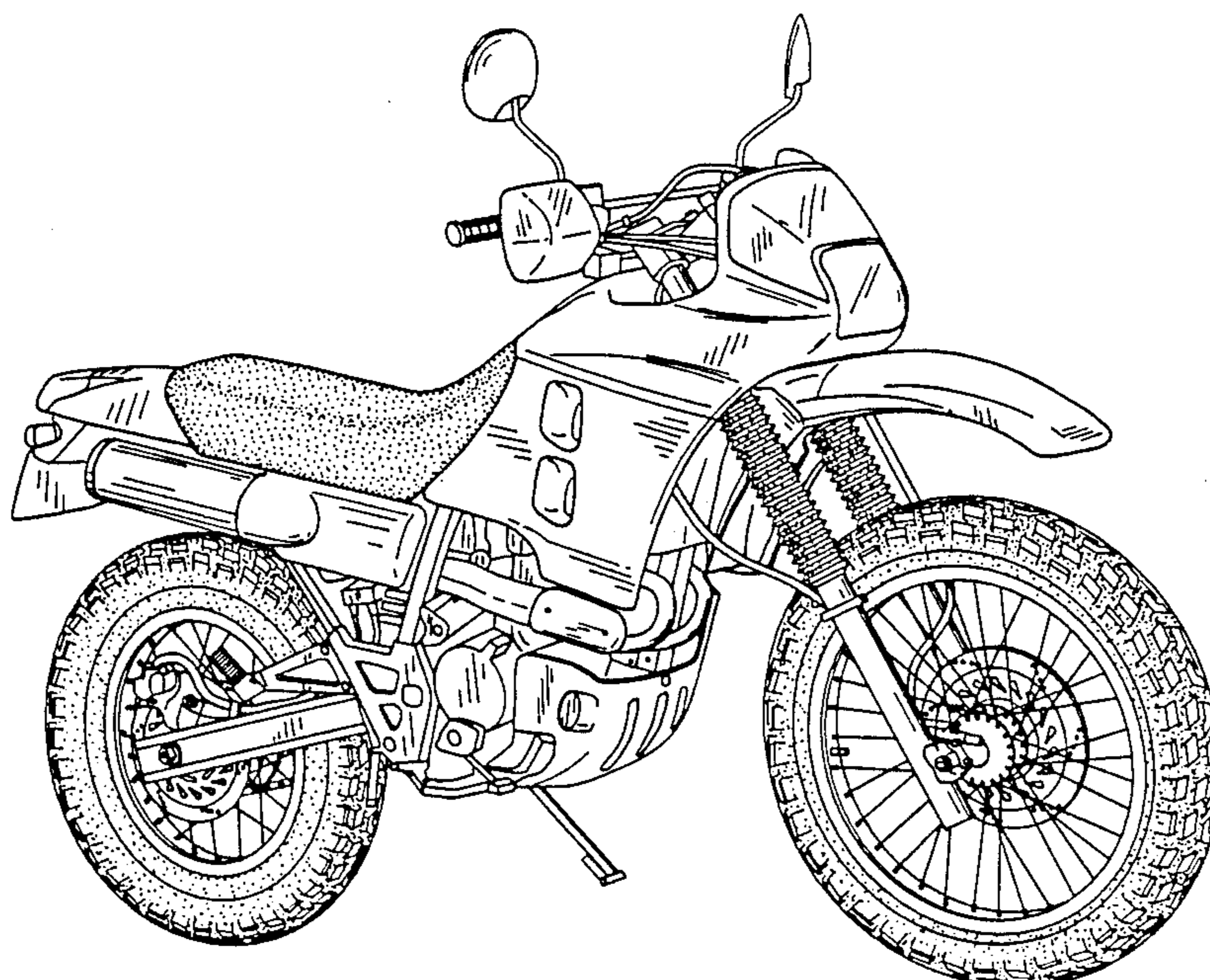

FIG. 1

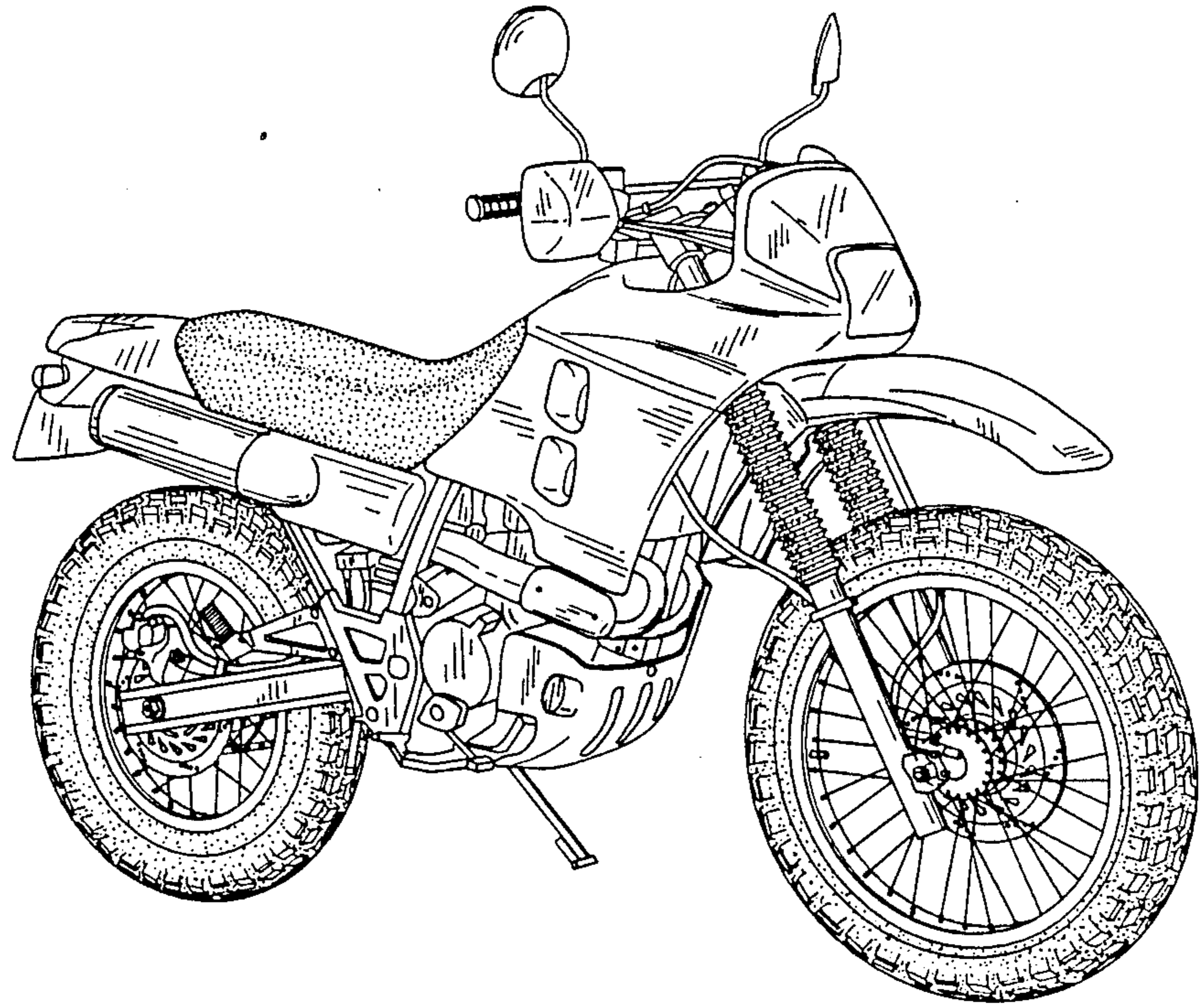

FIG. 2

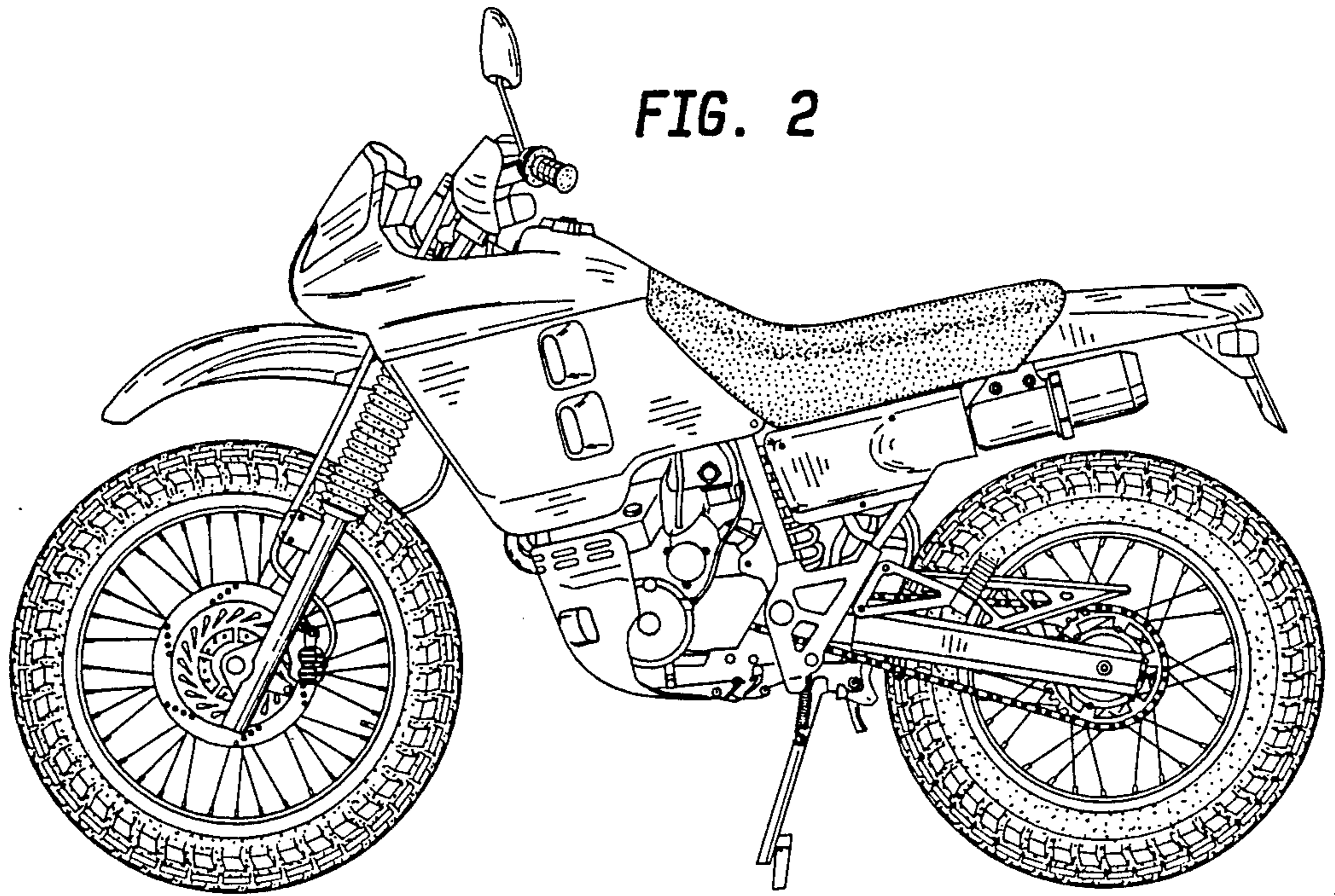

FIG. 3

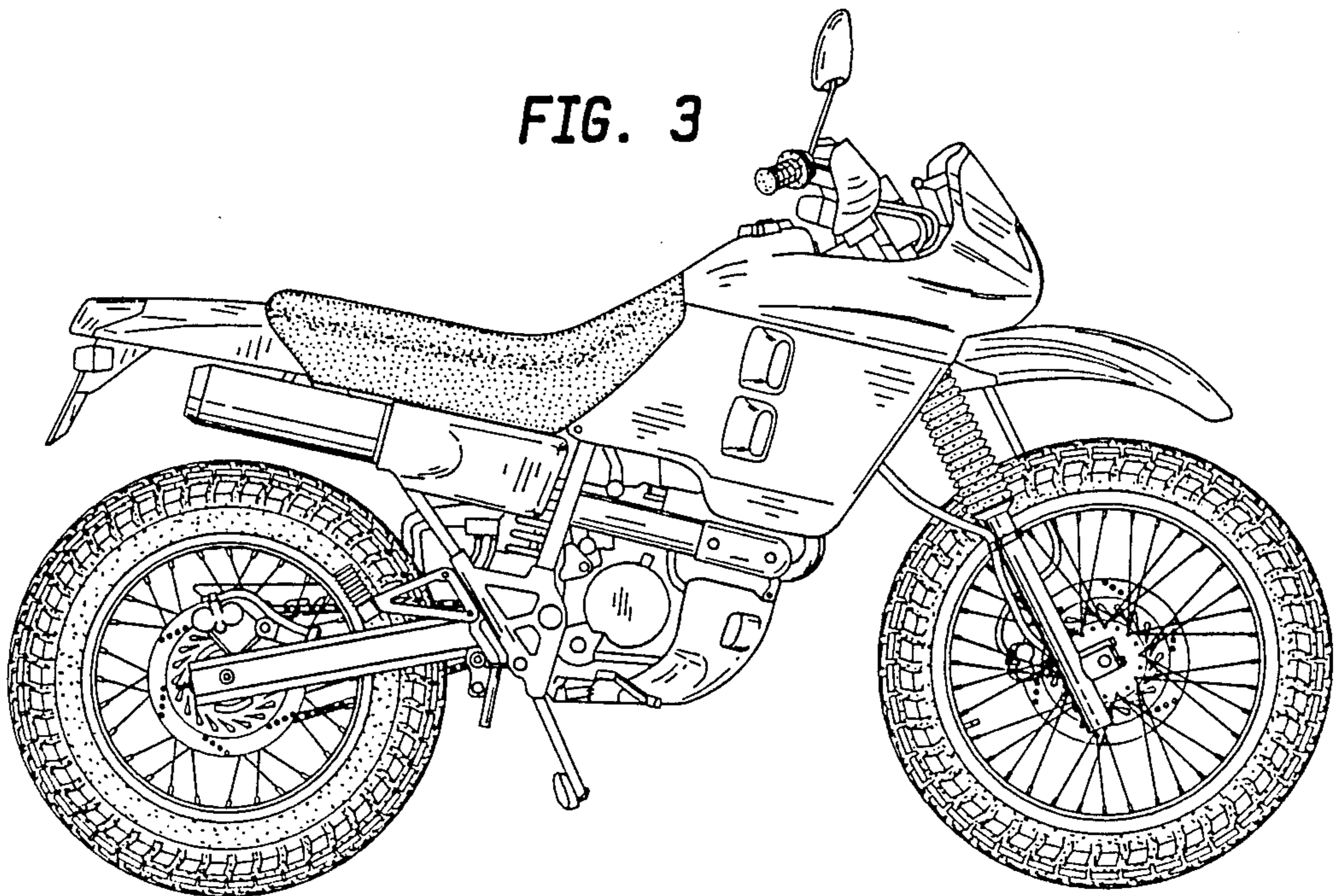

FIG. 4

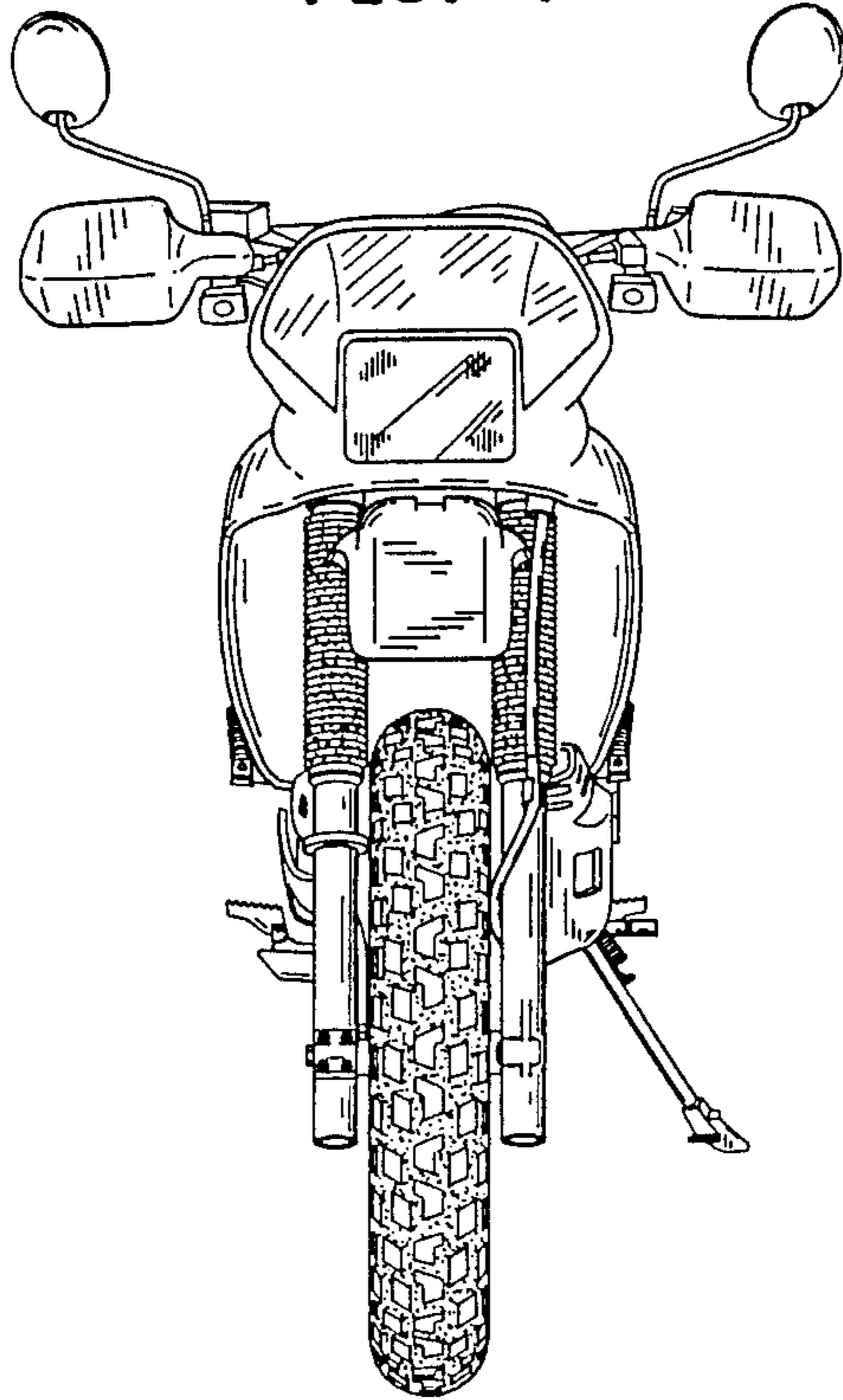

FIG. 5

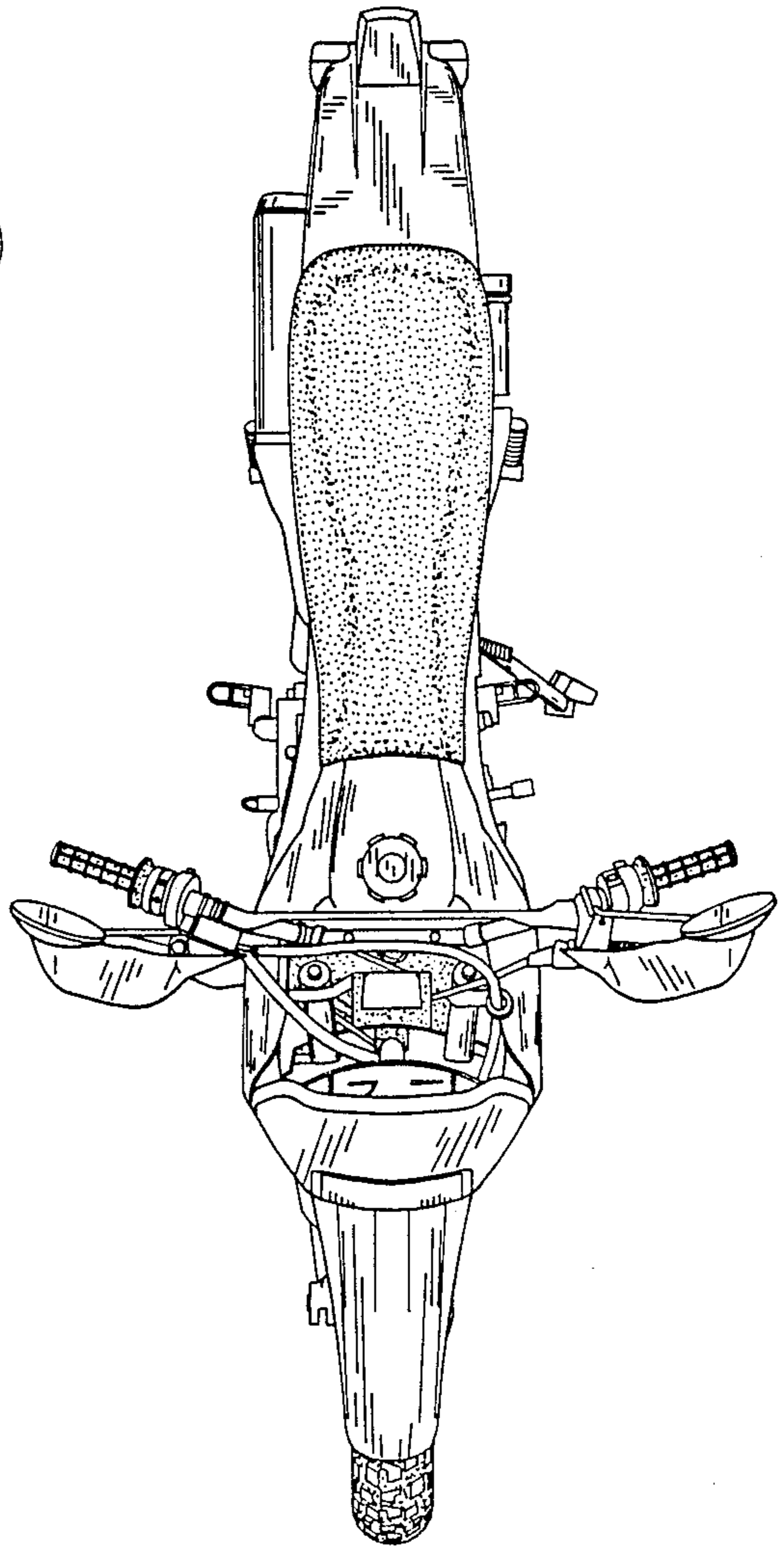

FIG. 6

