

[54] TAILGATE REINFORCEMENT

[76] Inventor: William T. Johnston, 3214 Laubert Rd., Randolph, Ohio 44268

[\*\*] Term: 14 Years

[21] Appl. No.: 231,170

[22] Filed: Aug. 11, 1988

[52] U.S. Cl. .... D12/15; D12/155; D25/125

[58] Field of Search ..... D12/155, 190, 15, 93, D12/98, 196; D25/119, 120, 121, 125; 296/188; 52/720, 721, 732; 220/1.5

[56] References Cited  
PUBLICATIONS

Anchor Extruded Plastics, p. 17, "h" Shaped Molding 5h-4, top center of page.

Anchor Extruded Plastics, p. 19, Architectural Molding 121AM-23, lower right side of page.

Primary Examiner—James M. Gandy  
Attorney, Agent, or Firm—Fay, Sharpe, Beall, Fagan, Minnich & McKee

[57] CLAIM

The ornamental design for a tailgate reinforcement, as shown and described.

DESCRIPTION

FIG. 1 is a perspective view of a tailgate reinforcement showing my new design;  
FIG. 2 is an enlarged left elevational view thereof;  
FIG. 3 is an enlarged front elevational view thereof;  
FIG. 4 is an enlarged top plan view thereof;  
FIG. 5 is an enlarged rear elevational view thereof; and,  
FIG. 6 is an enlarged bottom plan view thereof.  
The tailgate reinforcement has been broken away in the middle in FIGS. 1, 3, 4, 5 and 6 of the drawing to indicate indeterminate length.

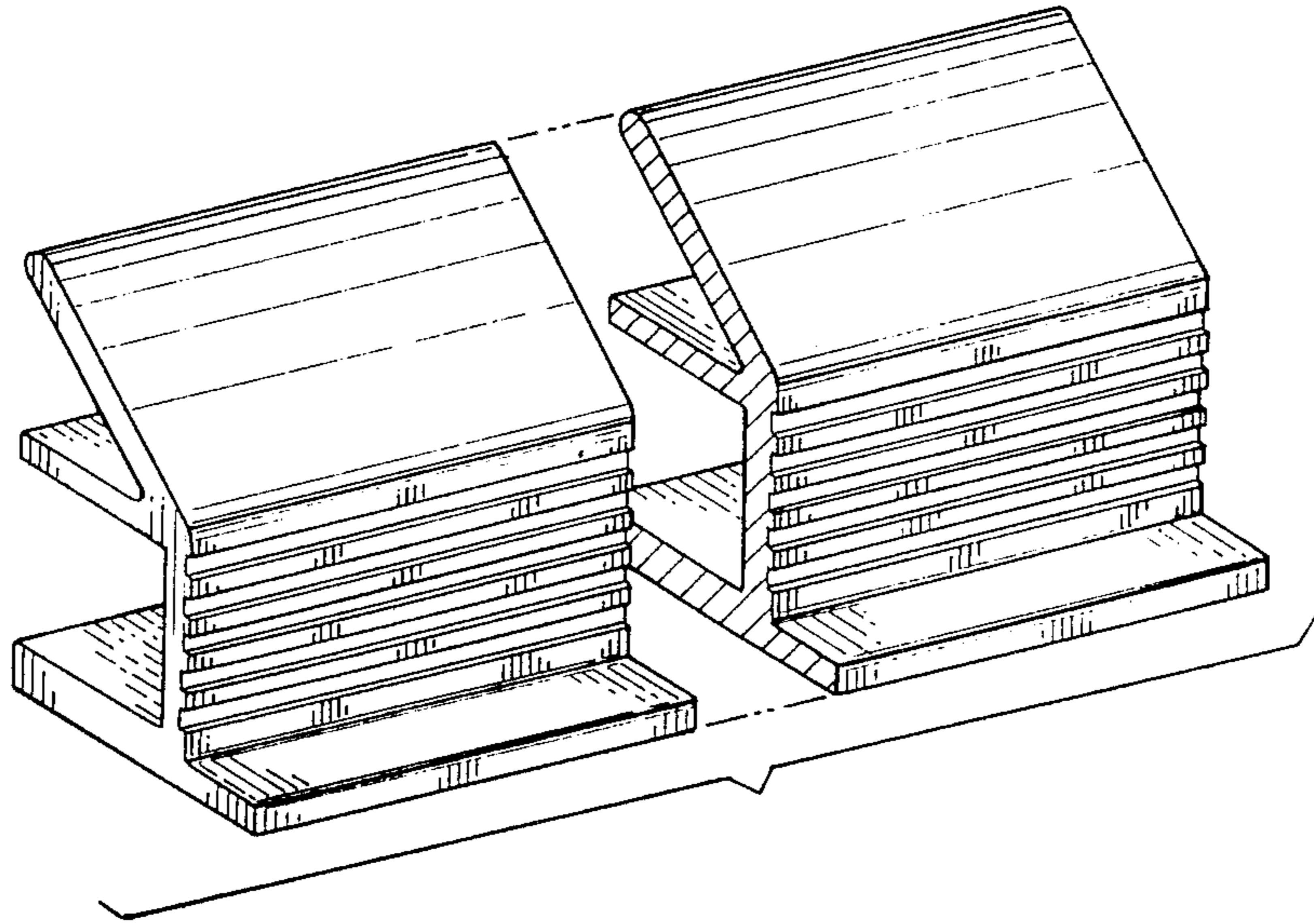

FIG. 1

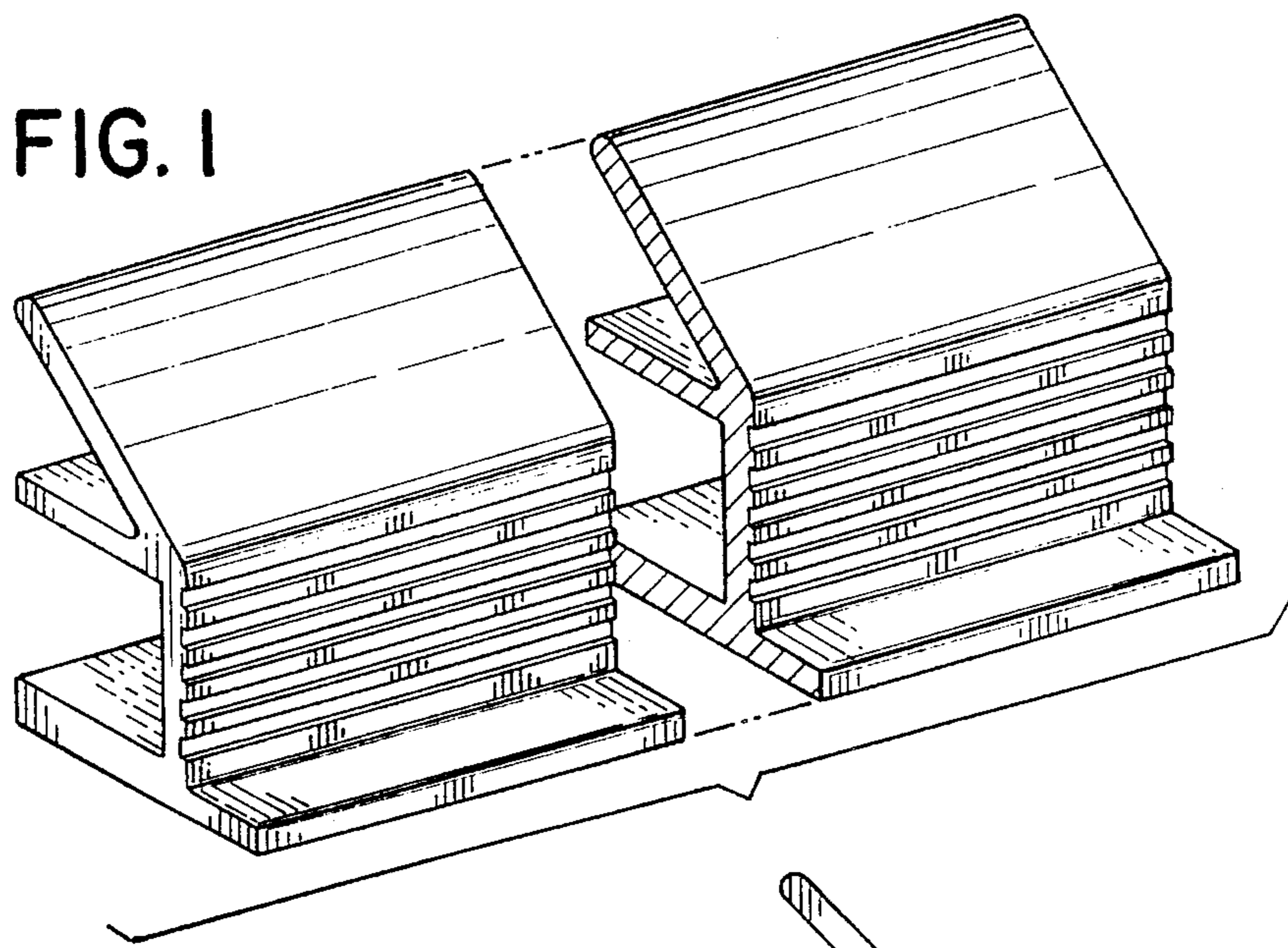

FIG. 2

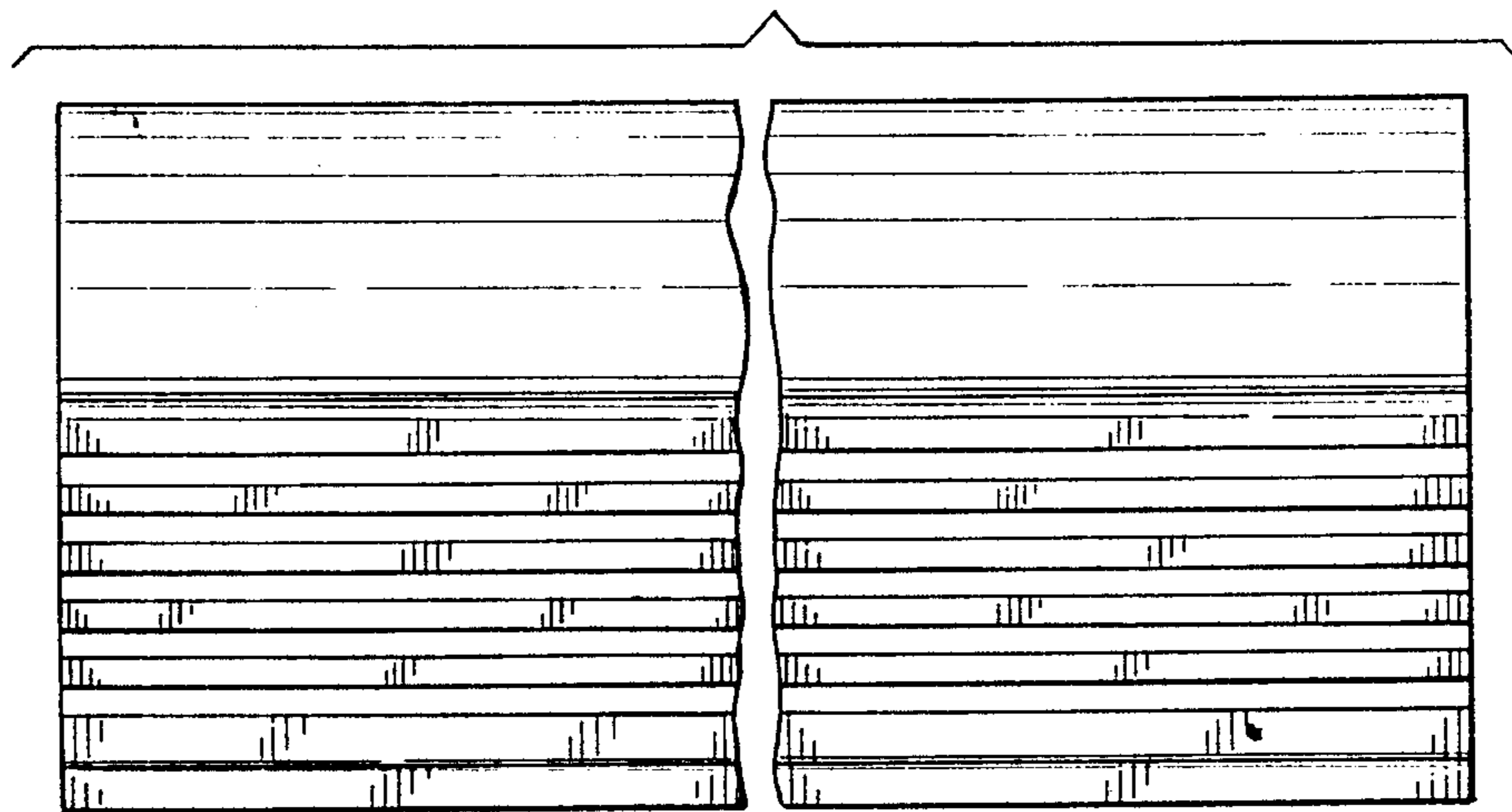
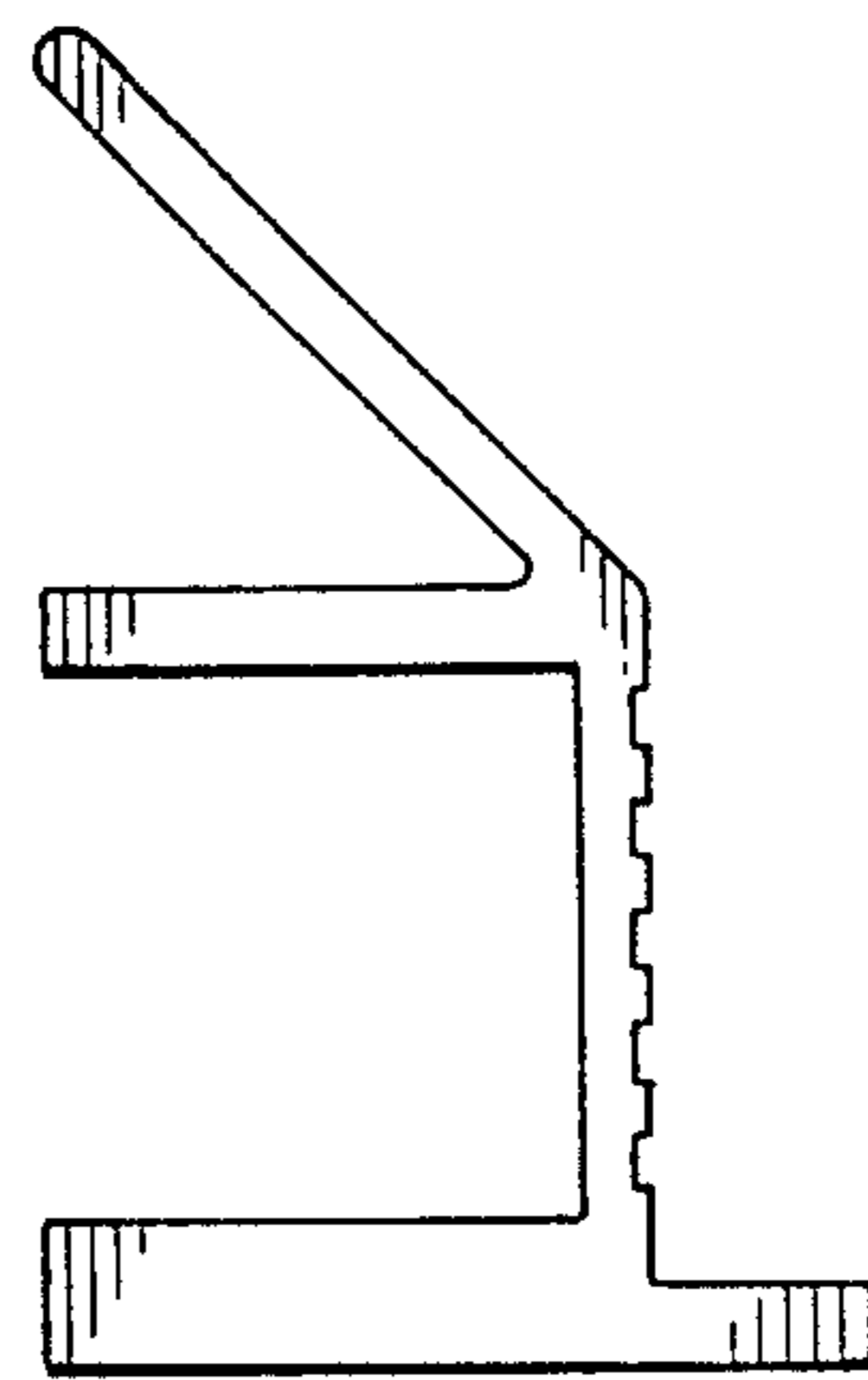

FIG. 3

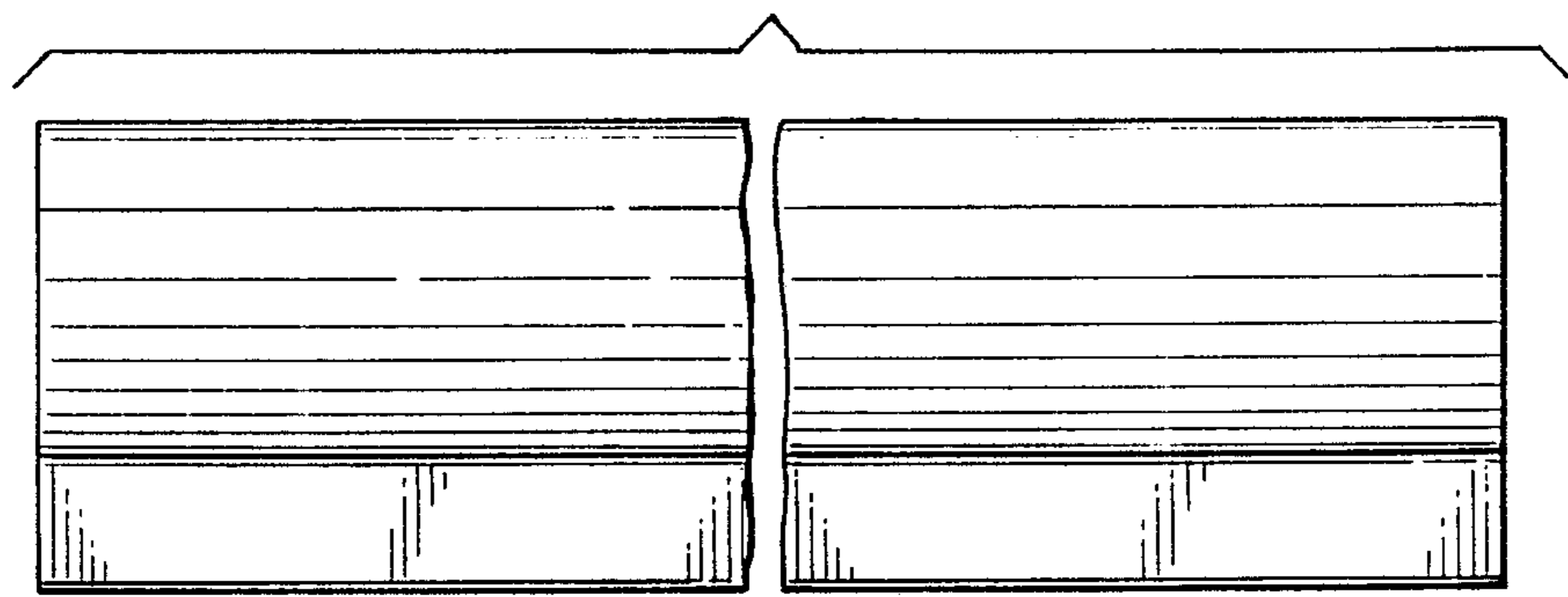

FIG. 4

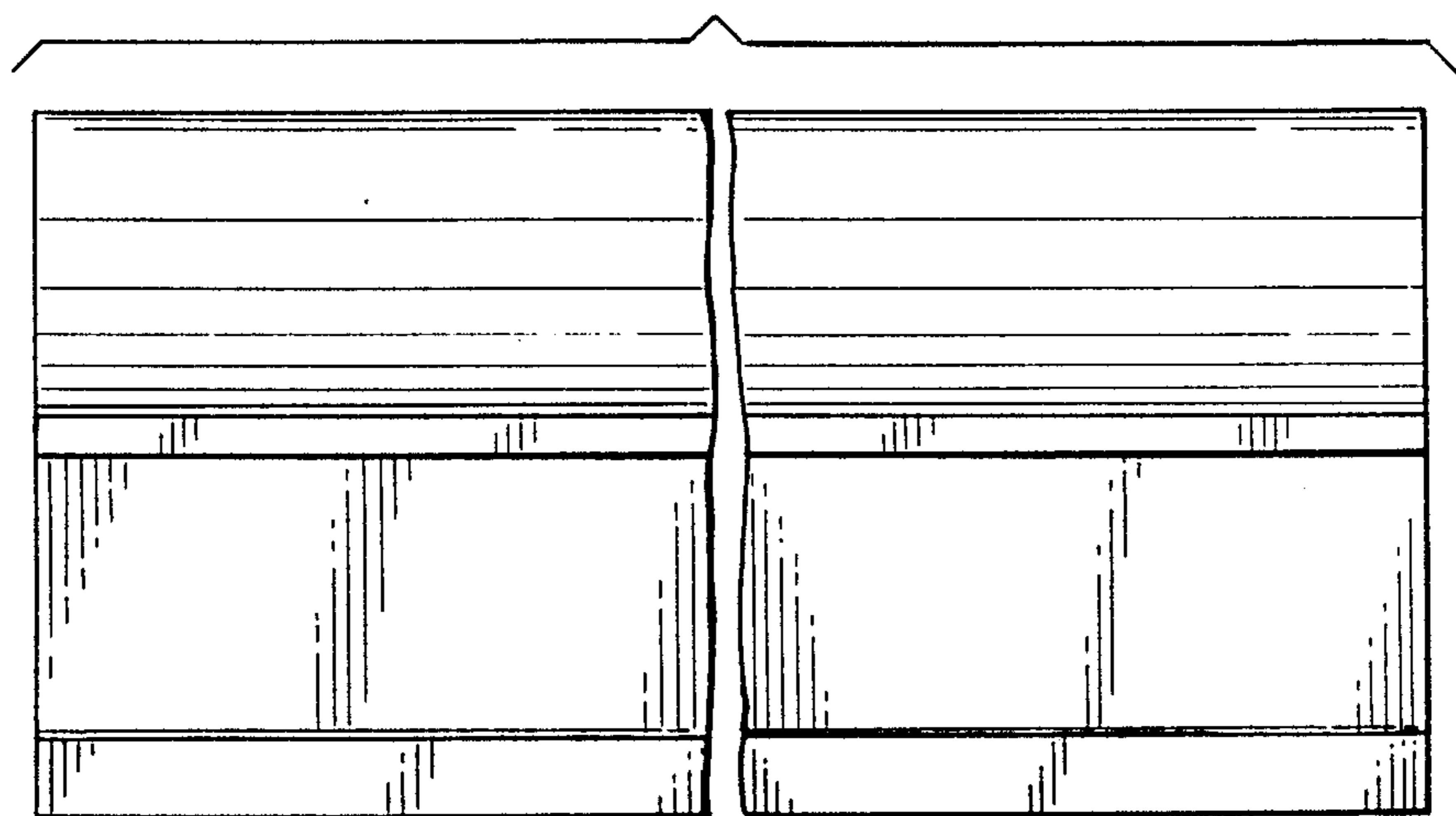

FIG. 5

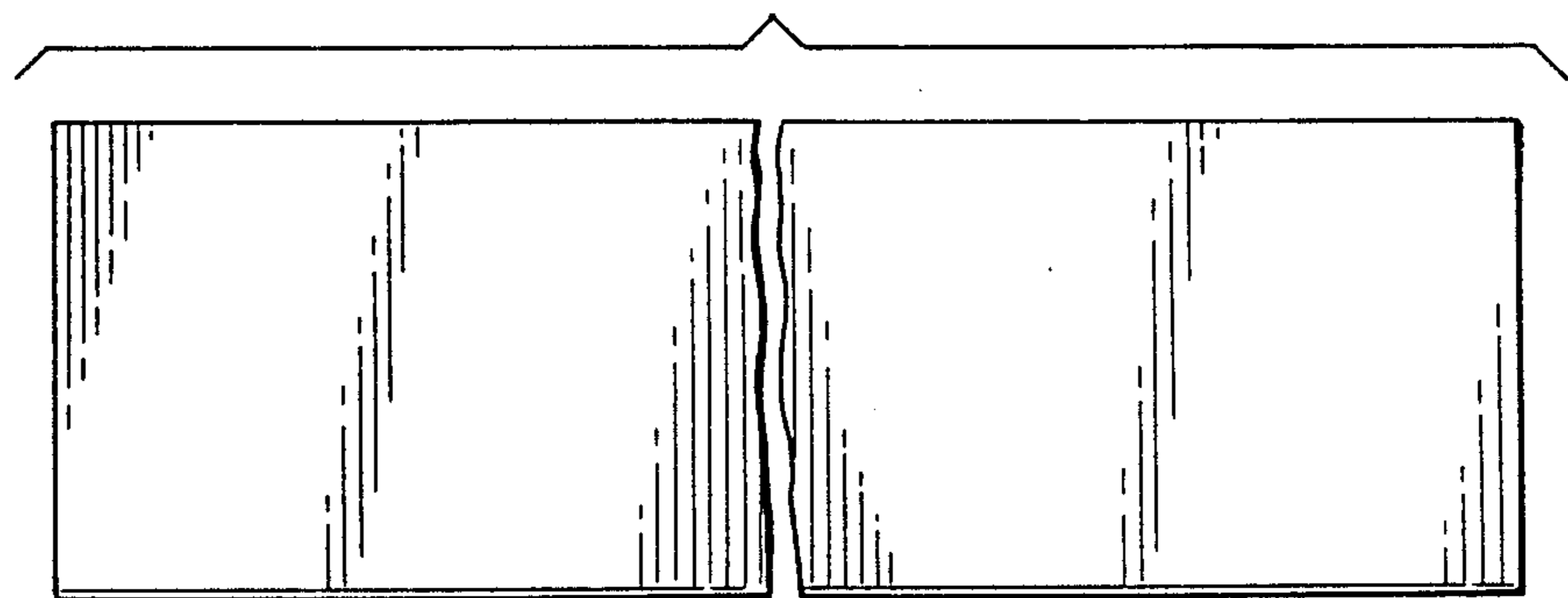

FIG. 6