

[54] **AUTOMOBILE RADIATOR GRILL**

[75] **Inventor: Hiroshi Yamamoto, Kanagawa, Japan**

[73] **Assignee: Mazda Motor Corporation, Hiroshima, Japan**

[**] **Term: 14 Years**

[21] **Appl. No.: 187,397**

[22] **Filed: Apr. 28, 1988**

[52] **U.S. Cl. D12/163**

[58] **Field of Search D12/163; 180/68.6**

[56] **References Cited**

U.S. PATENT DOCUMENTS

- D. 298,425 11/1988 Kubo D12/163
- D. 307,124 4/1990 Hayashi et al. D12/163

OTHER PUBLICATIONS

Motor Trend, 5/87, p. 105, Front Grill of Acura Legend Coupe, bottom of page.

Motor Trend, 11/87, p. 118, Front Grill of Mazda 626 Turbo 4WS, bottom of page.

Primary Examiner—James M. Gandy

Attorney, Agent, or Firm—Fleit, Jacobson, Cohn, Price, Holman & Stern

[57] **CLAIM**

The ornamental design for an automobile radiator grill, as shown.

DESCRIPTION

FIG. 1 is a front perspective view of the automobile radiator grill embodying my ornamental design;

FIG. 2 is a front elevational view thereof;

FIG. 3 is a right side elevational view thereof;

FIG. 4 is a left side elevational view thereof;

FIG. 5 is a top plan view thereof;

FIG. 6 is a bottom plan view thereof; and

FIG. 7 is a rear elevational view thereof.

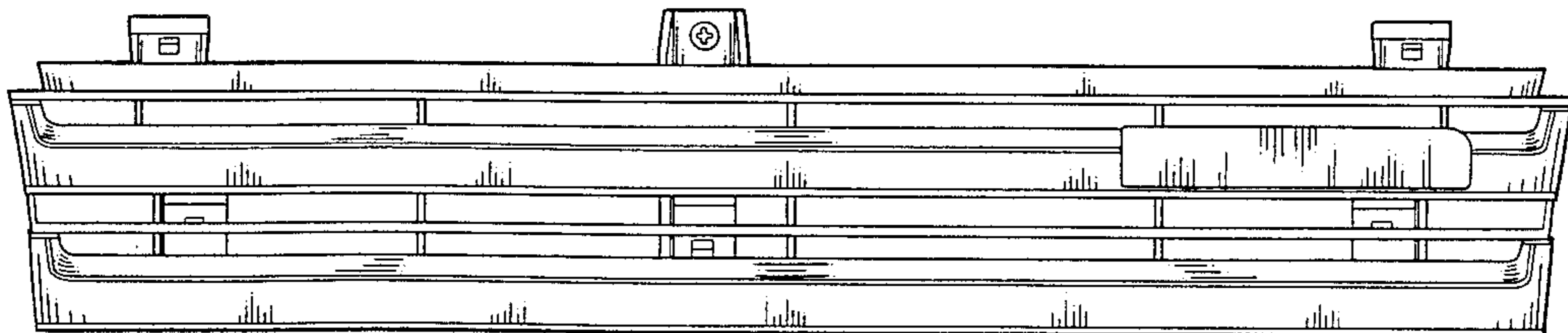

FIG. 1

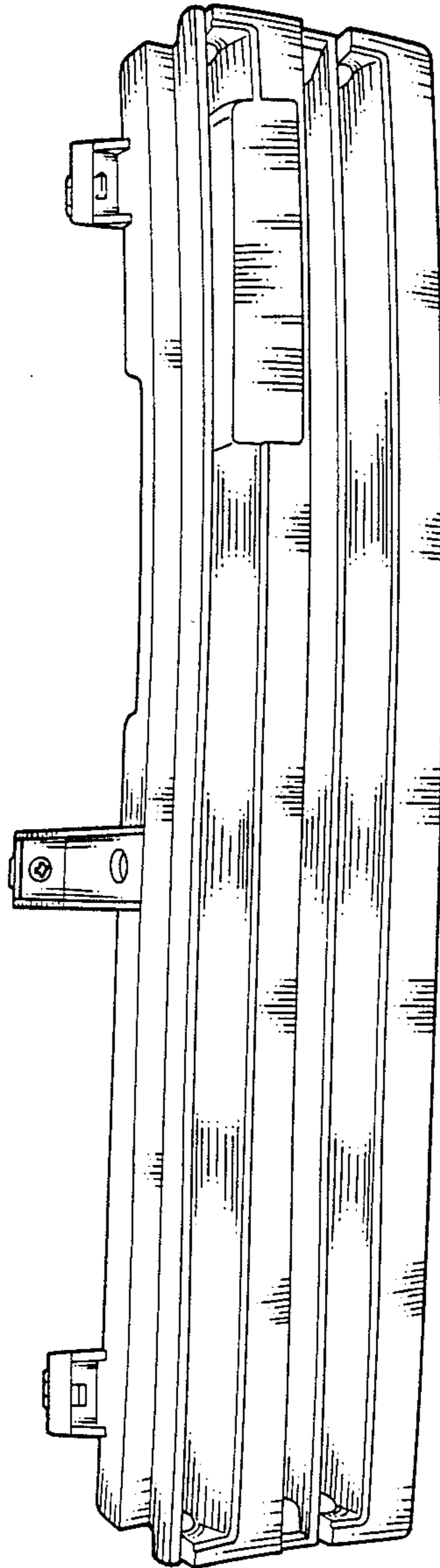

FIG. 2

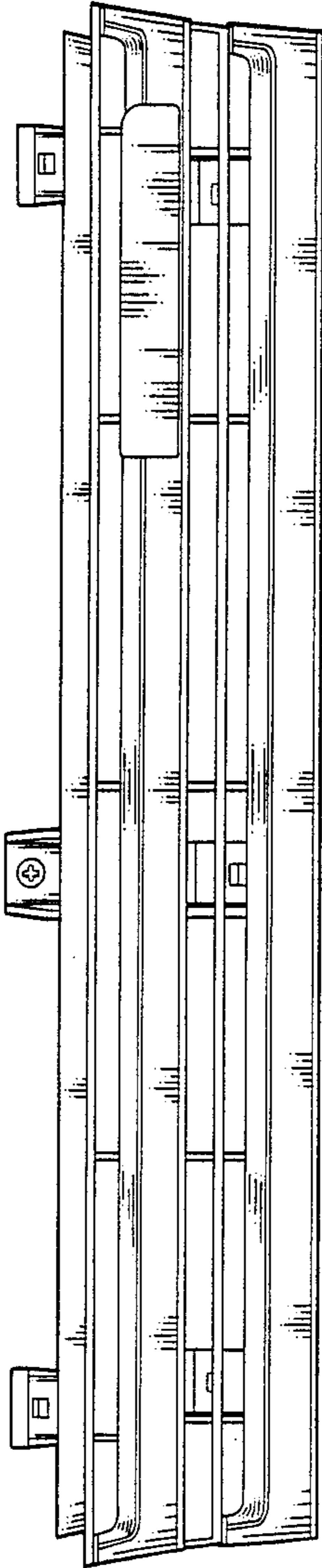

FIG. 4

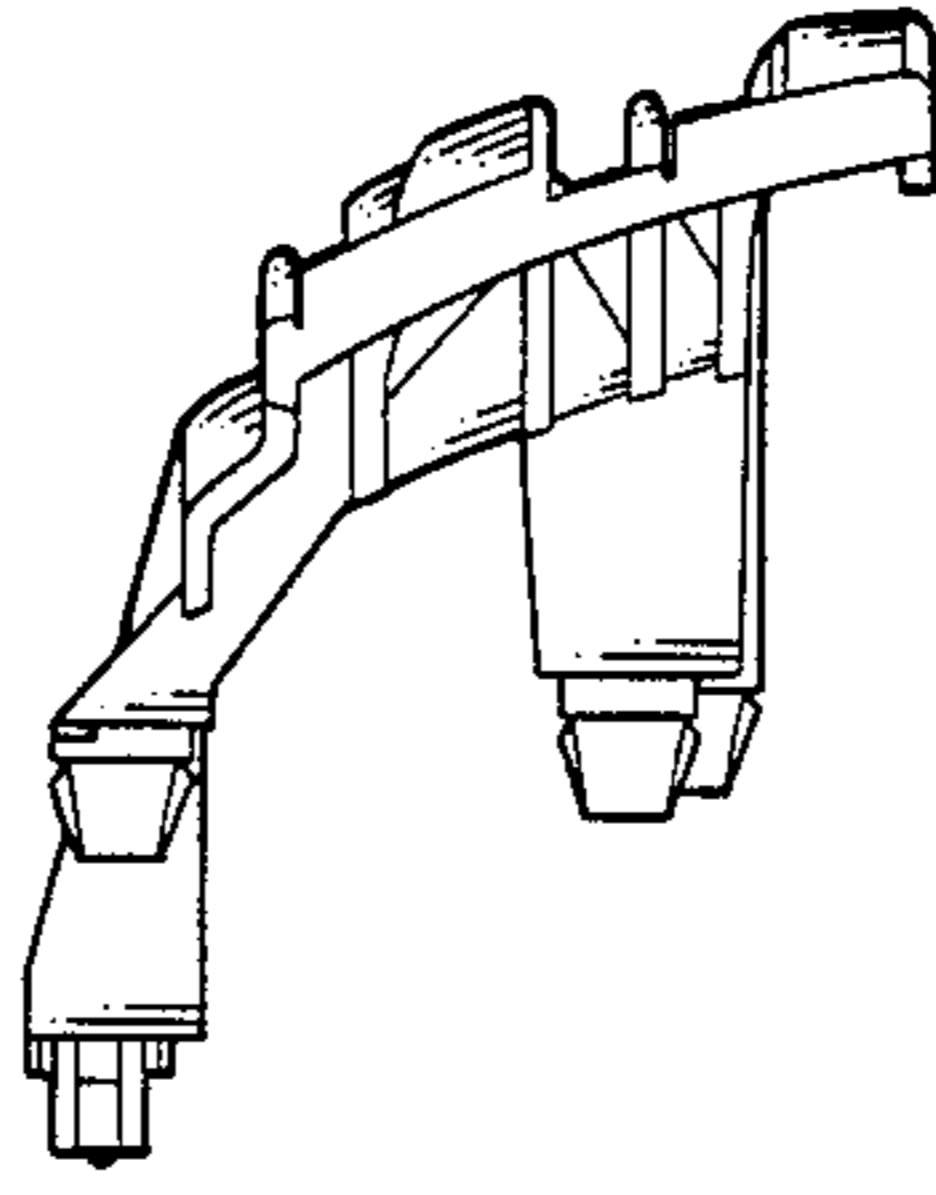

FIG. 3

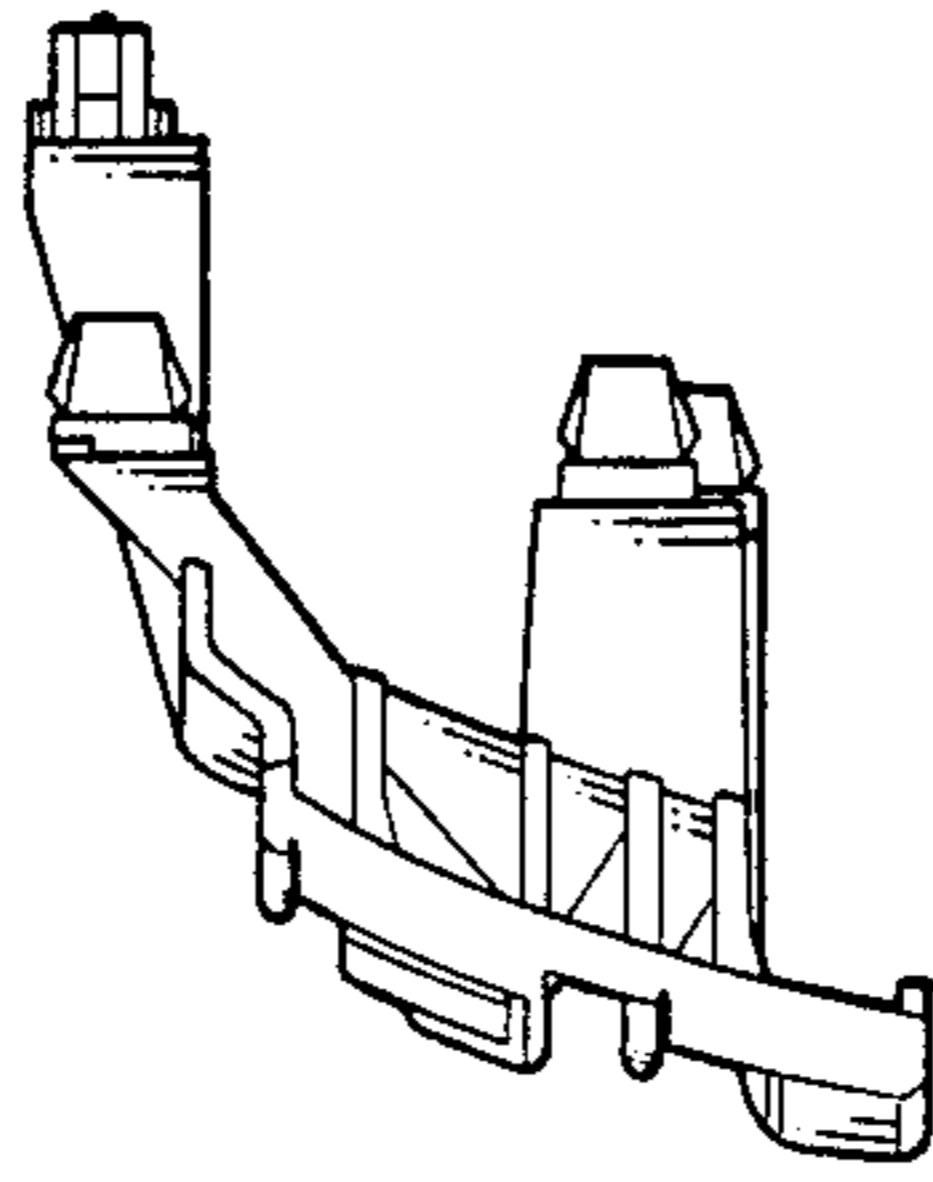

FIG. 5

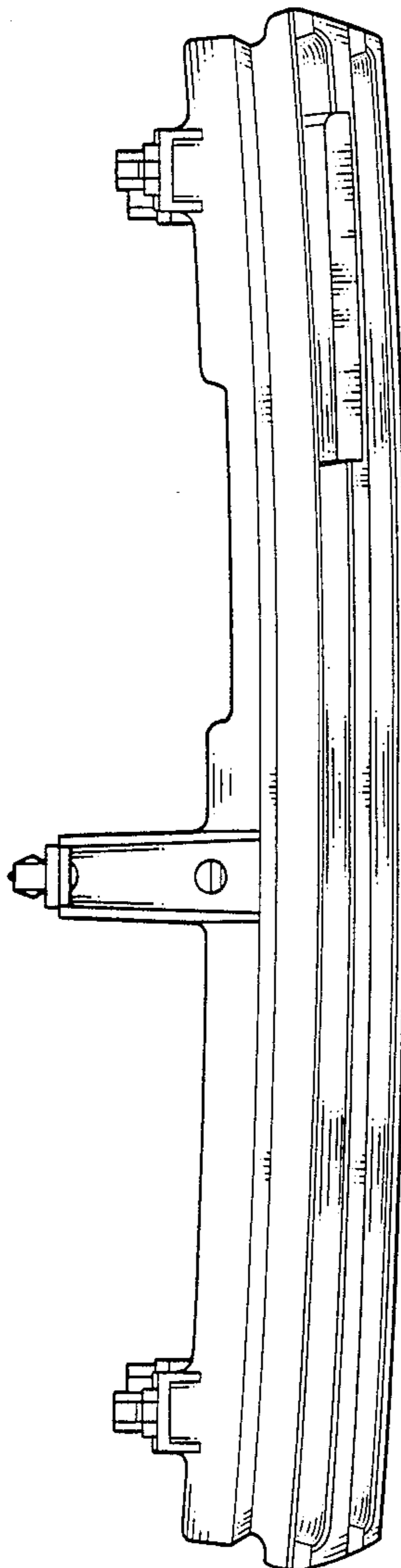

FIG. 6

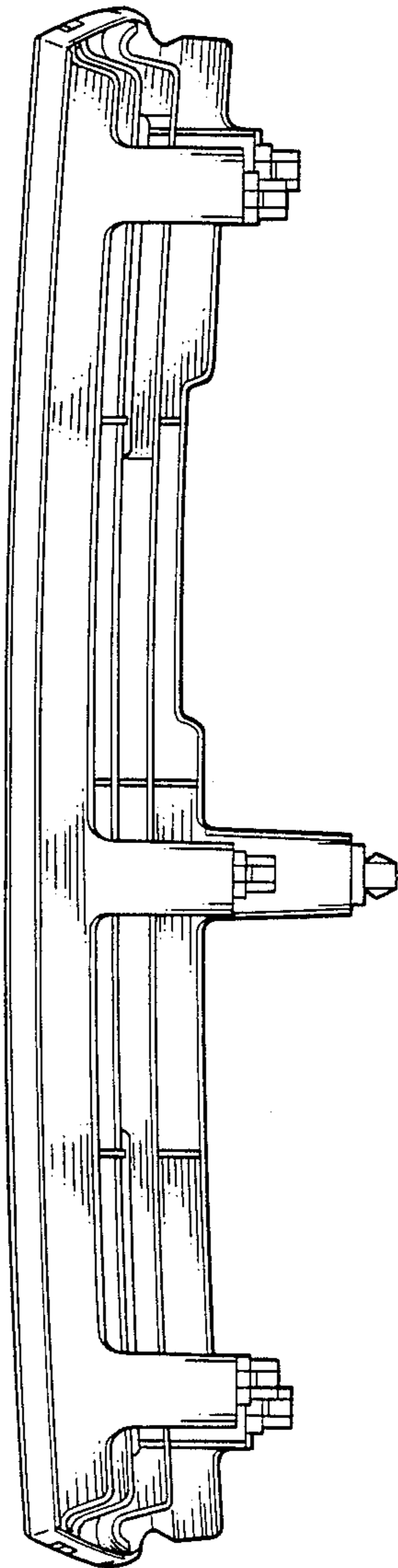

FIG. 7

