

[54] PEDAL BOAT

[76] Inventor: Paul A. Down, 8815 S. Bluff View,
Berrien Springs, Mich. 49103

[**] Term: 14 Years

[21] Appl. No.: 149,681

[22] Filed: Jan. 28, 1988

[52] U.S. Cl. D12/306; D12/310

[58] Field of Search D12/300, 309, 306;
440/29, 30, 27, 26, 90; 114/61, 57, 283

[56] References Cited

U.S. PATENT DOCUMENTS

D. 221,809	9/1971	Love	D12/306
2,685,270	8/1954	Pieraccioni Dr Pierac	440/29
3,185,125	5/1965	Haman	440/27
3,257,987	6/1966	Liard	D12/306
4,493,658	1/1985	Hildebrand	440/30
4,668,196	5/1987	Billmayer et al.	440/26

FOREIGN PATENT DOCUMENTS

463803 6/1951 Italy 440/26

Primary Examiner—Wallace R. Burke
Assistant Examiner—Kay H. Chin
Attorney, Agent, or Firm—James D. Hall

[57] CLAIM

The ornamental design for a pedal boat, as shown and described.

DESCRIPTION

FIG. 1 is a top perspective view of a pedal boat showing my new design;
FIG. 2 is a right side elevational view thereof, the left side elevational view being a mirror image of that shown;
FIG. 3 is a top plan view thereof;
FIG. 4 is a bottom plan view thereof;
FIG. 5 is a front elevational view thereof; and
FIG. 6 is a rear elevational view thereof.

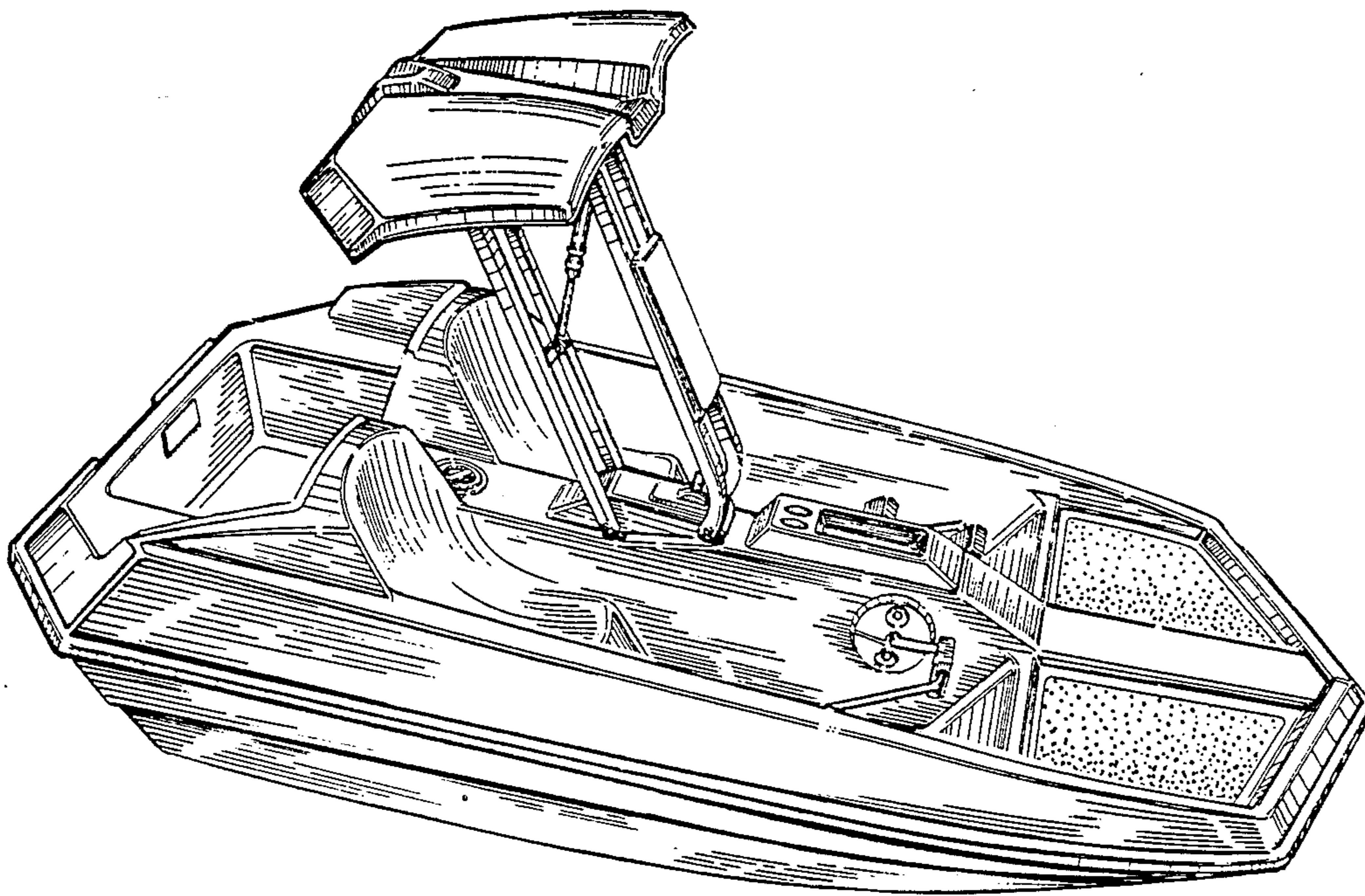

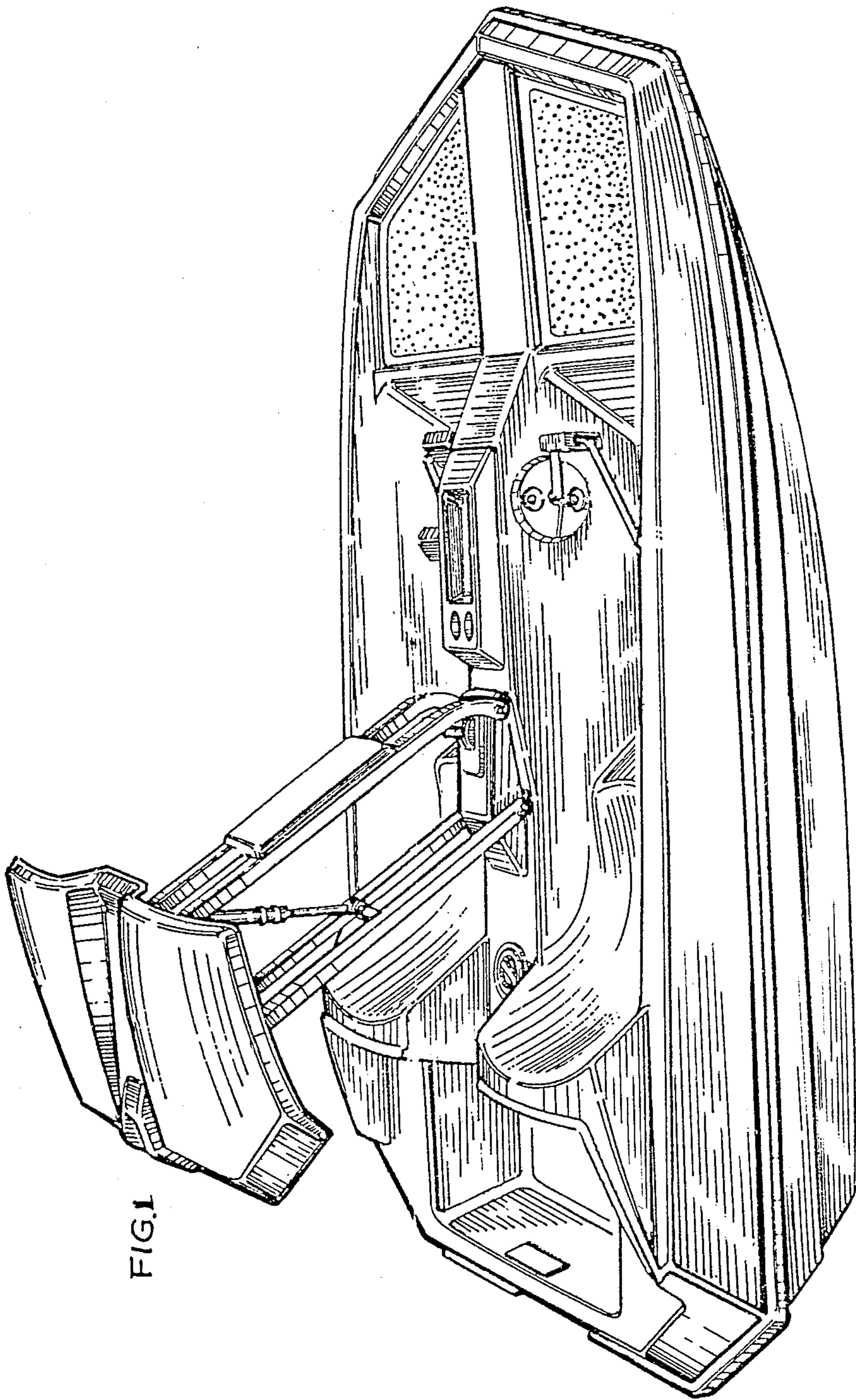

FIG. 1

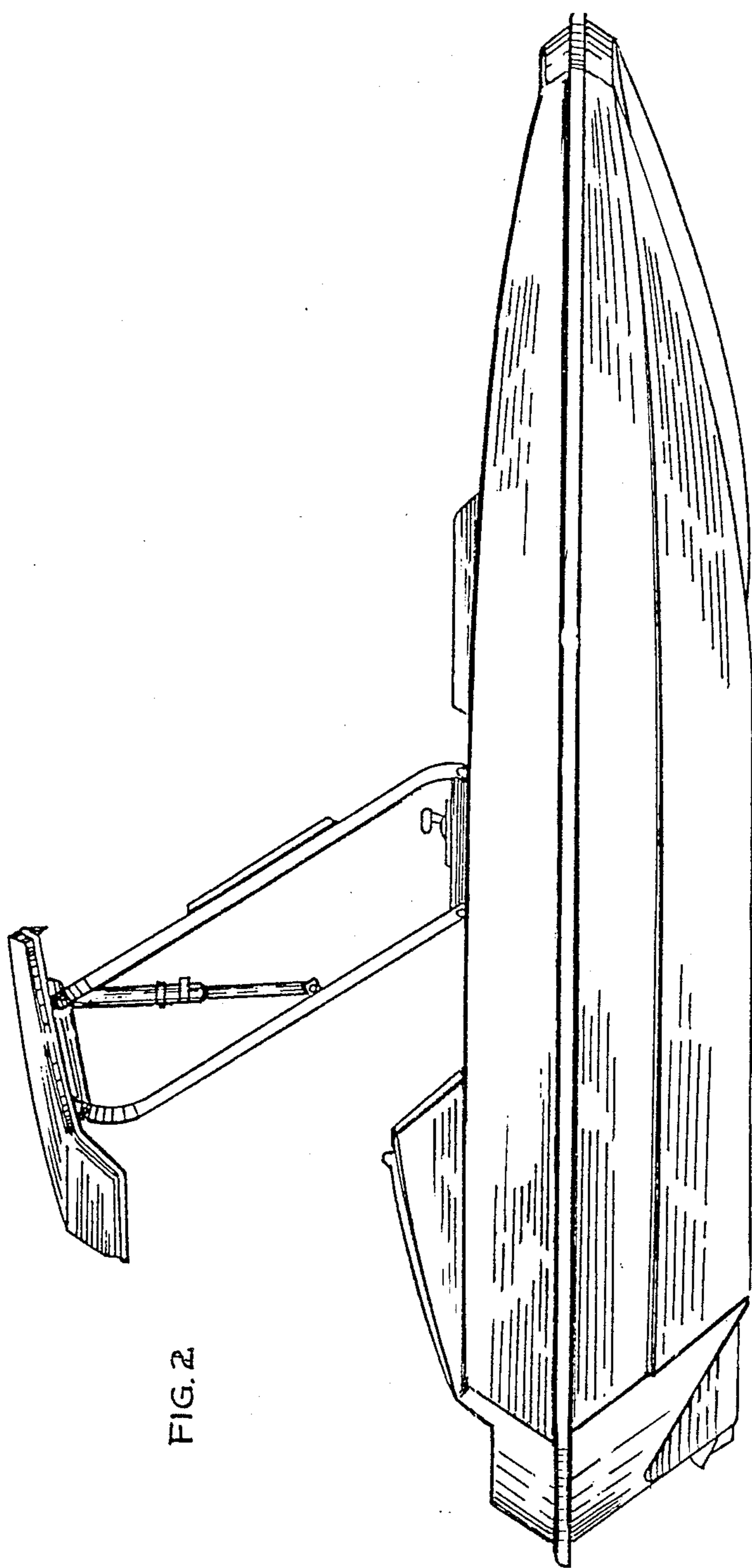

FIG. 2

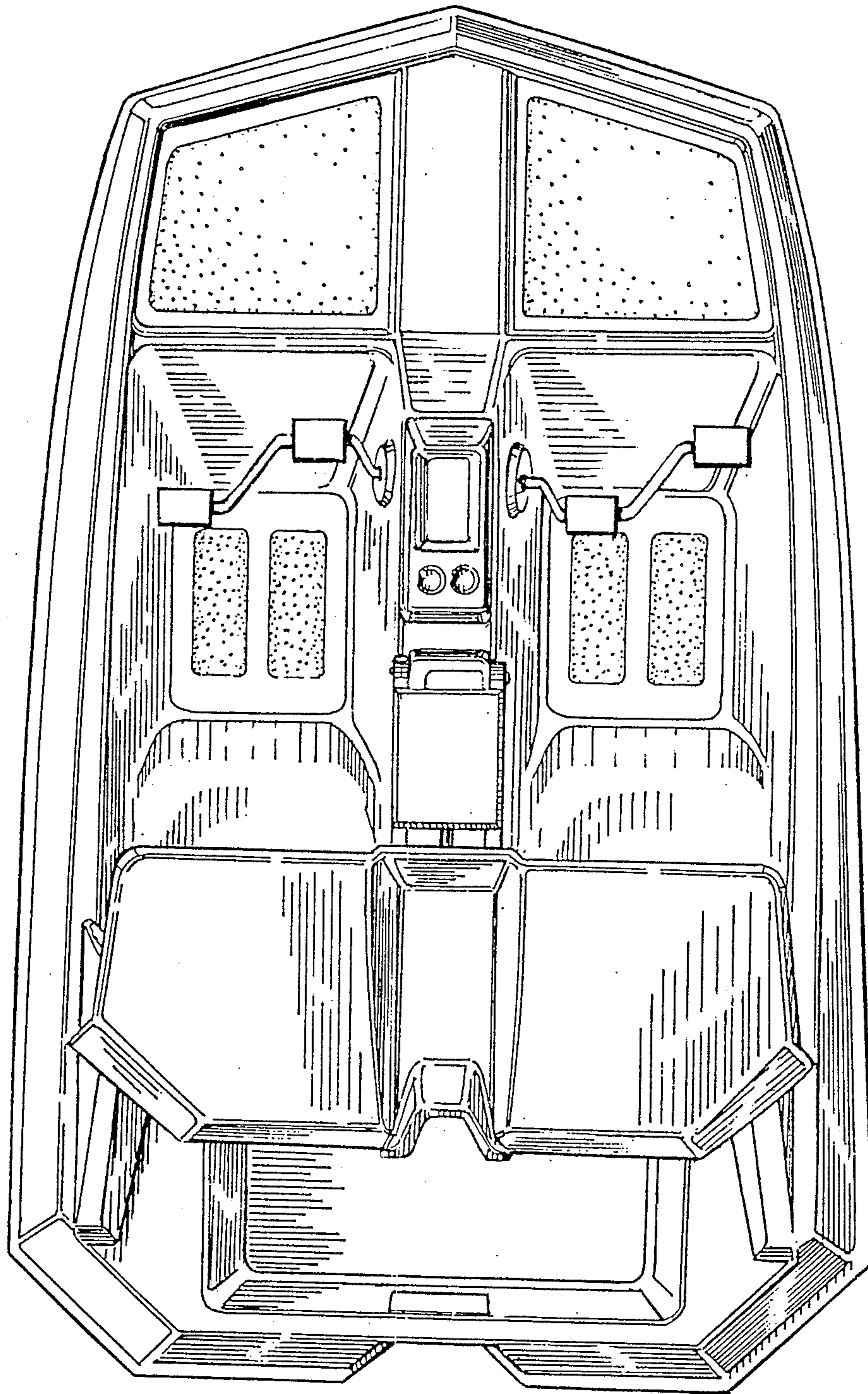

FIG. 3

FIG. 4

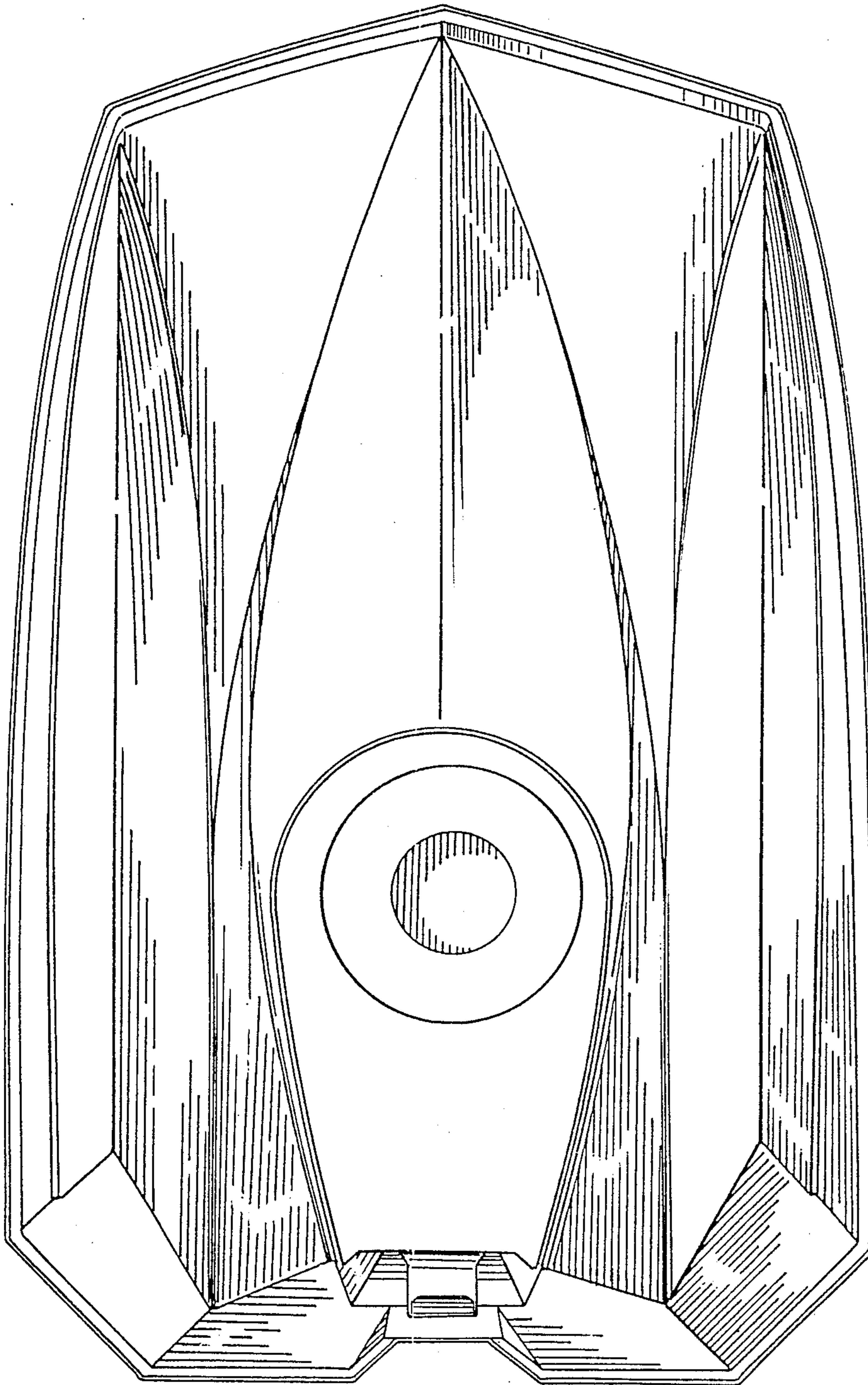

FIG. 5

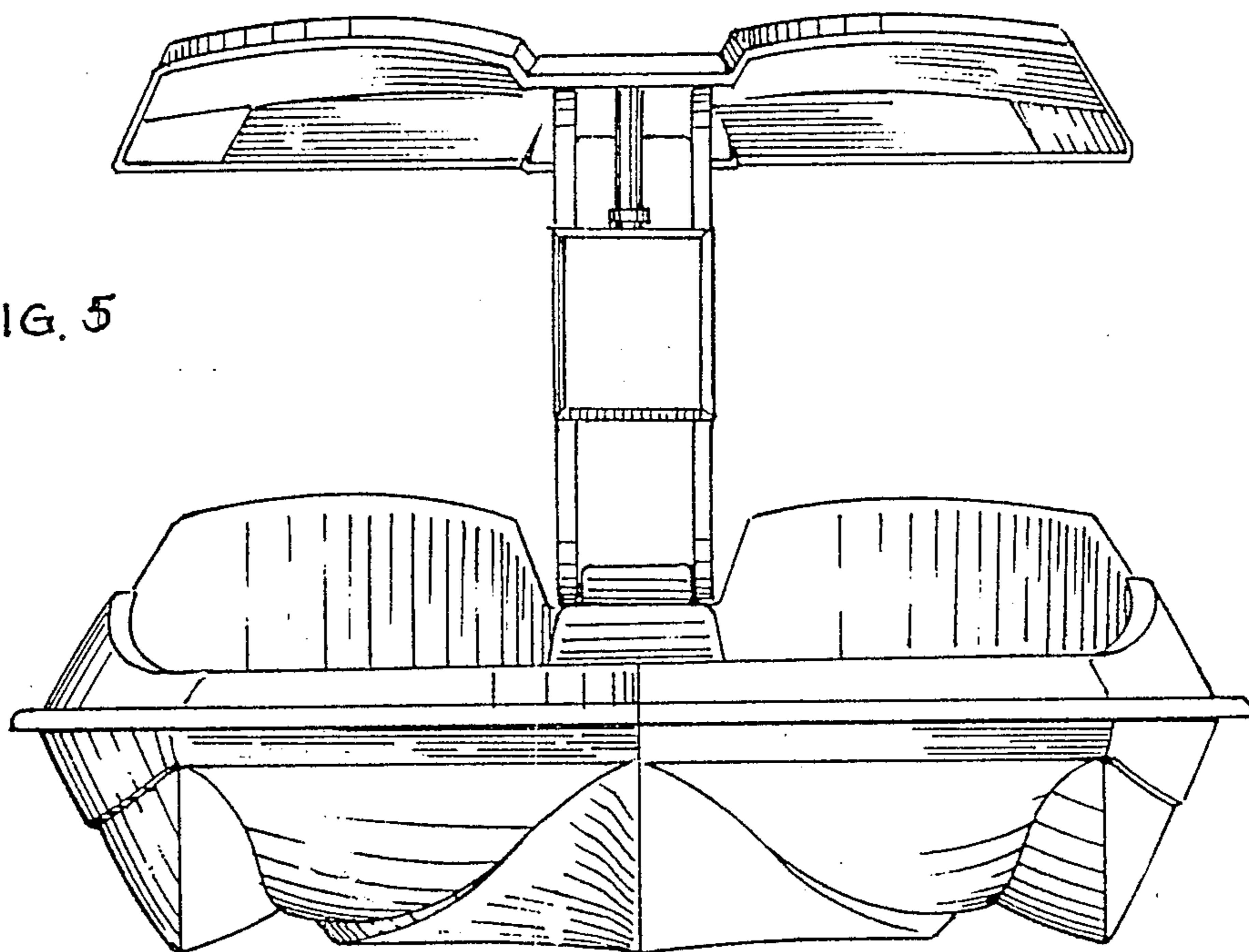

FIG. 6

