

United States Patent [19]

Miyamoto et al.

[11] Patent Number: **Des. 312,227**

[45] Date of Patent: **** Nov. 20, 1990**

[54] **UTILITY VEHICLE**

[75] Inventors: **Shiro Miyamoto, Rancho Palos Verdes; Lloyd Walker, Hermosa Beach, both of Calif.**

[73] Assignee: **Honda Giken Kogyo Kabushiki Kaisha, Tokyo, Japan**

[**] Term: **14 Years**

[21] Appl. No.: **191,594**

[22] Filed: **May 9, 1988**

[52] U.S. Cl. **D12/14; D15/15**

[58] Field of Search **D12/14, 107, 1, 3; D15/15; 296/186, 1.1; 180/233, 54**

[56] **References Cited**

U.S. PATENT DOCUMENTS

D. 227,244 6/1973 Keene D12/1
D. 282,153 1/1986 Wallace et al. D12/14
D. 299,324 1/1989 Oba et al. D12/3

Primary Examiner—James M. Gandy
Assistant Examiner—Melody Brown
Attorney, Agent, or Firm—Lyon & Lyon

[57] **CLAIM**

The ornamental design for a utility vehicle, as shown.

DESCRIPTION

FIG. 1 is a perspective view of a utility vehicle showing our new design;
FIG. 2 is a right side elevation view thereof;
FIG. 3 is a left side elevation view thereof;
FIG. 4 is a top view thereof;
FIG. 5 is a front elevation view thereof; and
FIG. 6 is a rear elevation view thereof.

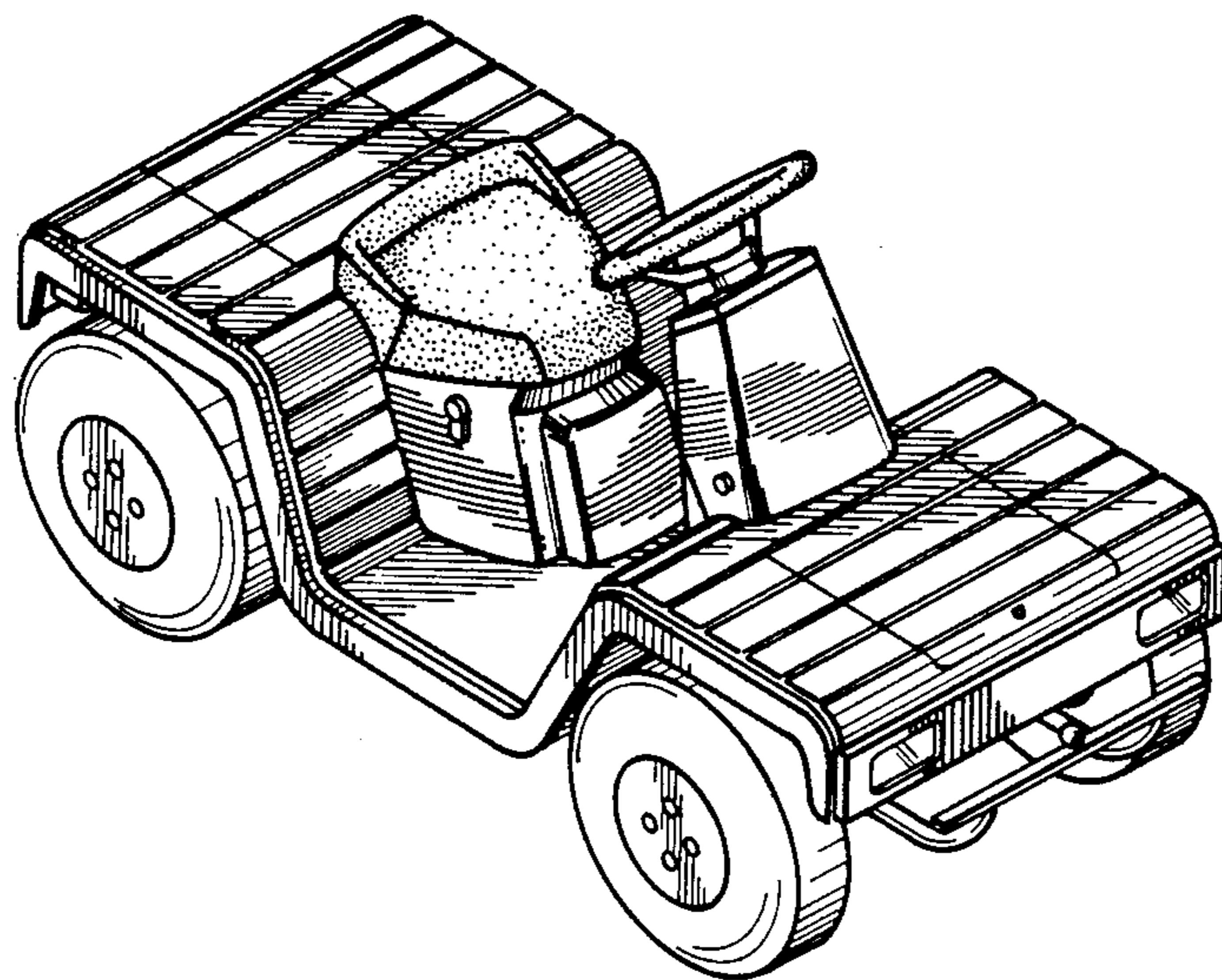

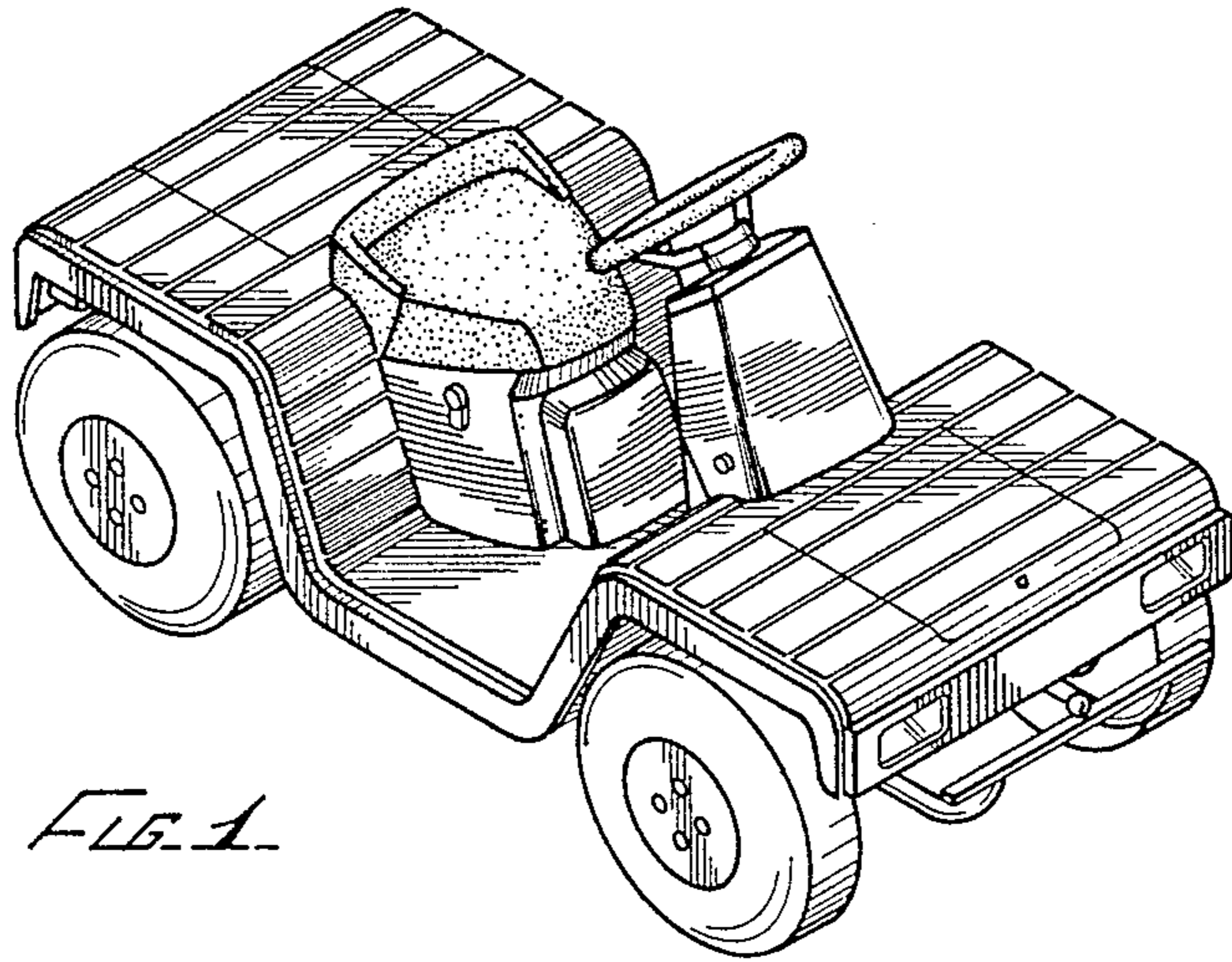

FIG. 1

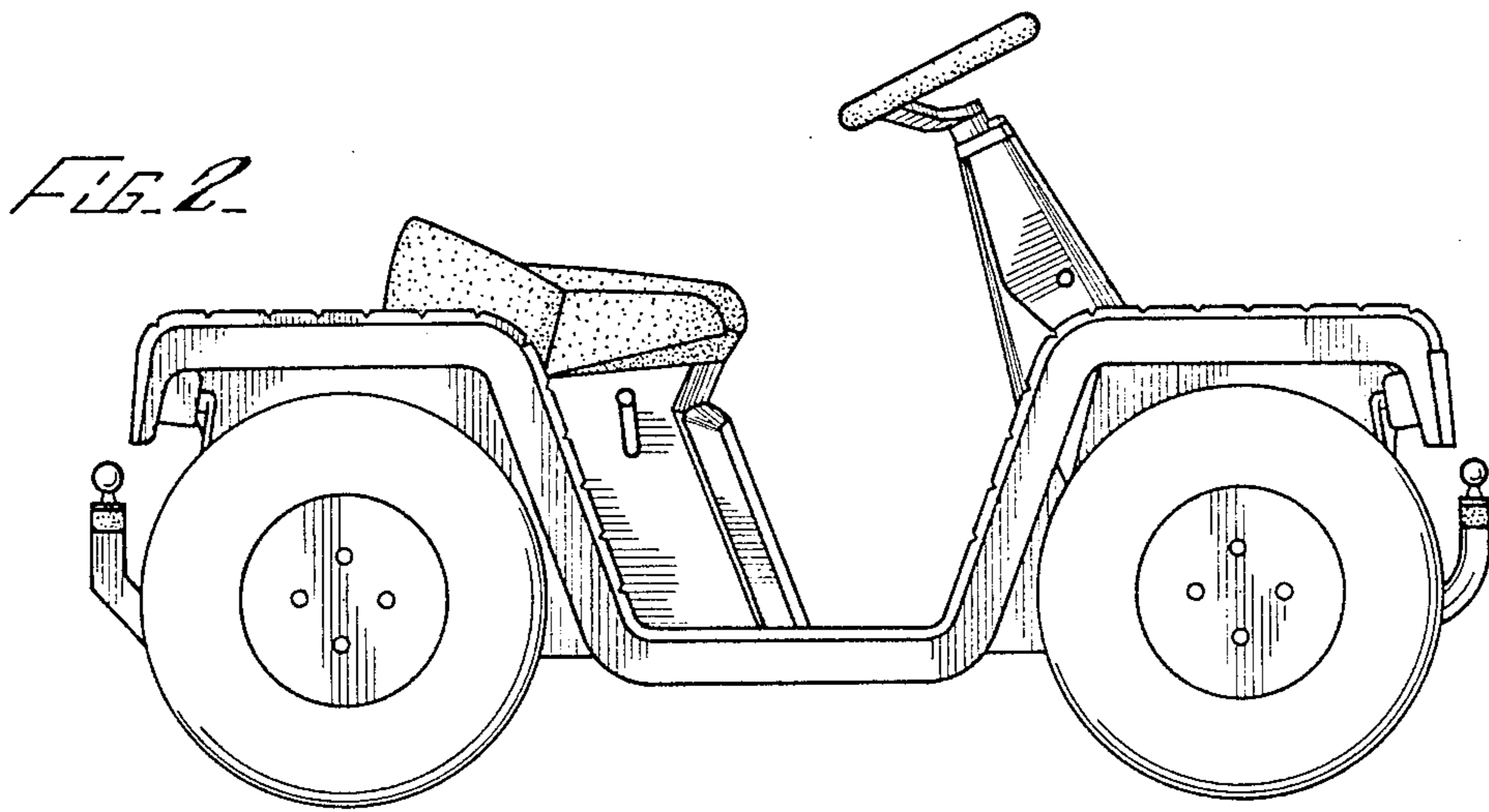

FIG. 2

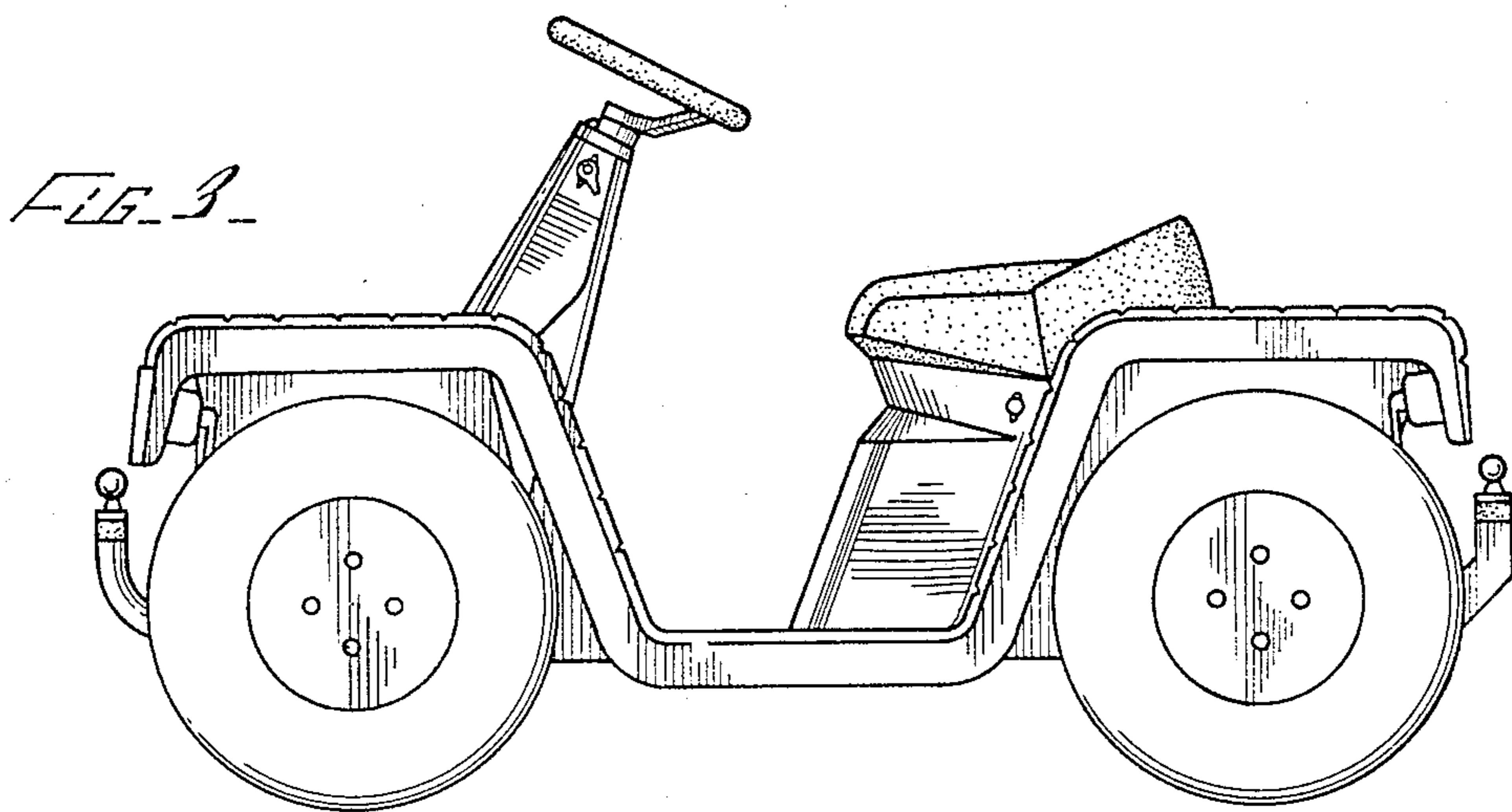

FIG. 3

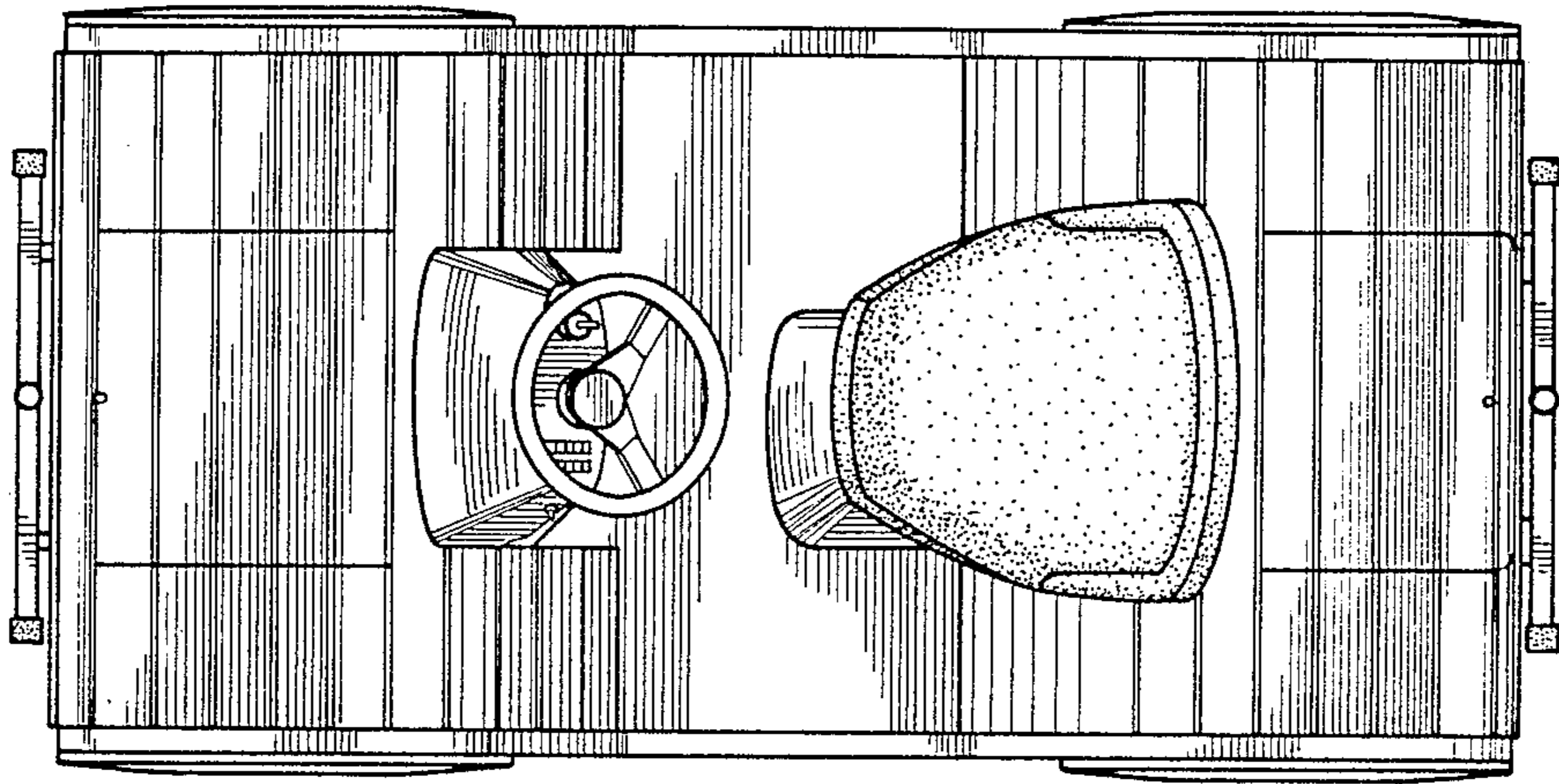

FIG. 4.

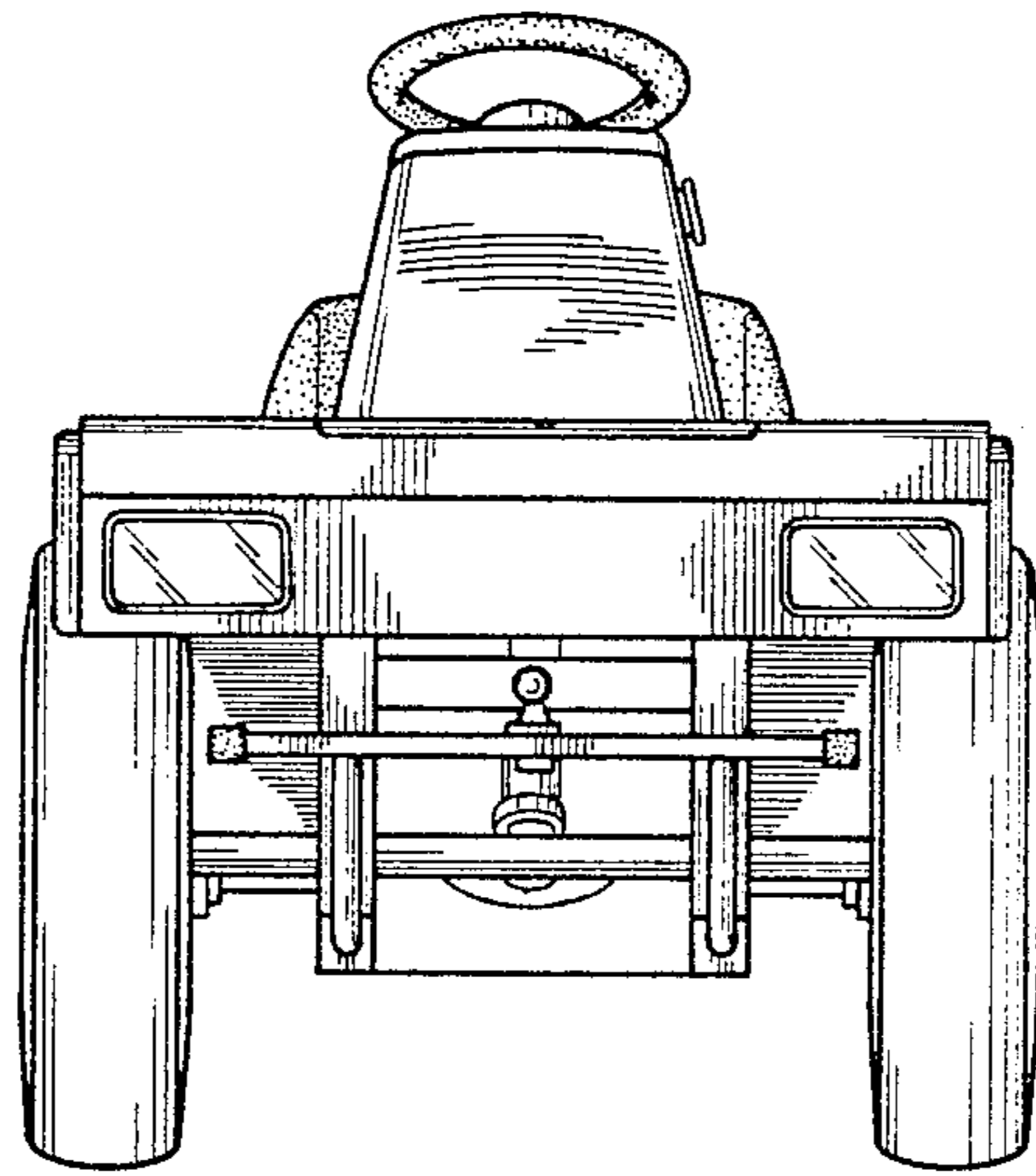

FIG. 5.

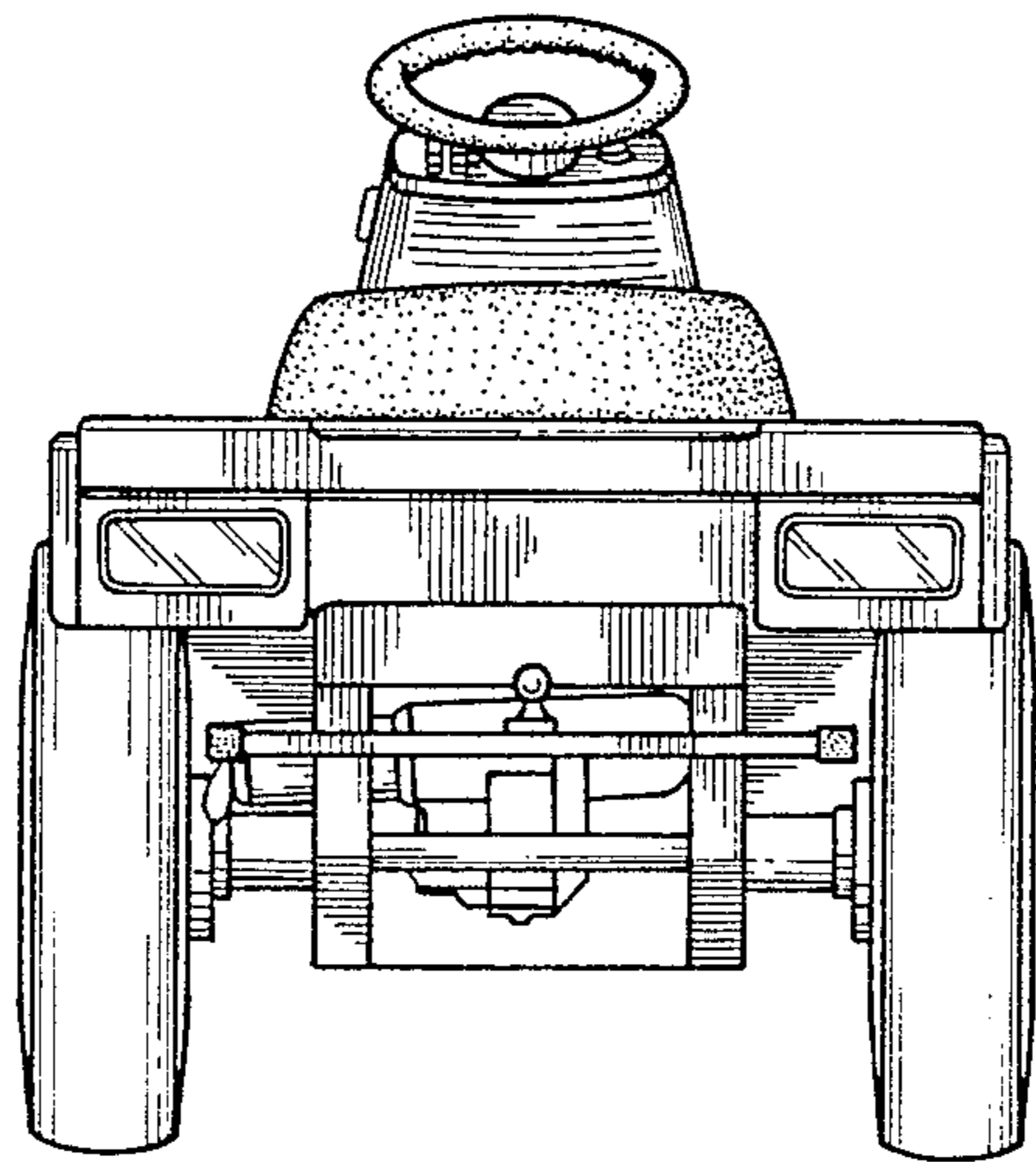

FIG. 6.