

[54] **SINGLE VALANCE BRACKET**
[75] **Inventor: Julius F. John, Redondo Beach, Calif.**
[73] **Assignee: Home Fashions, Inc., Santa Monica, Calif.**
[**] **Term: 14 Years**
[21] **Appl. No.: 196,090**
[22] **Filed: May 19, 1988**
[52] **U.S. Cl. D8/373**
[58] **Field of Search D8/373, 376, 377, 379, D8/400, 368; 160/38, 39; 248/254, 258, 227, 278, 279, 262, 201, 200, 454, 460, 455, 456; 211/43, 184**

3,140,071 7/1964 Norentzen 248/262
3,297,075 1/1967 Howell et al. .
3,347,304 10/1967 Bierlich 160/38
3,469,619 8/1968 Barnett .
3,614,045 1/1969 Cegielski, Jr. .
3,750,894 8/1973 Jensen et al. 211/184
3,818,543 6/1974 Baker, Sr. 16/87.4 R
3,965,540 6/1976 Moore .
3,983,600 10/1976 Smith .
4,079,770 3/1978 Woodle .
4,114,233 9/1978 Hamilton .
4,228,980 10/1980 Beauchamp et al. .
4,254,813 3/1981 Vecchiarelli .
4,254,814 3/1981 Vecchiarelli .
4,335,865 6/1982 Cormier .
4,354,300 10/1982 Anderle 160/38
4,384,605 5/1983 Schaeffer et al. .
4,662,421 5/1987 Basmadji et al. .
4,693,380 9/1987 Muth 211/35

[56] **References Cited**
U.S. PATENT DOCUMENTS

657,538 9/1900 Hellstrom .
1,009,359 11/1911 Walter .
1,431,353 10/1922 Allen 248/262
1,492,200 6/1924 Burns .
1,568,872 12/1924 Briggs .
1,781,262 8/1928 Wintrob .
1,837,632 9/1931 Skowronski .
2,154,909 4/1939 Norentzen 160/38
2,163,511 5/1939 Cardillo .
2,254,019 8/1941 Powell 248/227
2,329,546 3/1943 Lee .
2,452,680 11/1948 Ratcliffe 248/254
2,461,071 2/1949 Mettenleiter 248/227
2,597,578 2/1951 Ganter .
2,604,155 7/1952 Junkunc .
2,986,627 5/1957 Marriett .

Primary Examiner—Wallace R. Burke
Assistant Examiner—Marcus Jackson
Attorney, Agent, or Firm—Welsh & Katz, Ltd.

[57] **CLAIM**

The ornamental design for a single valance bracket, as shown and described.

DESCRIPTION

FIG. 1 is a perspective view of a single valance bracket showing my new design;
FIG. 2 is a top plan view thereof;
FIG. 3 is a front elevational view thereof;
FIG. 4 is a right side elevational view, with the opposite side being a mirror image thereof;
FIG. 5 is a rear elevational view thereof;
FIG. 6 is a bottom plan view thereof.

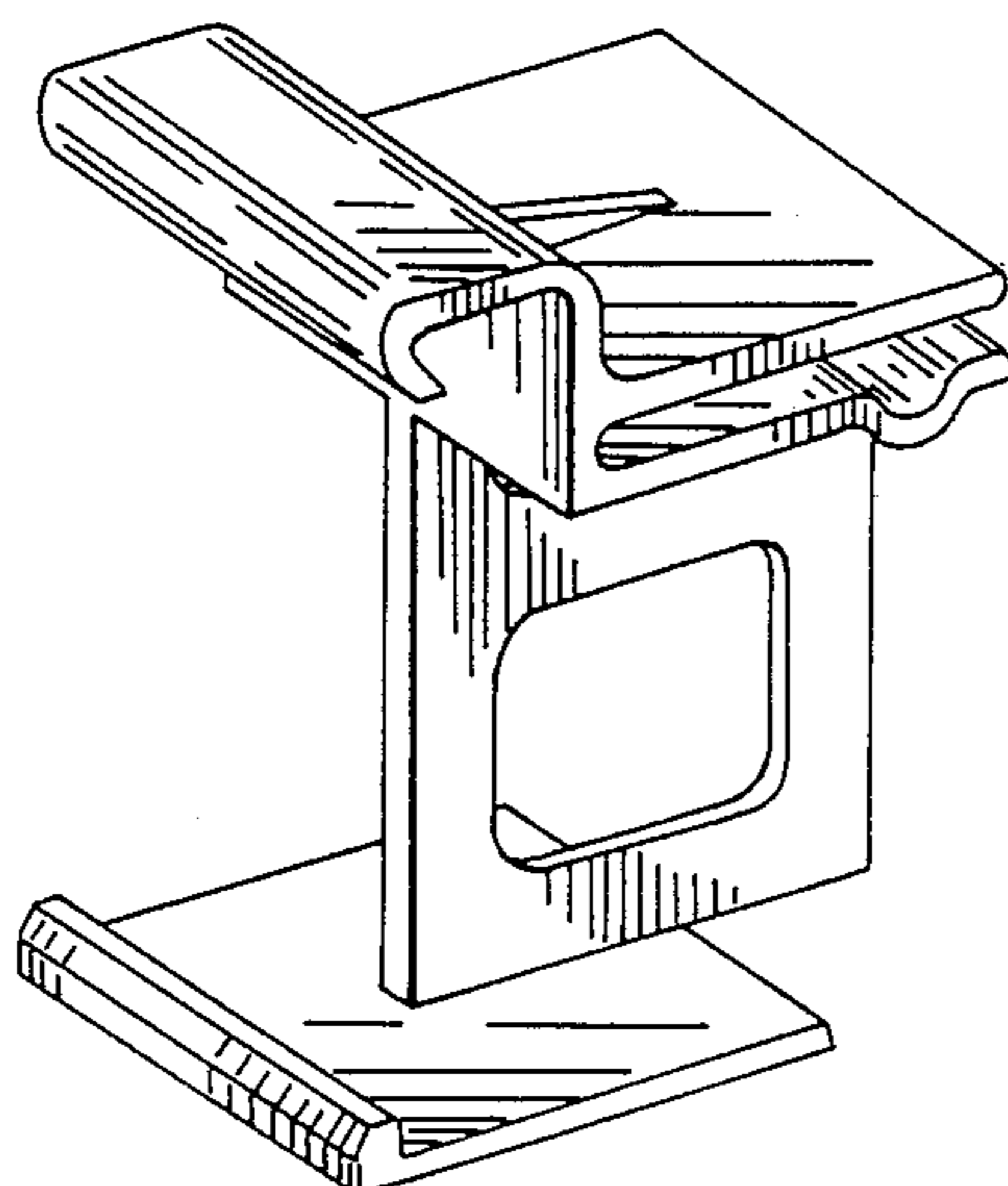

FIG. 1.

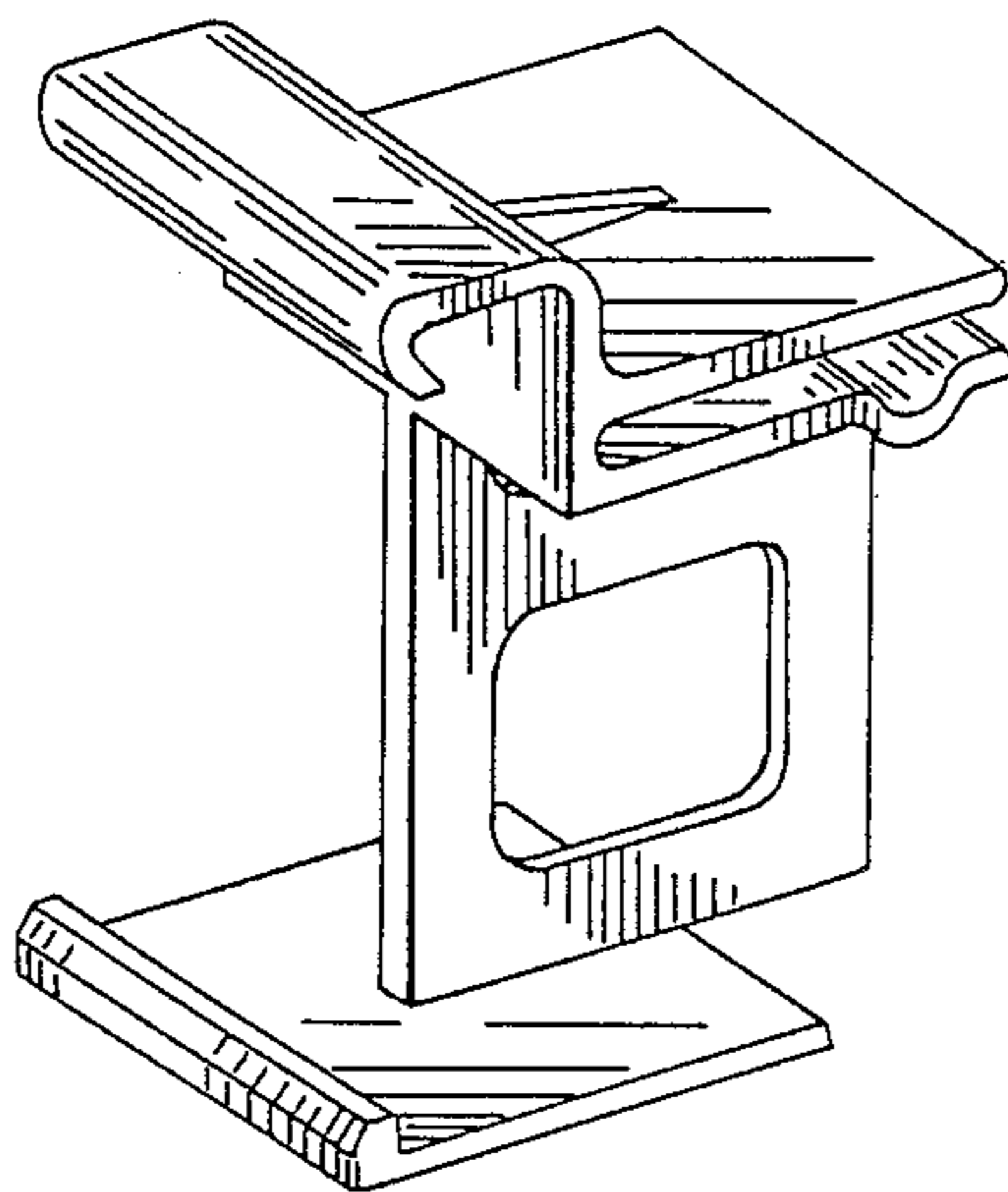

FIG. 2.

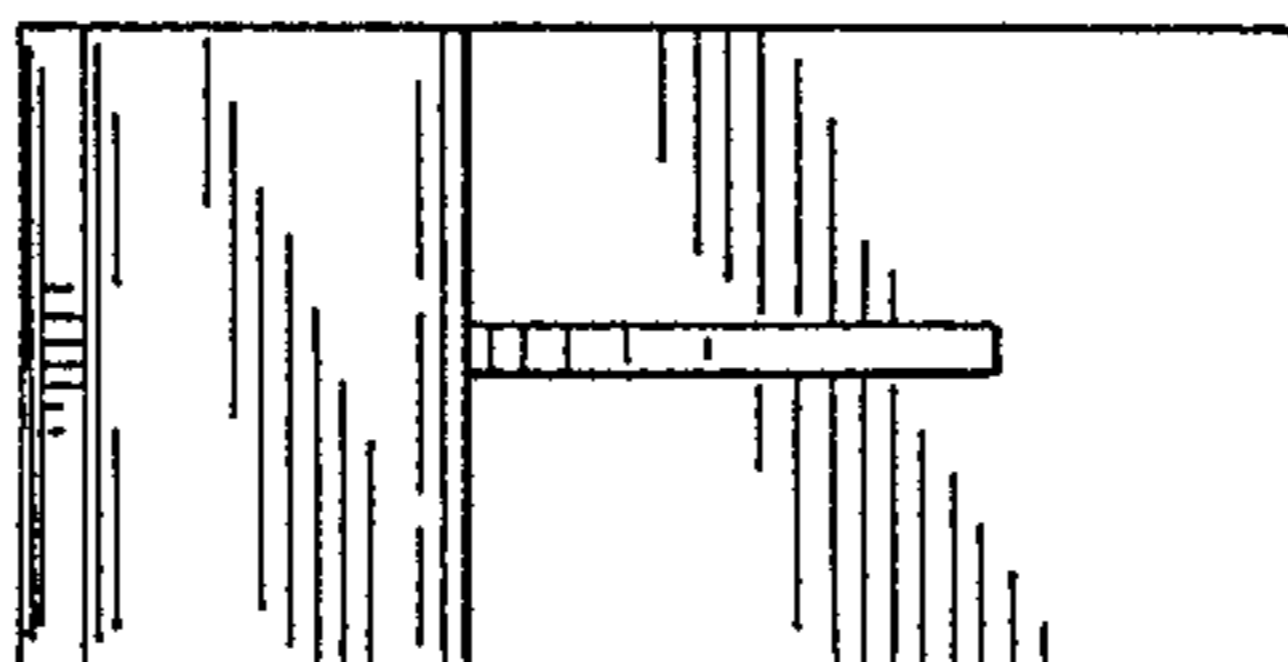

FIG. 3.

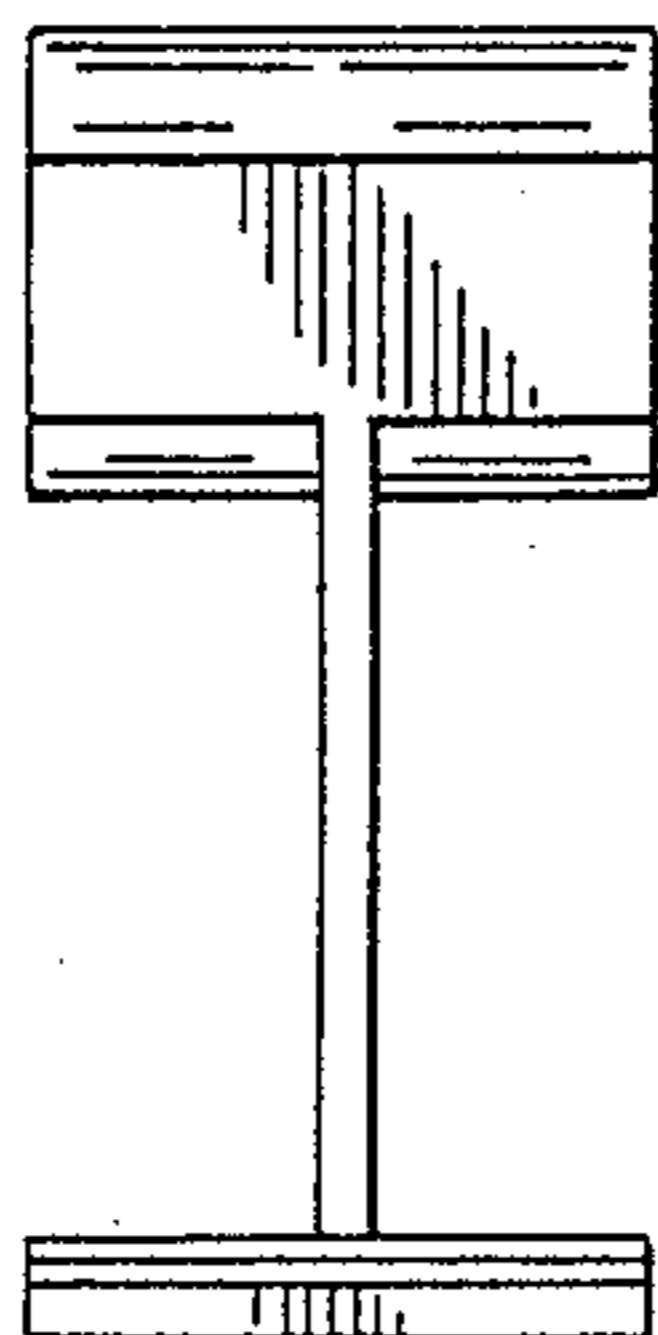

FIG. 4.

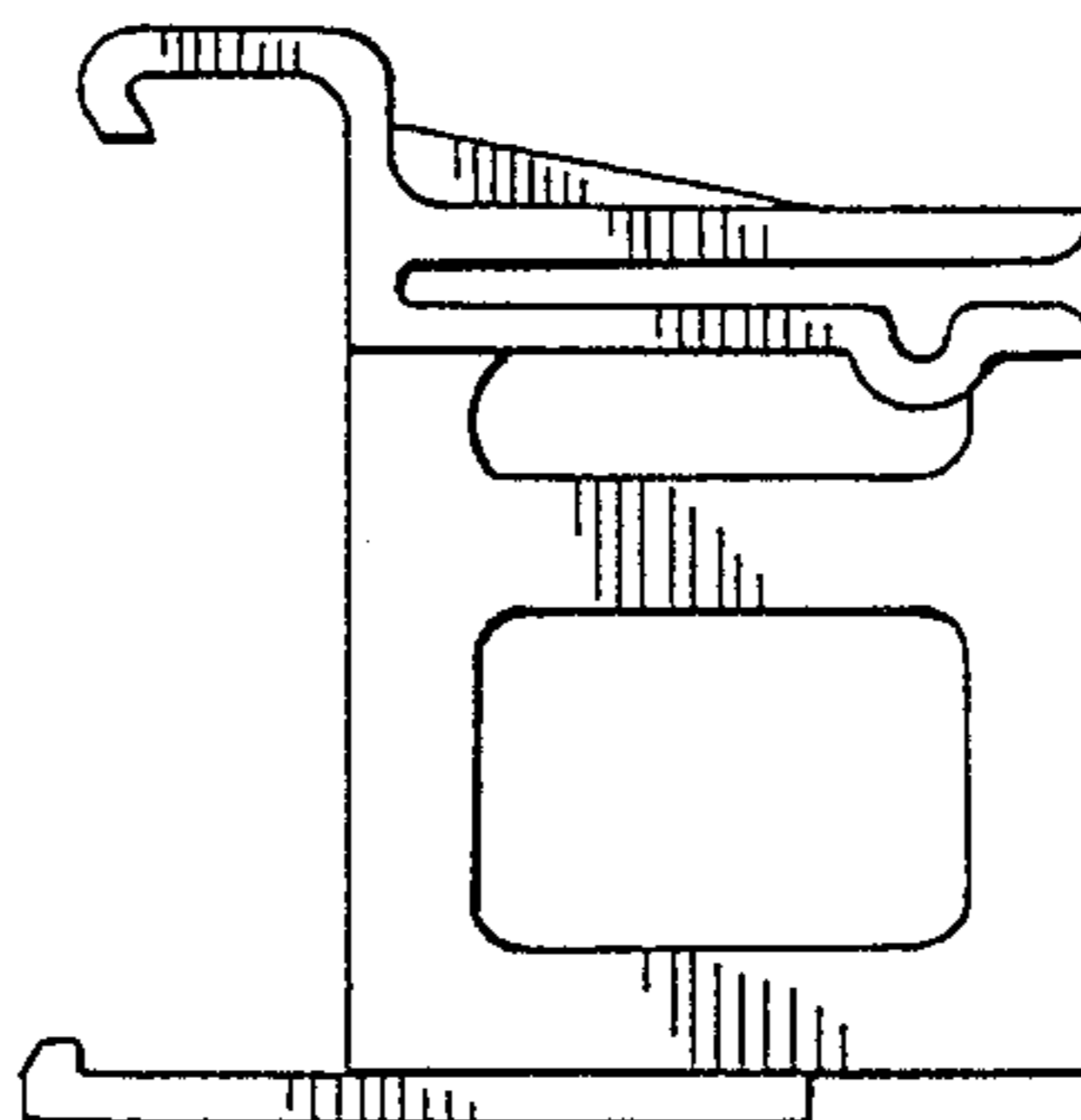

FIG. 5.

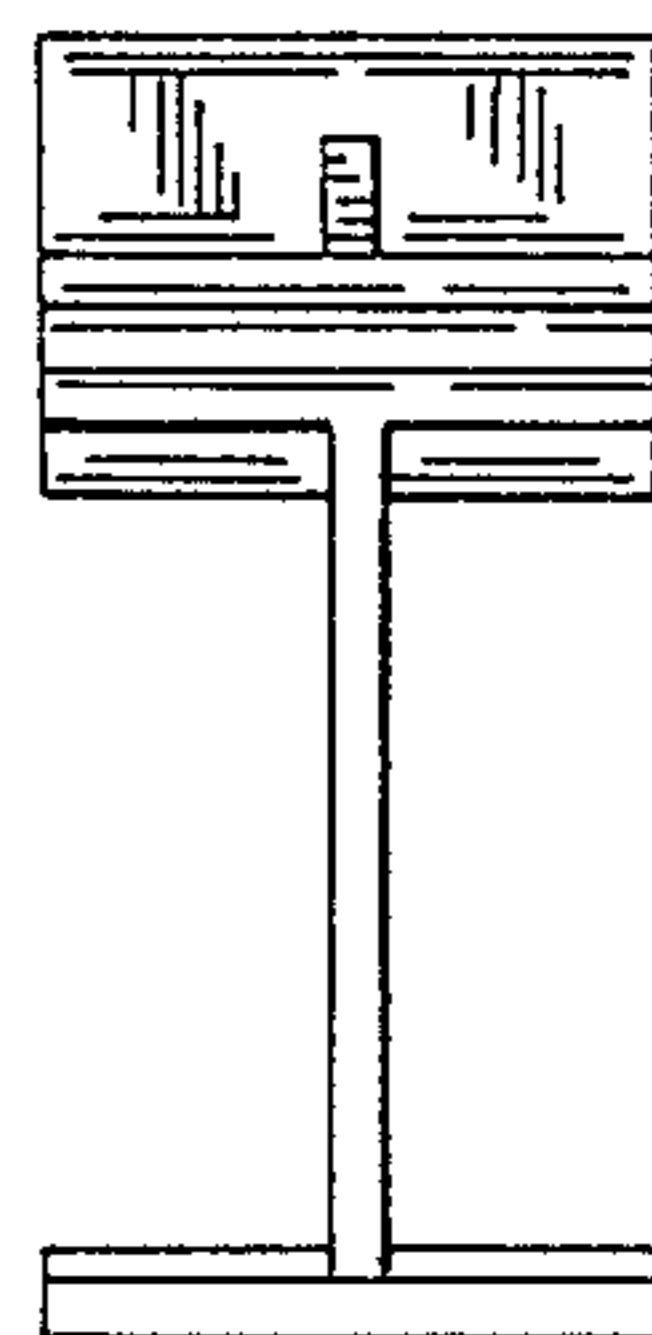

FIG. 6.

