

[54] **NURSING BOTTLE HOLDER**
[76] **Inventor: Donald D. Ahlerich, 6715 Briarfield St., Spring, Tex. 77379**
[**] **Term: 14 Years**
[21] **Appl. No.: 862,516**
[22] **Filed: May 12, 1986**
[52] **U.S. Cl. D8/14**
[58] **Field of Search D8/14, 51, 105; 29/270, 29/278; D24/48; 248/102-107**

2,881,999 4/1959 Mitchell .
2,931,608 4/1960 Farah .
3,222,020 12/1965 Rea 248/106
4,309,008 1/1982 Sirks .
4,513,935 4/1985 Aquirre .

Primary Examiner—Bruce W. Dunkins
Assistant Examiner—Janice Seeger
Attorney, Agent, or Firm—T. M. Gernstein

[56] **References Cited**
U.S. PATENT DOCUMENTS
D. 124,904 1/1941 Palmer .
D. 162,117 2/1951 Battle .
D. 186,296 10/1959 Rutledge D24/48
2,490,207 12/1949 Cassile .
2,638,296 5/1953 Battle 248/105
2,639,111 5/1953 Wells .
2,830,781 4/1958 Coulter D24/48

[57] **CLAIM**
The ornamental design for a nursing bottle holder, as shown and described.

DESCRIPTION
FIG. 1 is a top plan view of a nursing bottle holder showing my new design;
FIG. 2 is a right side elevational view thereof;
FIG. 3 is an end elevational view thereof, the opposite end being a mirror image;
FIG. 4 is a left side elevational view; and
FIG. 5 is a bottom perspective view thereof.

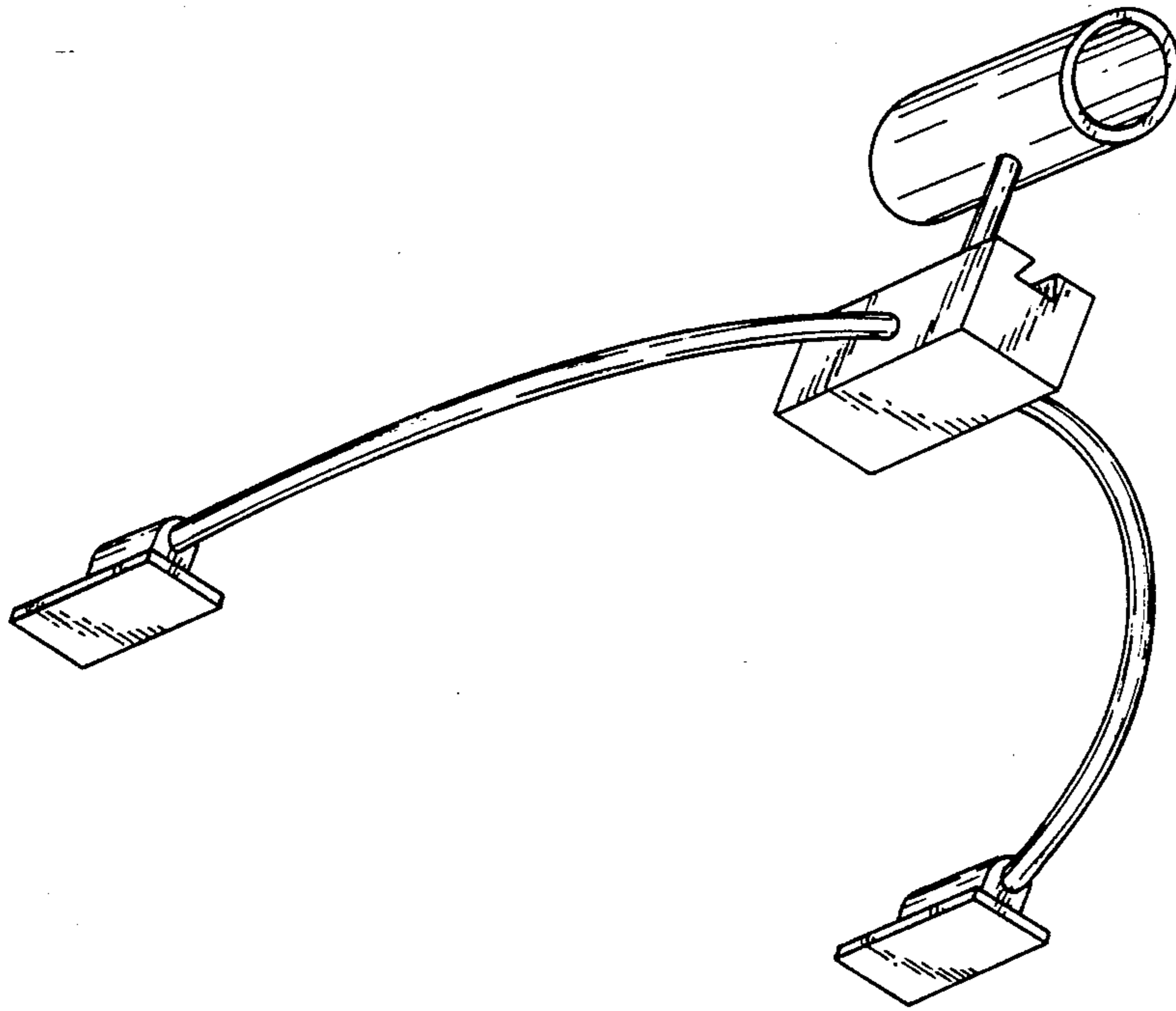

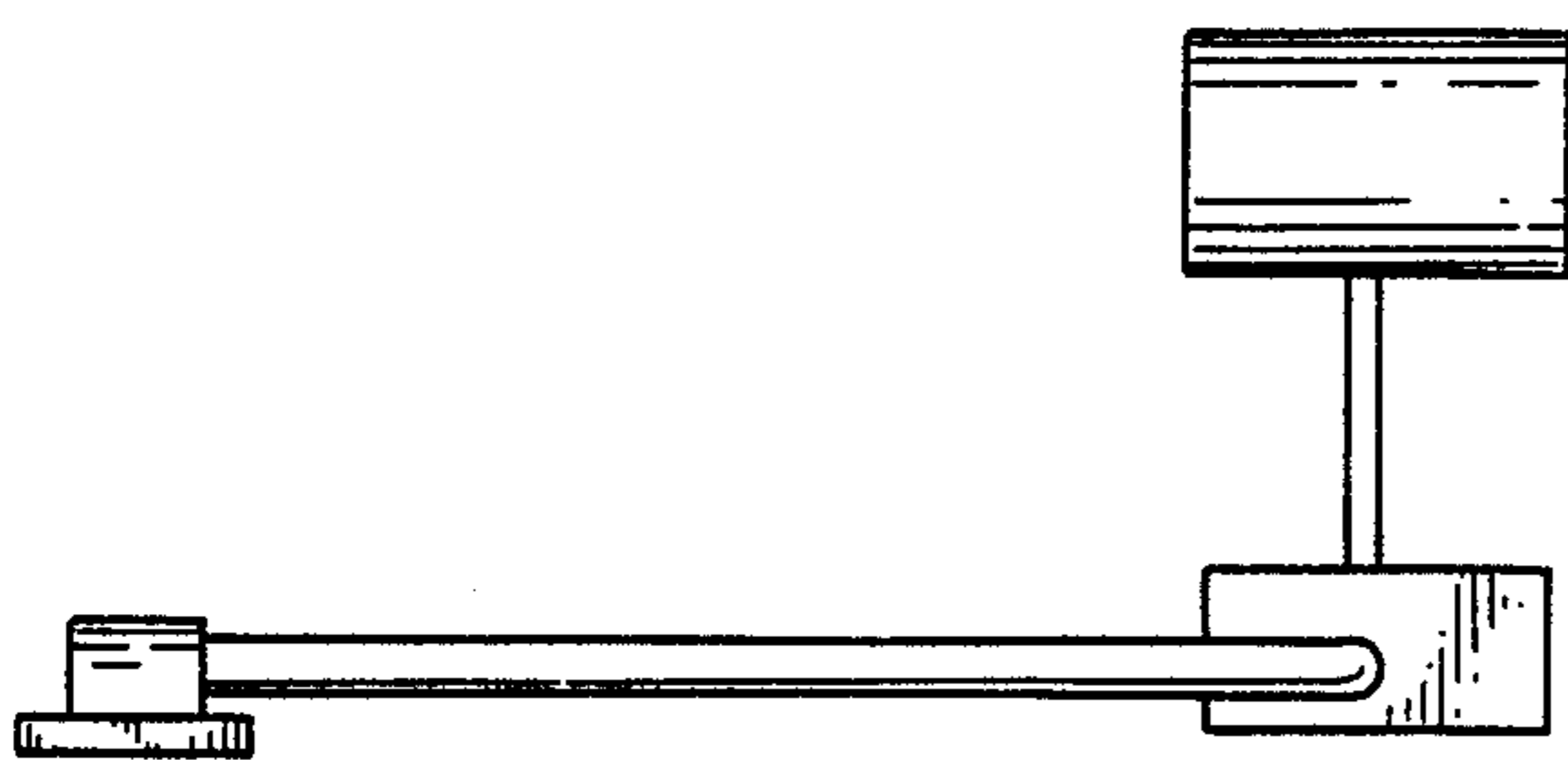
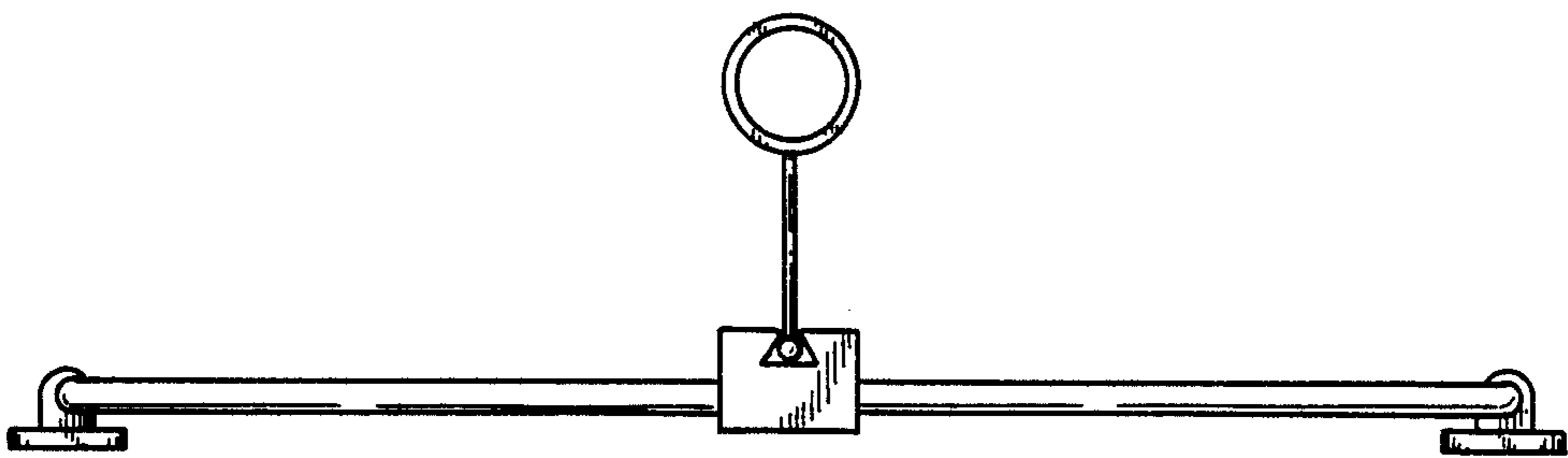
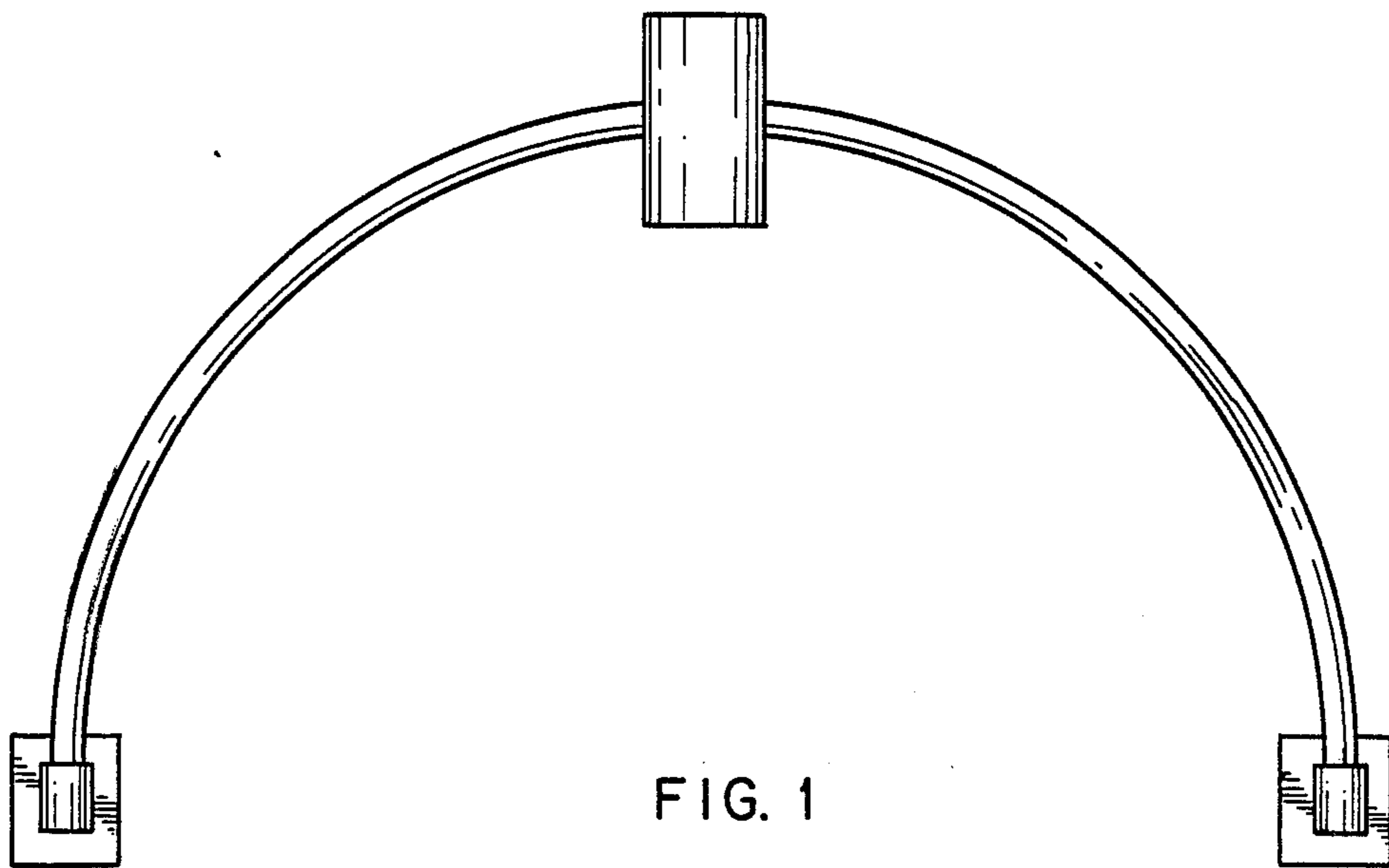

FIG. 5

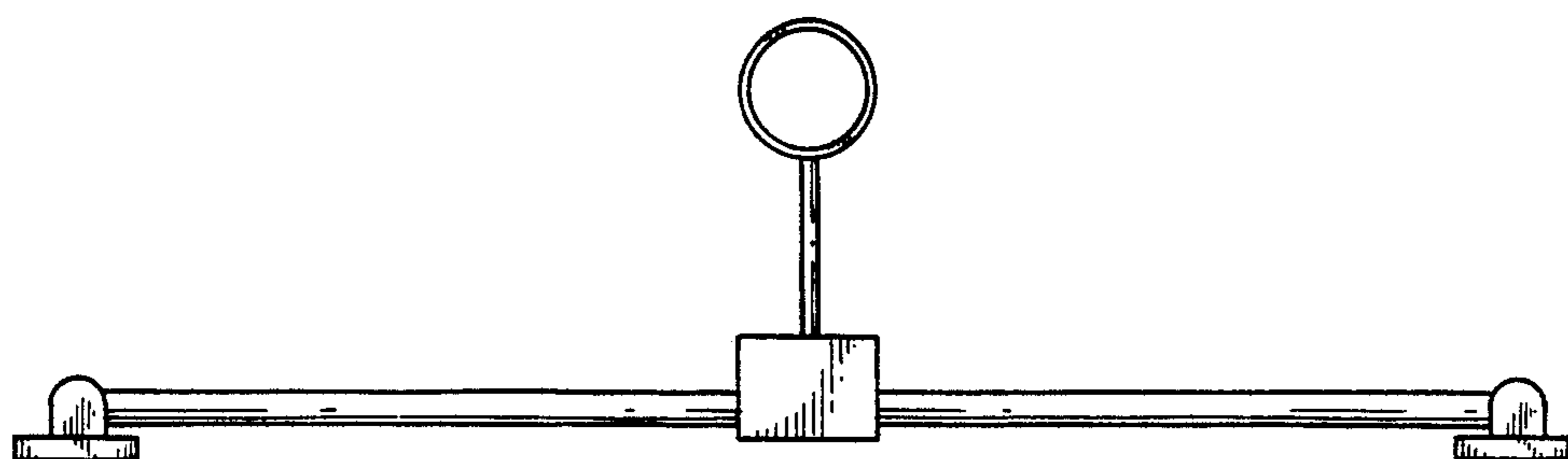
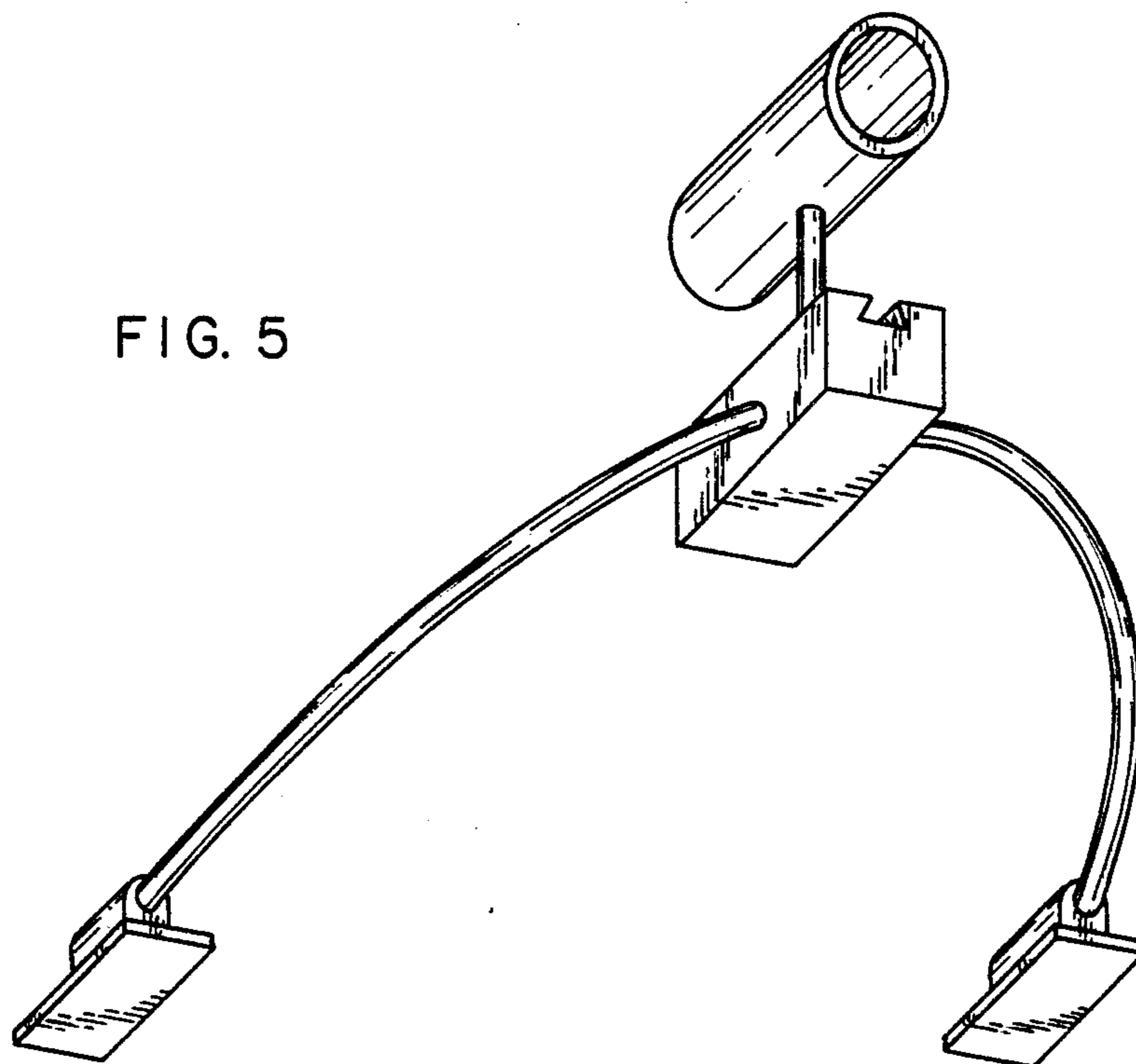

FIG. 4