

[54] MANIFOLD VALVE UNIT

[76] Inventor: Andy R. Askew, 2240 Chipwood La., Winston-Salem, N.C. 27106

[**] Term: 14 Years

[21] Appl. No.: 41,320

[22] Filed: Apr. 22, 1987

[52] U.S. Cl. D23/245

[58] Field of Search D23/233.5, 245.7; 137/884, 868, 867, 871, 636, 595

[56] References Cited

U.S. PATENT DOCUMENTS

D. 139,952	8/1943	Kehle	D23/245
D. 142,703	7/1945	Collins	D23/245
D. 166,173	5/1951	Burrows	D23/245
D. 223,095	9/1970	Allen	D23/233
D. 264,388	5/1982	Dryden	D23/235 X
D. 266,863	11/1982	Mason	D23/233
D. 273,698	5/1984	Pace	D23/248
1,486,304	3/1921	Ross	137/868 X
2,616,658	11/1952	Dombeck	D23/245 X
2,745,628	5/1956	Carlson	251/241 X
3,092,141	6/1963	Stark	137/884 X
3,098,501	7/1963	McLeod	137/505.13
3,259,145	7/1966	Engle	137/884

3,323,545	6/1967	Carls	137/884 X
3,598,364	8/1971	Greenier	137/231
4,067,546	1/1978	Matsuda et al.	137/636 X
4,382,452	5/1983	Loveless	137/884 X
4,498,500	2/1985	Miller	137/884 X
4,574,844	3/1986	Neff et al.	137/884 X

FOREIGN PATENT DOCUMENTS

1276132	10/1960	France	137/867
---------	---------	--------	-------	---------

Primary Examiner—James R. Largen
Assistant Examiner—Demetrius Reynolds
Attorney, Agent, or Firm—Michael W. York

[57] CLAIM

The ornamental design for a valve module, substantially as shown and described.

DESCRIPTION

FIG 1 is a perspective view taken from the top, front and left side of a manifold valve unit showing my new design;
FIG. 2 is a front elevational view thereof;
FIG. 3 is a right side elevational view thereof;
FIG 4 is a left elevational view thereof;
FIG. 5 is a top plan view thereof;
FIG. 6 is a bottom plan view thereof; and
FIG. 7 is a rear elevational view thereof.

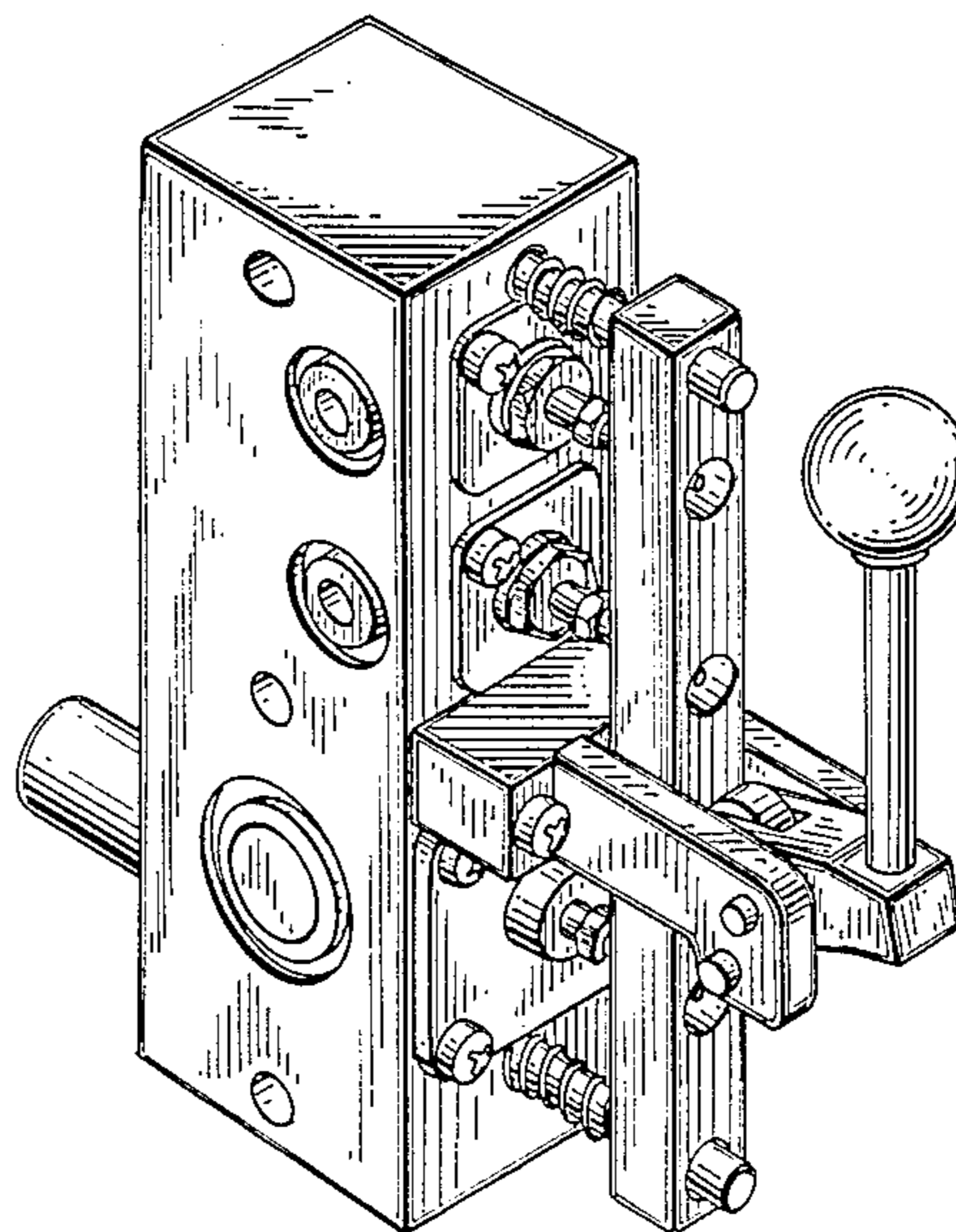

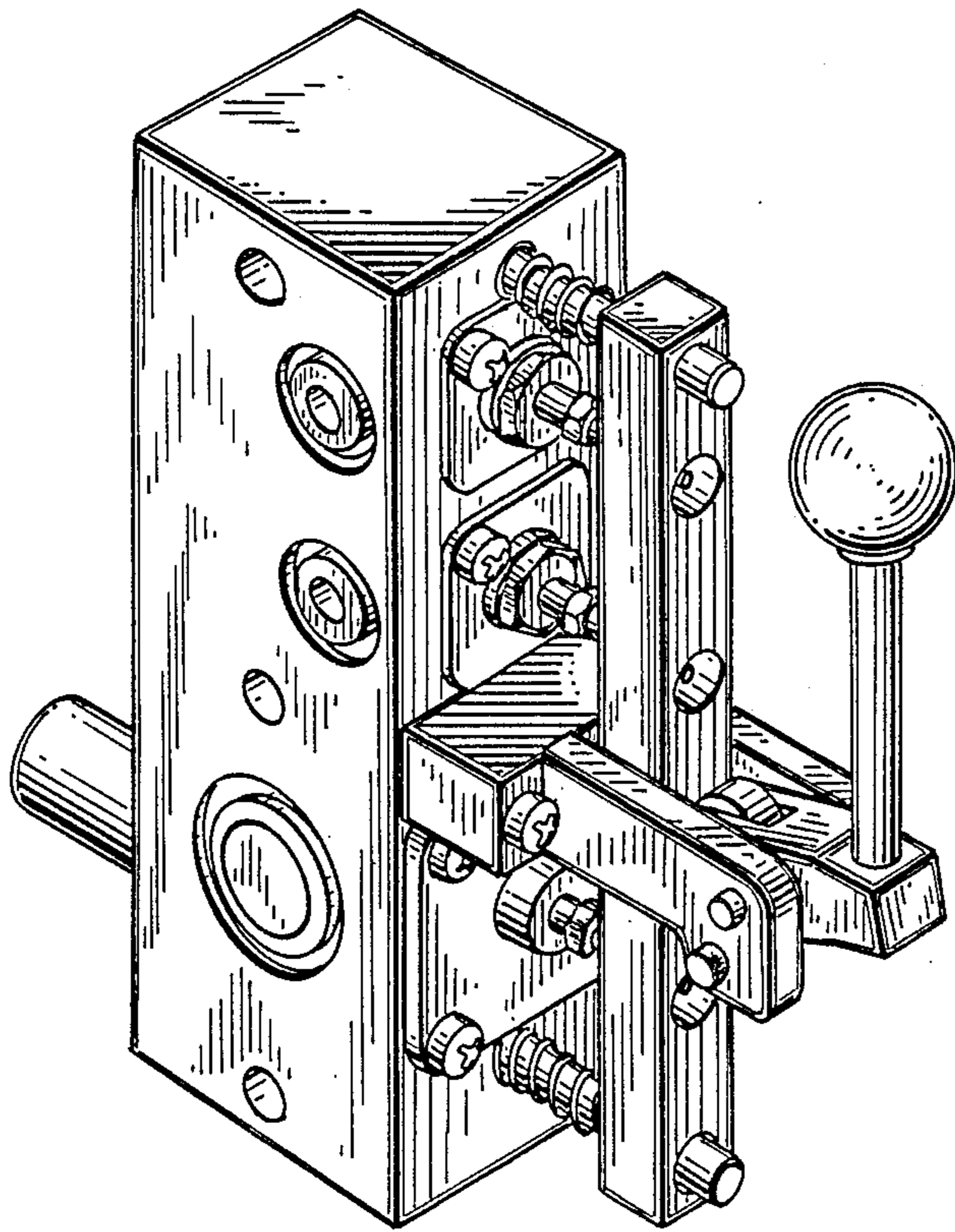

Fig. 1

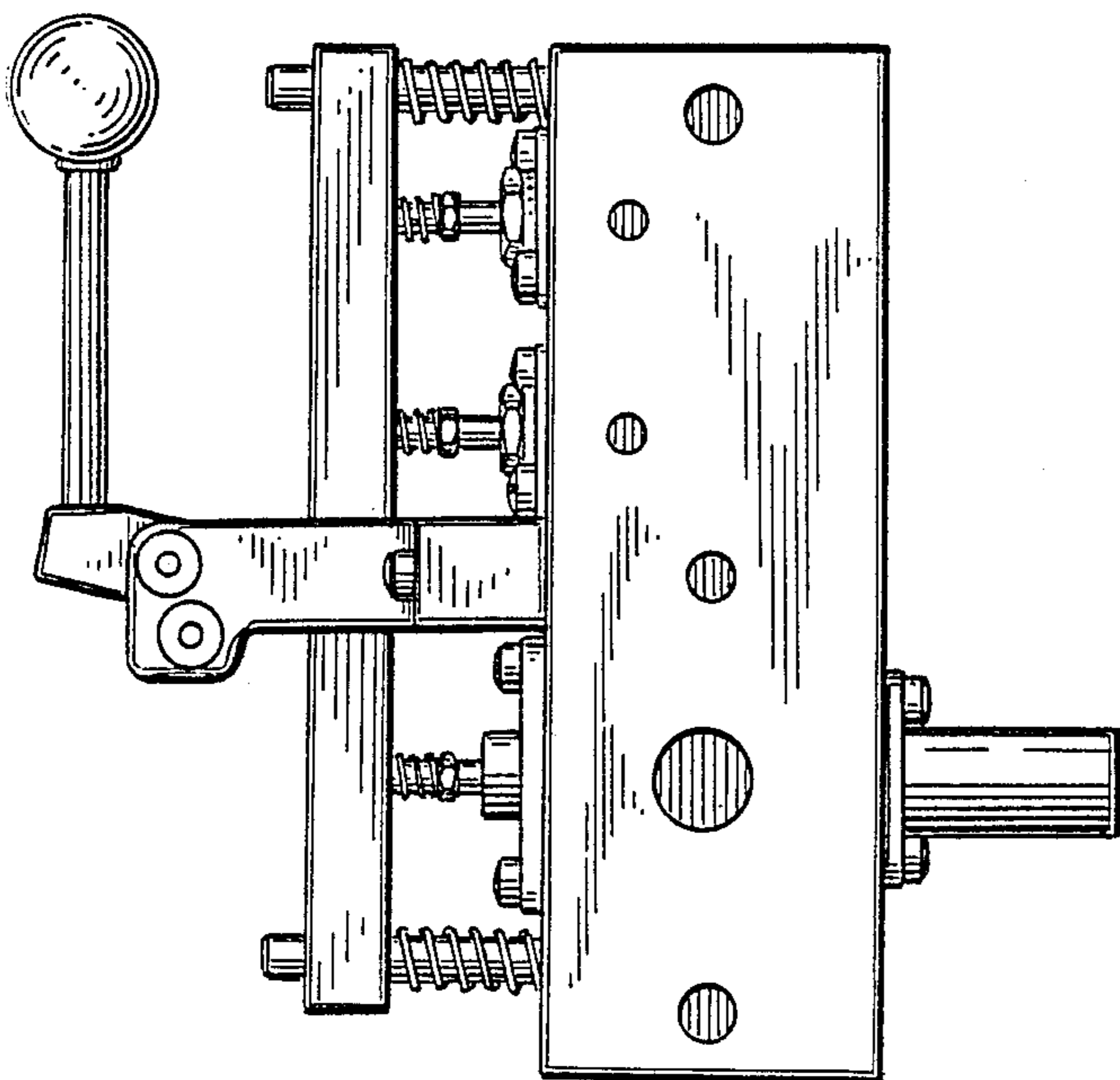

Fig. 2

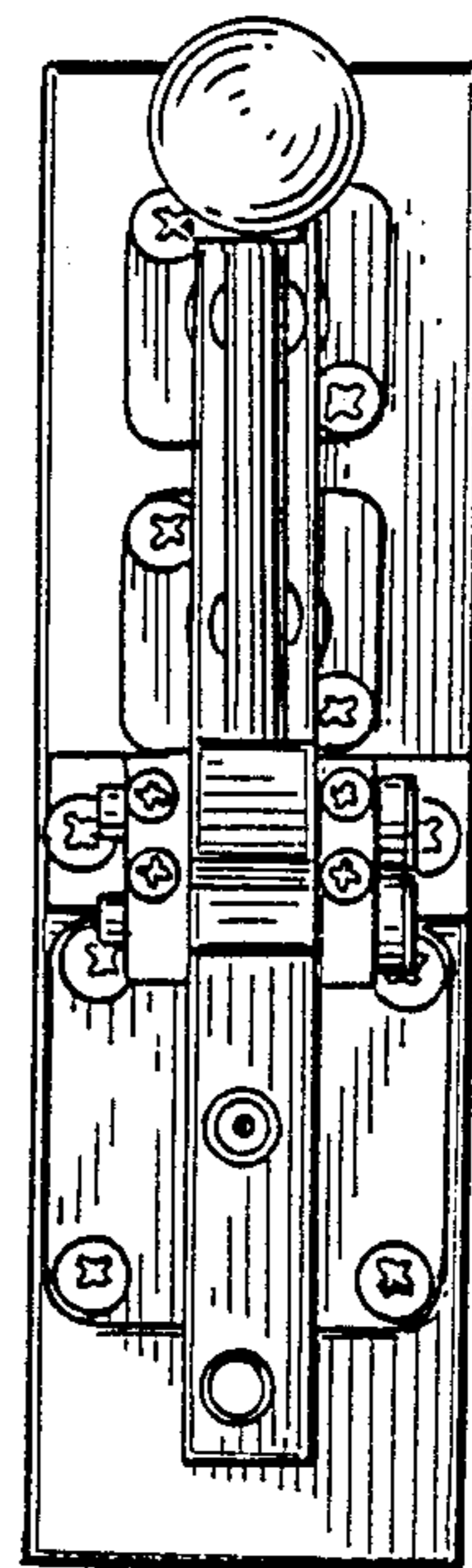

Fig. 3

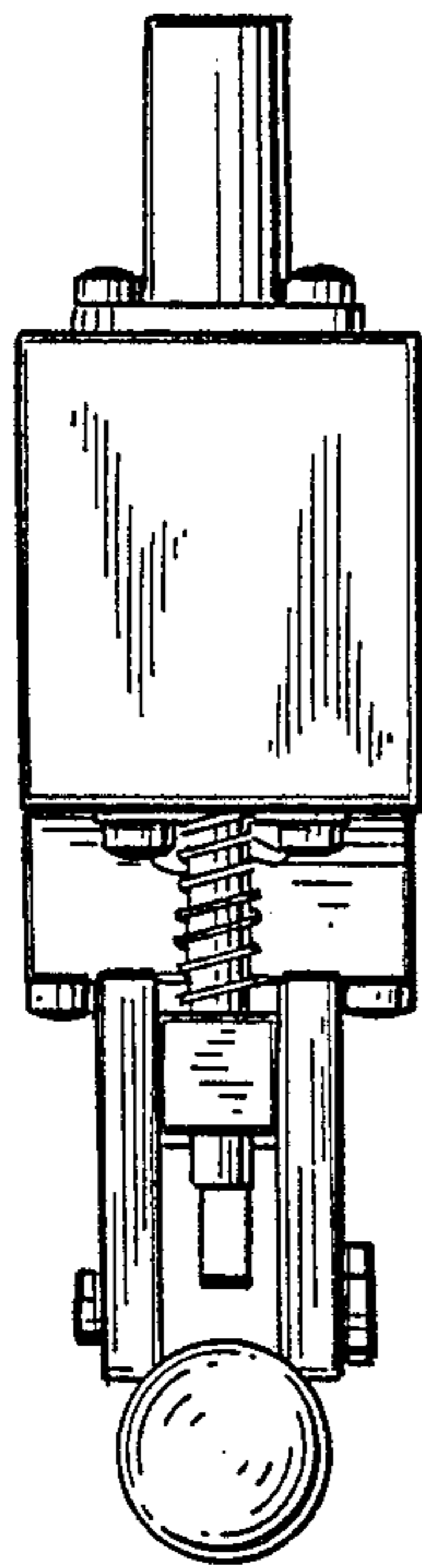

Fig. 5

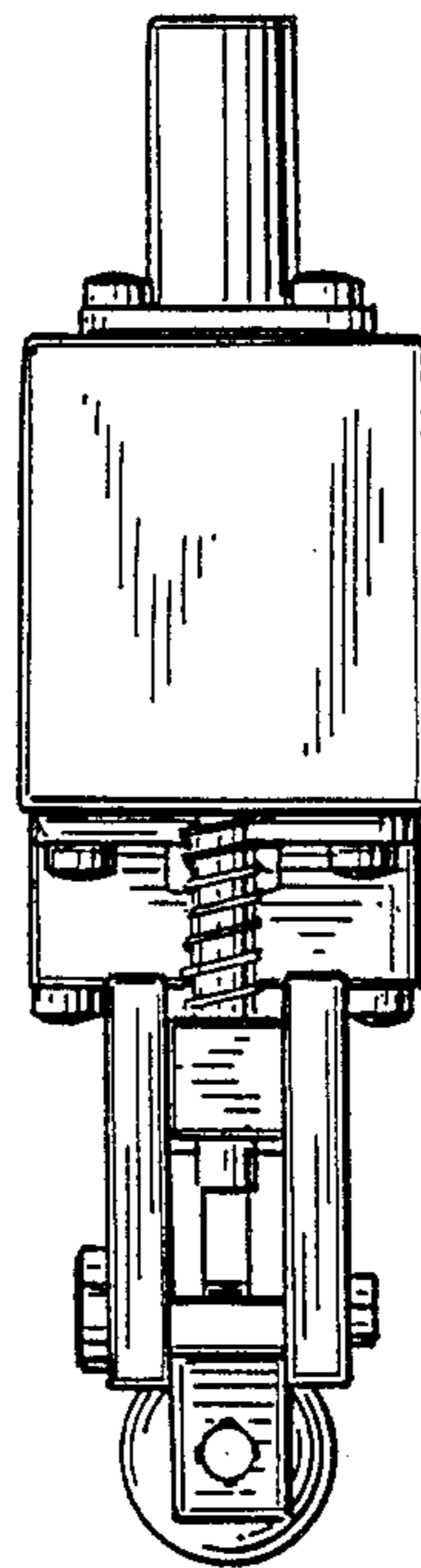

Fig. 6

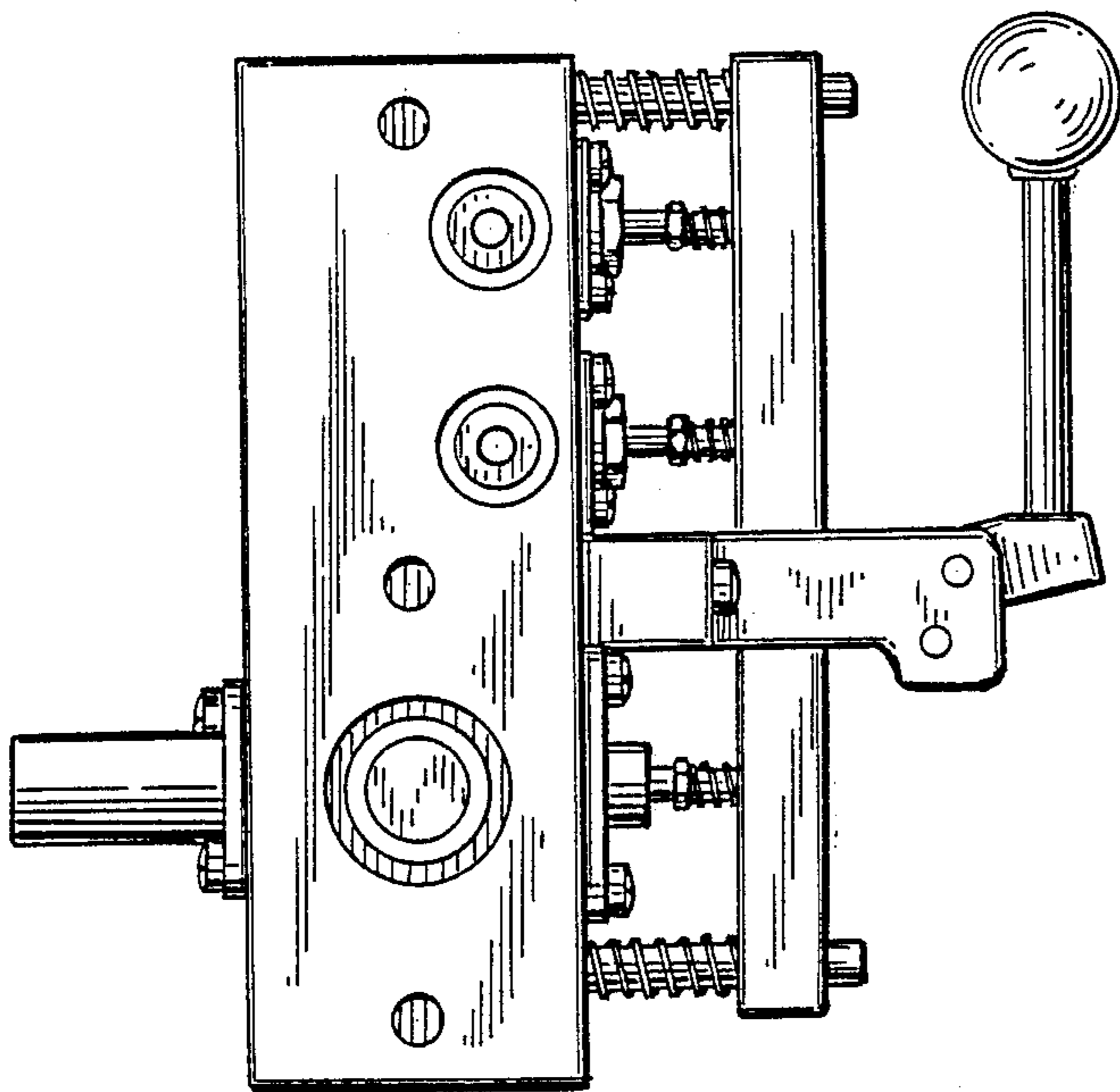

Fig. 4

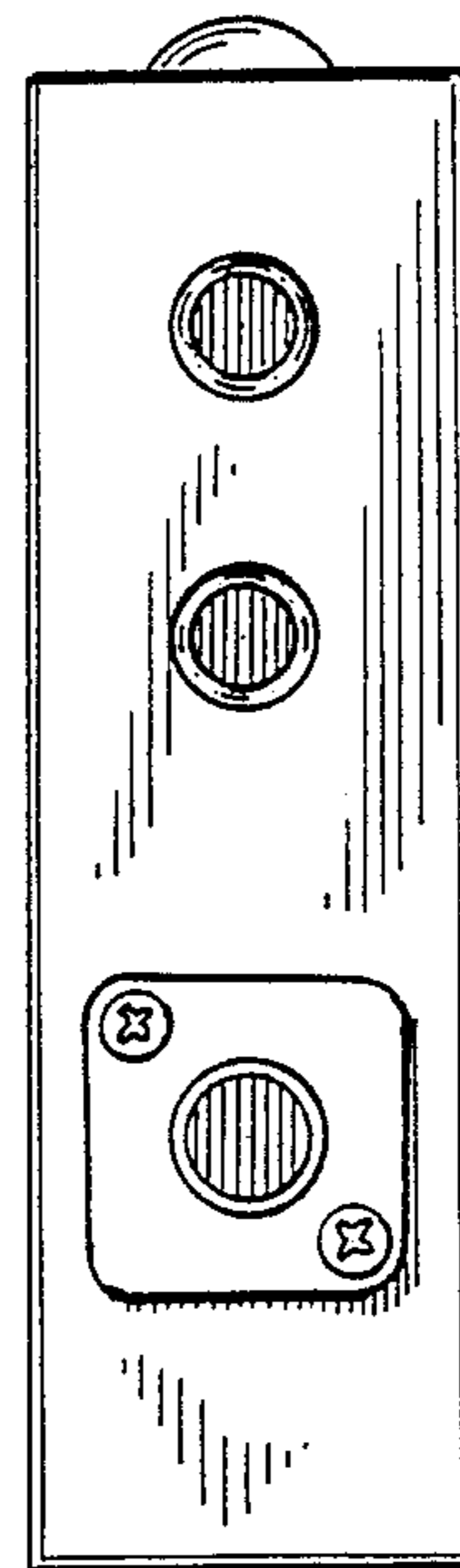

Fig. 7