

[54] GAME BOARD

3,930,652 1/1976 Lapolice ..... 273/285

[75] Inventor: David E. Titchener, Swindon, England

Primary Examiner—Louis S. Zarfes  
Assistant Examiner—R. T. Seifert

[73] Assignee: Anjar Company, New York, N.Y.

[57] CLAIM

[\*\*] Term: 14 Years

The ornamental design for a game board, as shown and described.

[21] Appl. No.: 43,237

DESCRIPTION

[22] Filed: Apr. 27, 1987

[52] U.S. Cl. .... D21/14

[58] Field of Search ..... D21/14, 112, 111;  
D14/121; 273/285, 287

FIG. 1 is a front elevational view of a game board showing my new design;

FIG. 2 is a side elevational view, the opposite side being a mirror image;

FIG. 3 is a bottom plan view;

FIG. 4 is a top plan view;

FIG. 5 is a rear elevational view;

FIG. 6 is a perspective view with the game board in a partially extended position; and

FIG. 7 is an exploded perspective view with the game board in a fully extended position with the storage cover removed and playing pieces exposed.

[56] References Cited

U.S. PATENT DOCUMENTS

D. 223,029	2/1972	Weiss	.....	D14/121
D. 283,336	4/1986	Matsuda	.....	D21/112
D. 295,059	4/1988	Matsuda	.....	D21/112
1,530,637	3/1925	Anderson	.....	273/285
2,717,156	9/1955	Nelson	.....	273/287

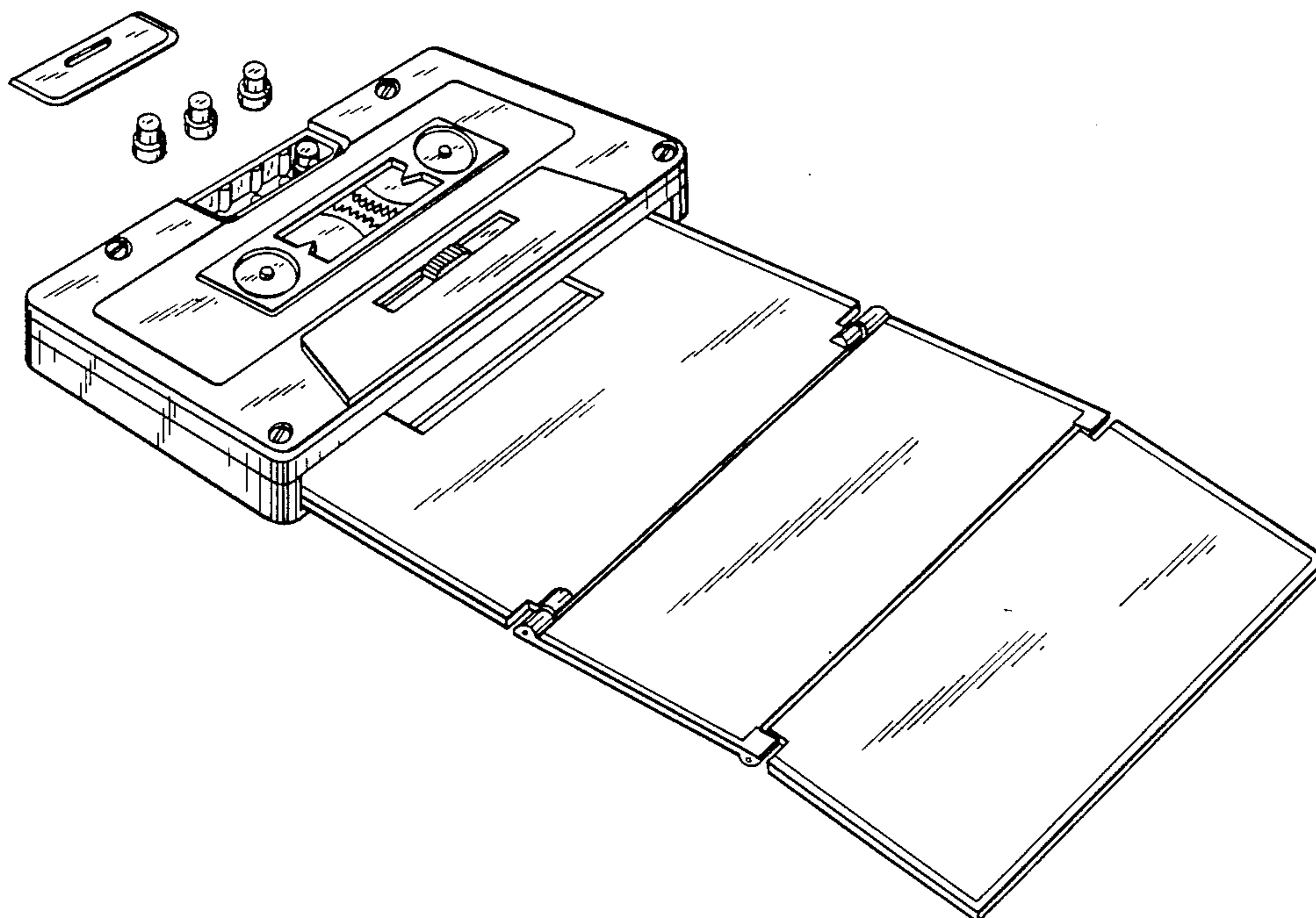

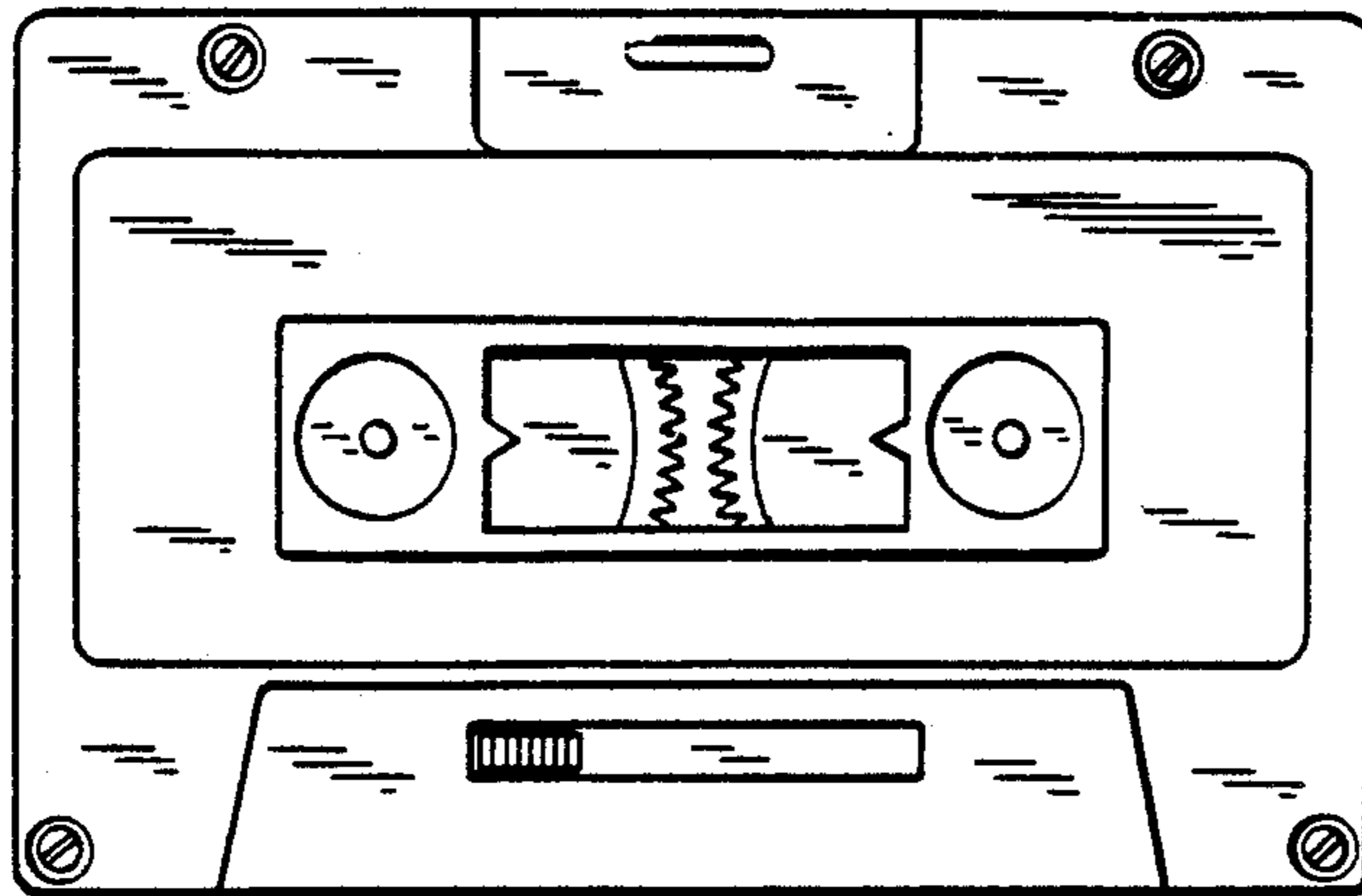

Fig. 1

Fig. 2

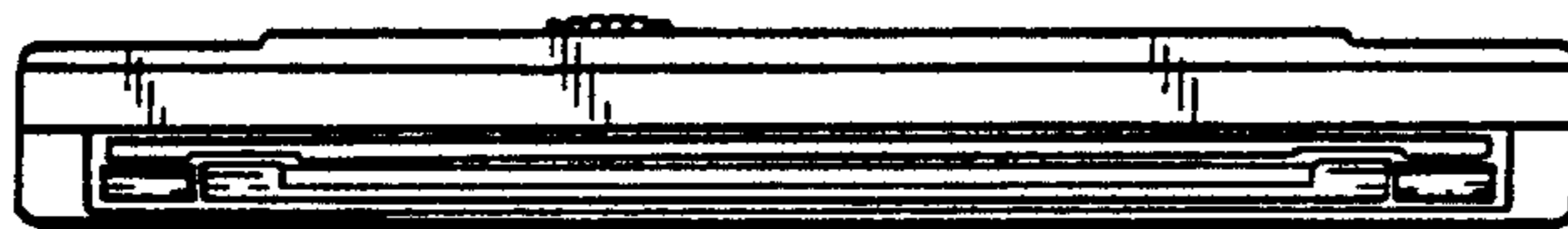
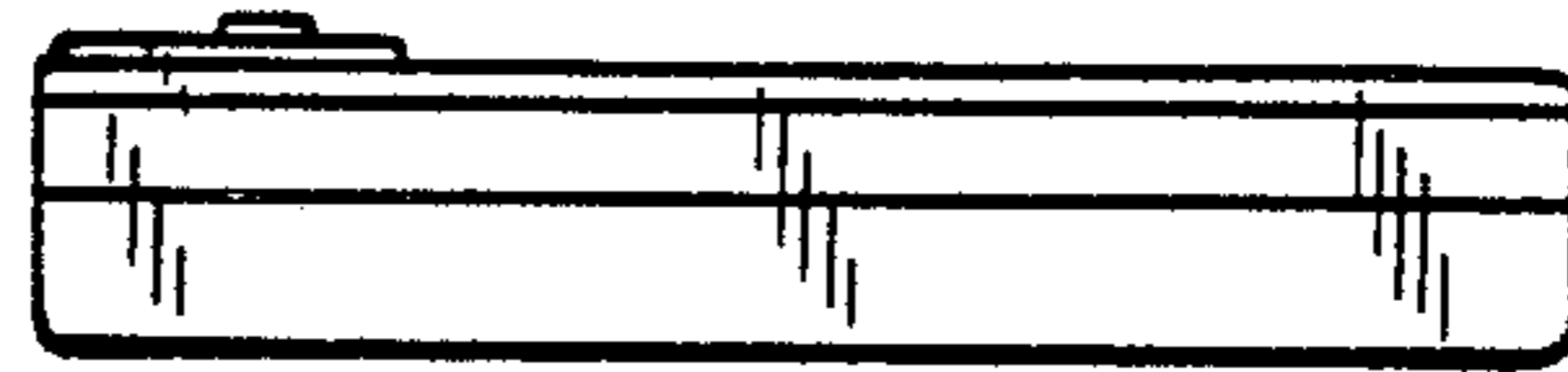

Fig. 3

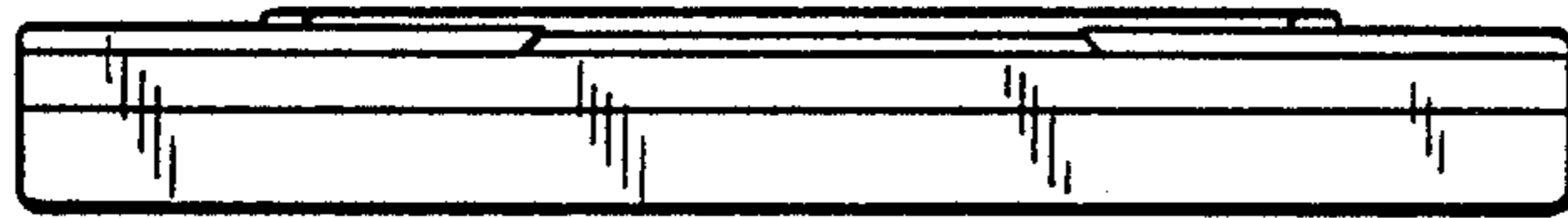

Fig. 4

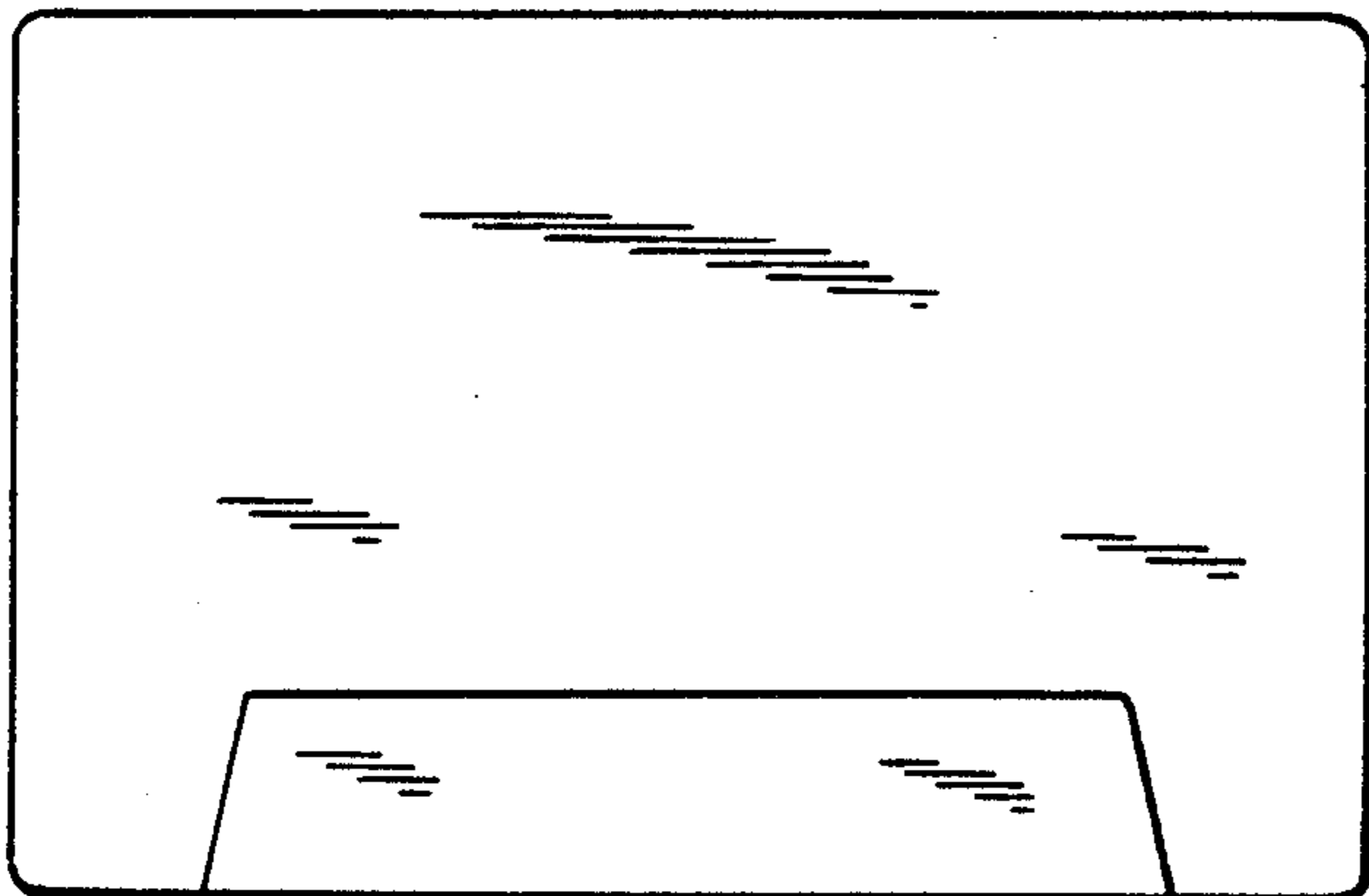
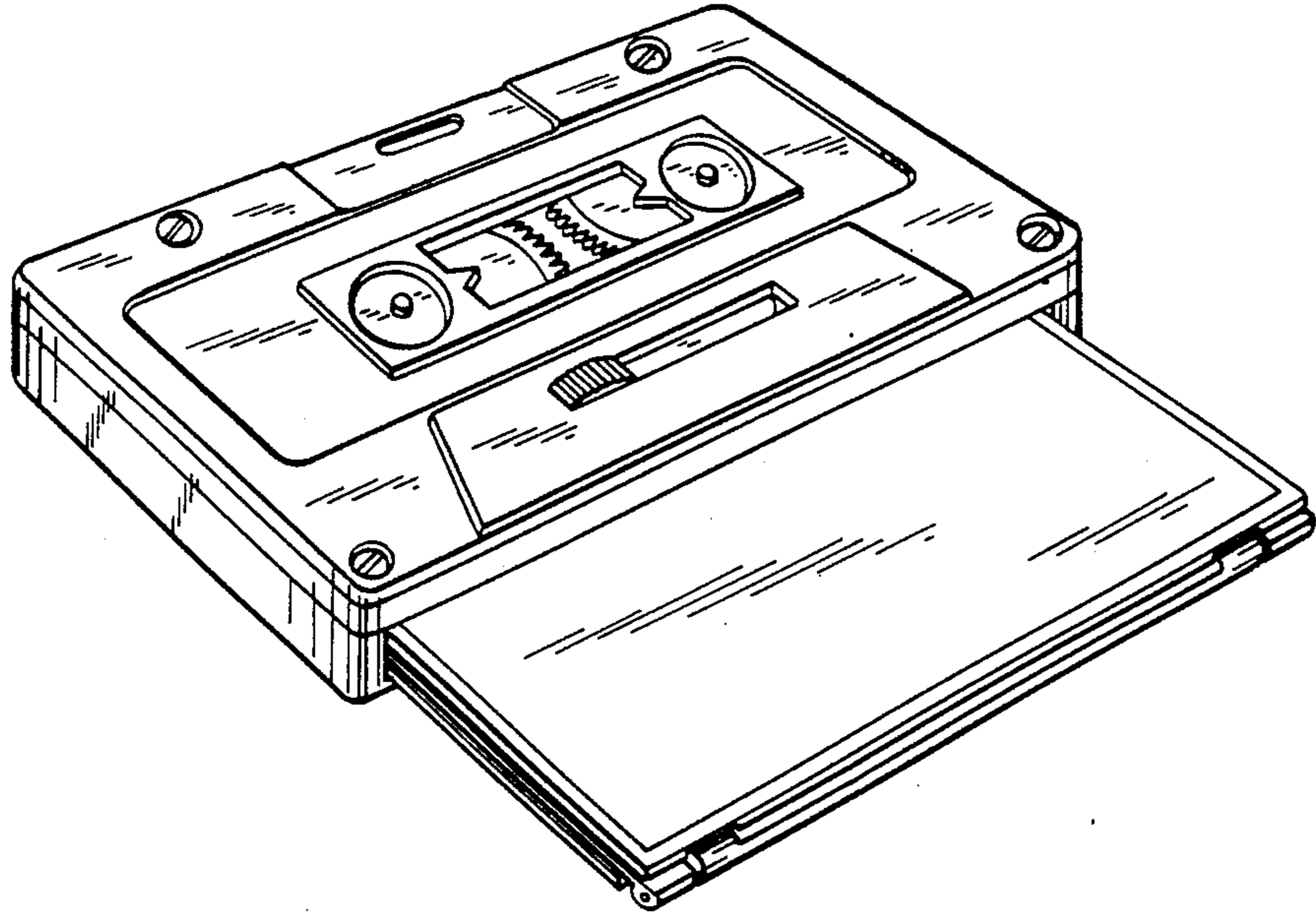

Fig. 5



*Fig. 6*

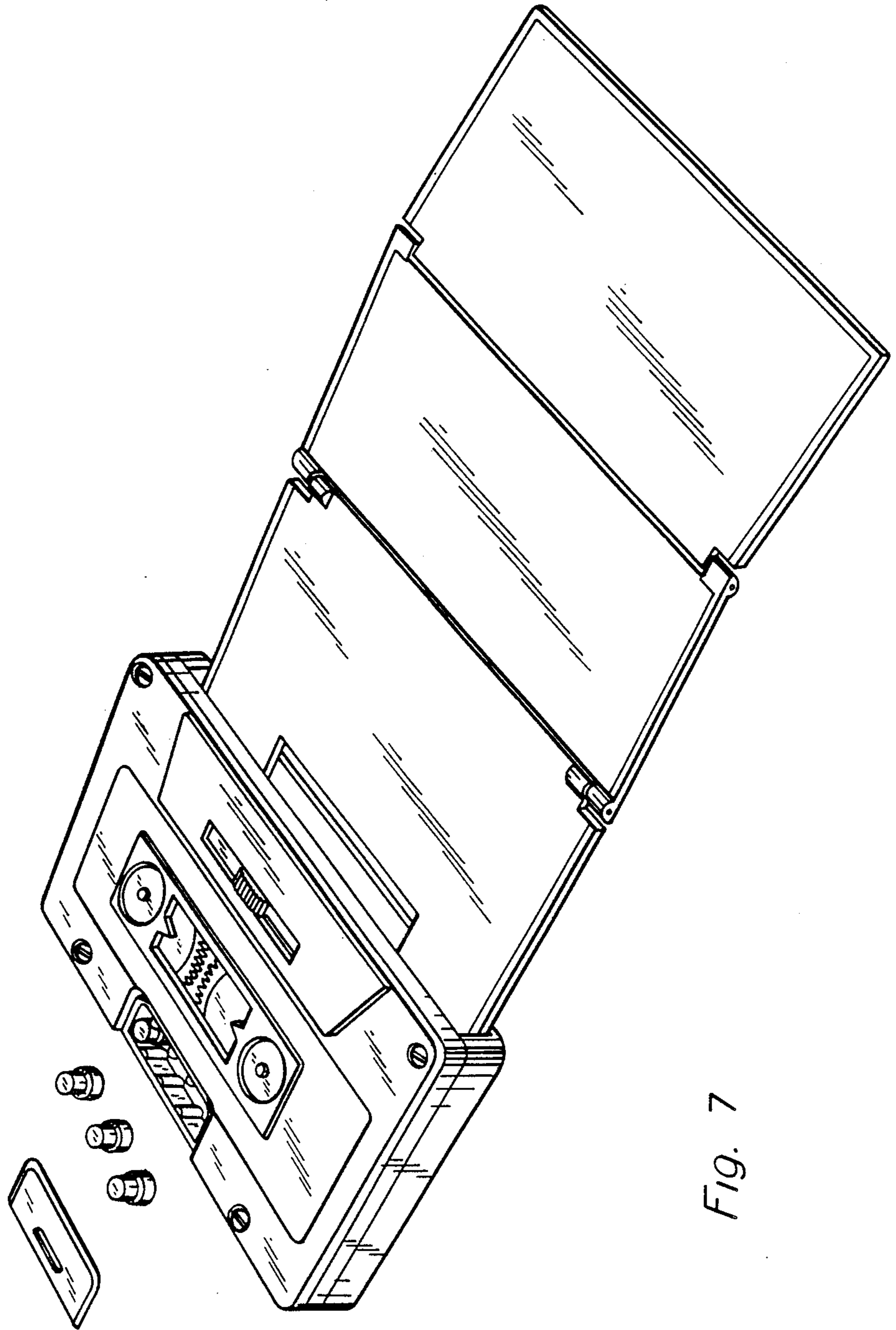

FIG. 7