

[54] MOTOR SCOOTER

[75] Inventors: Masakazu Matsuzawa, San Pedro; Yutaka Kawasaki, Redondo Beach; Jiro Miyata, Rolling Hills Estates; Orrin Shively, Los Angeles, all of Calif.

[73] Assignee: Honda Giken Kogyo Kabushiki Kaisha, Tokyo, Japan

[\*\*] Term: 14 Years

[21] Appl. No.: 155,655

[22] Filed: Feb. 12, 1988

[52] U.S. Cl. .... D12/110

[58] Field of Search ..... D12/110; 180/219

[56] References Cited

U.S. PATENT DOCUMENTS

D. 286,520	11/1986	Kuwuhata et al. ....	D12/110
4,506,754	3/1985	Hirano et al. ....	180/219
4,651,845	3/1987	Yagaski ....	180/219

OTHER PUBLICATIONS

Cycle World Magazine, Dec. 1986, p. 60, Honda Helix Motor Scooter.

Primary Examiner—James M. Gandy  
Assistant Examiner—Melody Brown  
Attorney, Agent, or Firm—Lyon & Lyon

[57] CLAIM

The ornamental design for a motor scooter, as shown and described.

DESCRIPTION

FIG. 1 is a perspective view of a motor scooter showing our new design;  
FIG. 2 is a right side elevation view thereof;  
FIG. 3 is a top plan view thereof;  
FIG. 4 is a left side elevational view thereof;  
FIG. 5 is a front elevational view thereof; and  
FIG. 6 is a rear elevational view thereof;  
FIG. 7 is a perspective view of a second embodiment of a motor scooter showing our new design;  
FIG. 8 is a right side elevation view of FIG. 7;  
FIG. 9 is a top plan view of FIG. 7;  
FIG. 10 is a left side elevation view of FIG. 7;  
FIG. 11 is a front elevational view of FIG. 7; and  
FIG. 12 is a rear elevation view of FIG. 7.

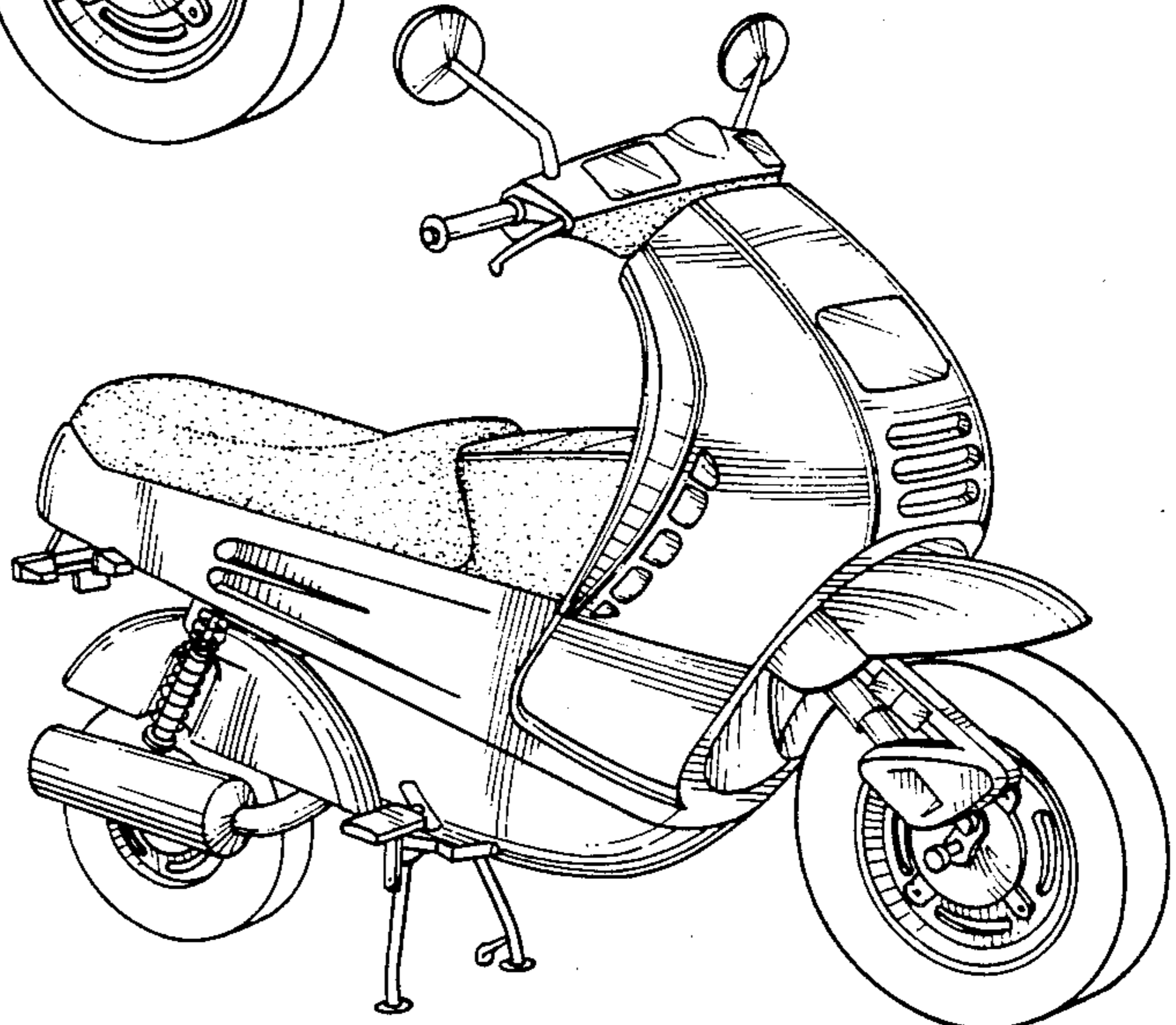
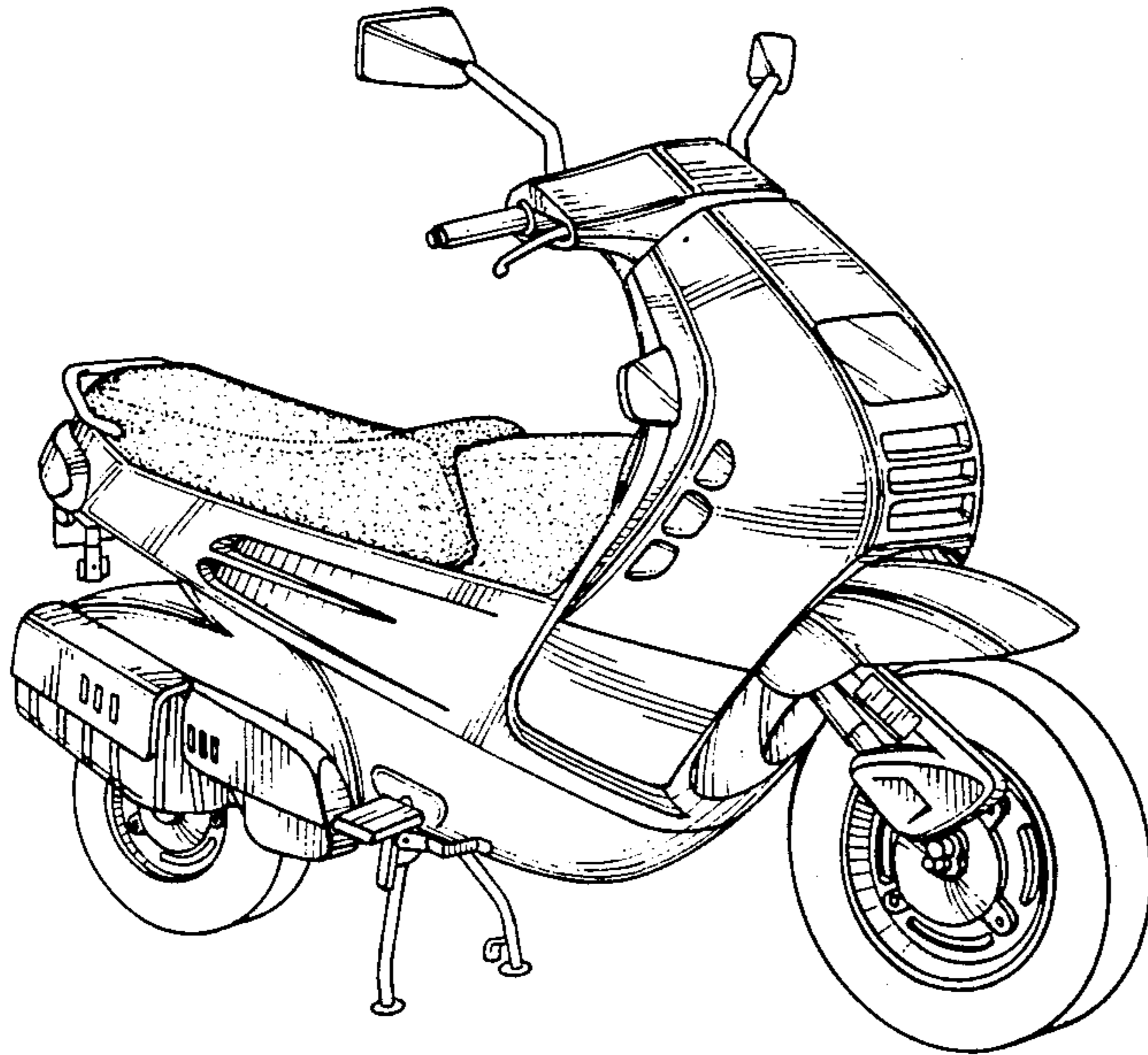

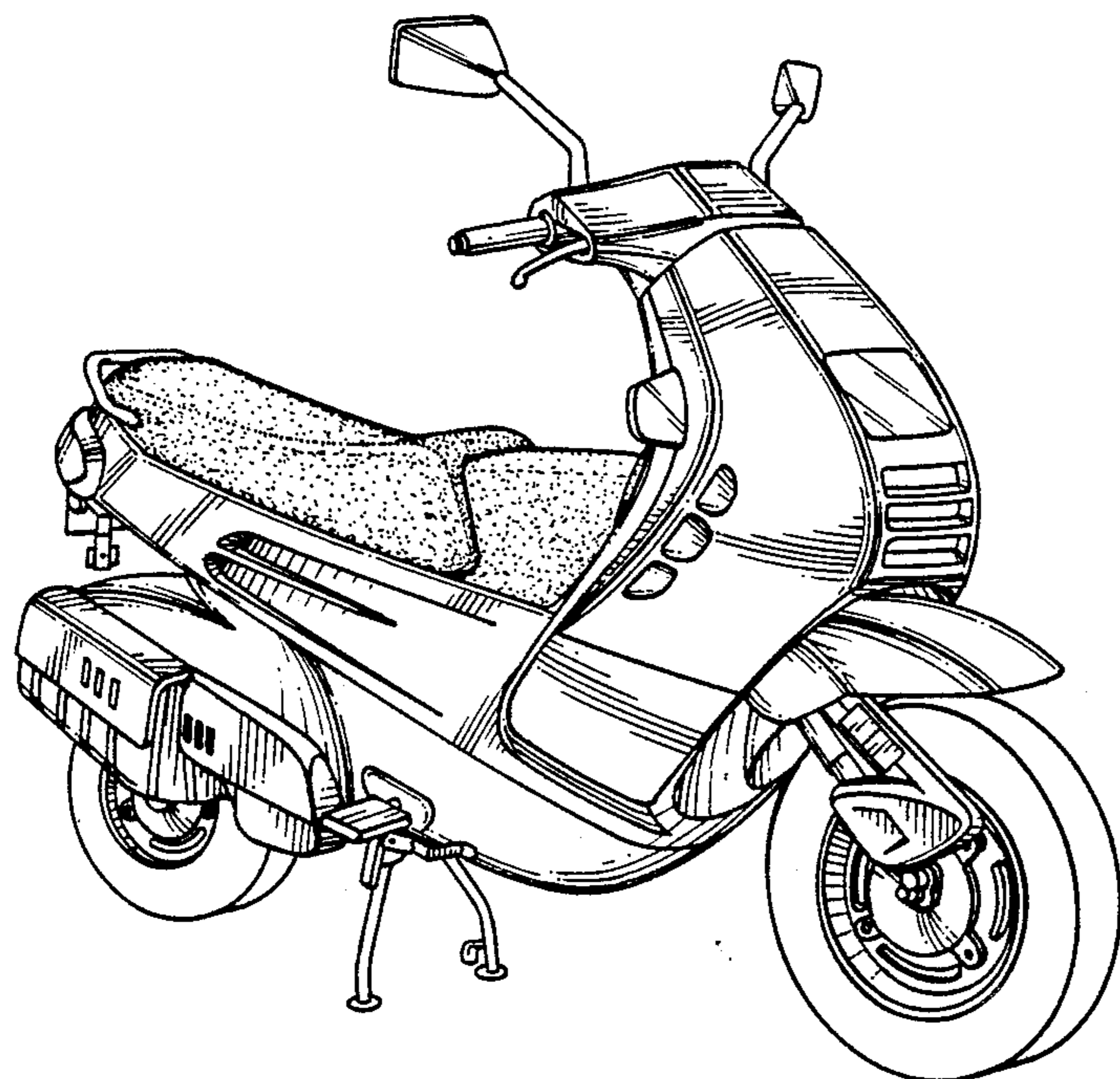

FIG. 1.

FIG. 2.

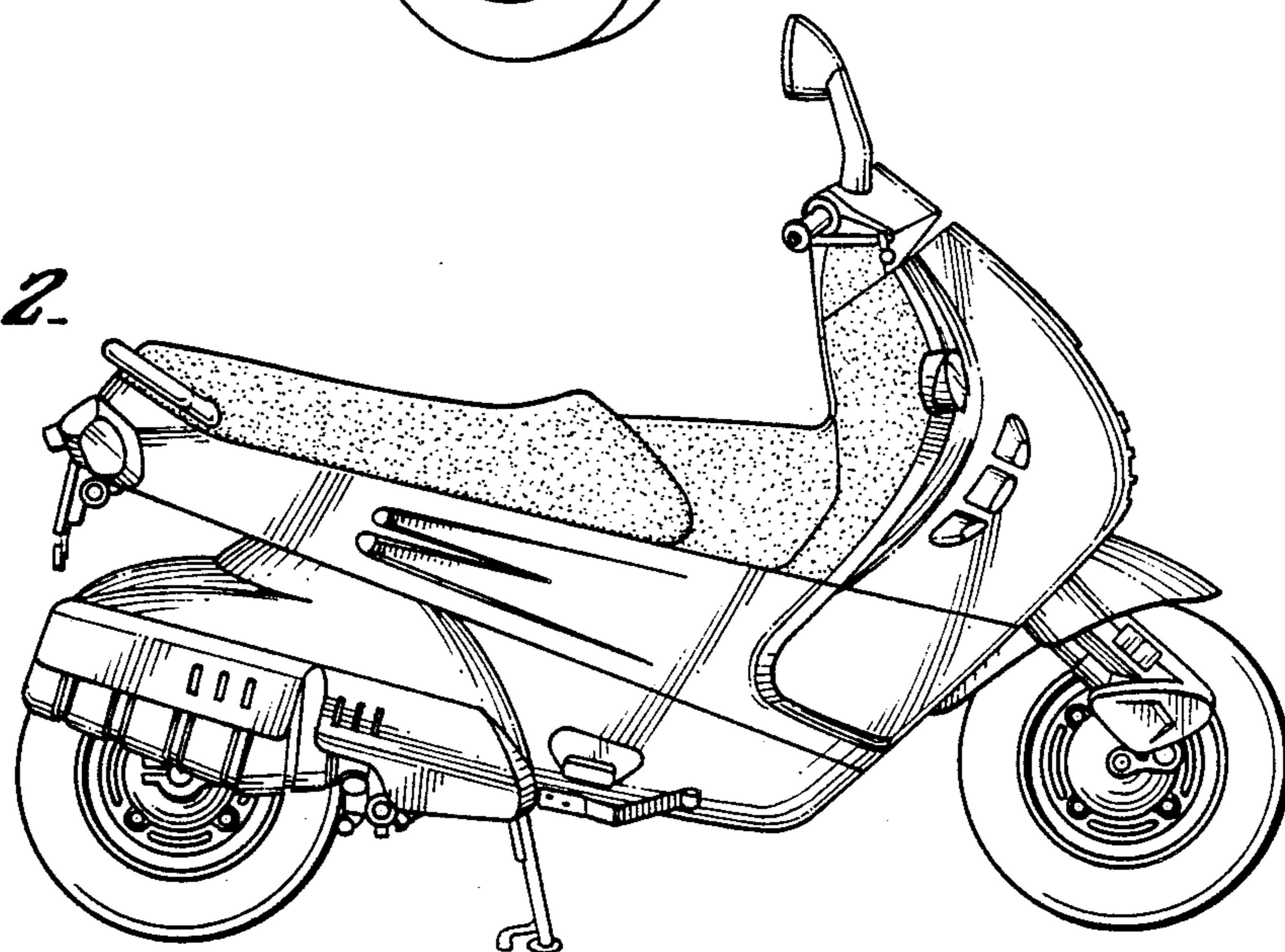
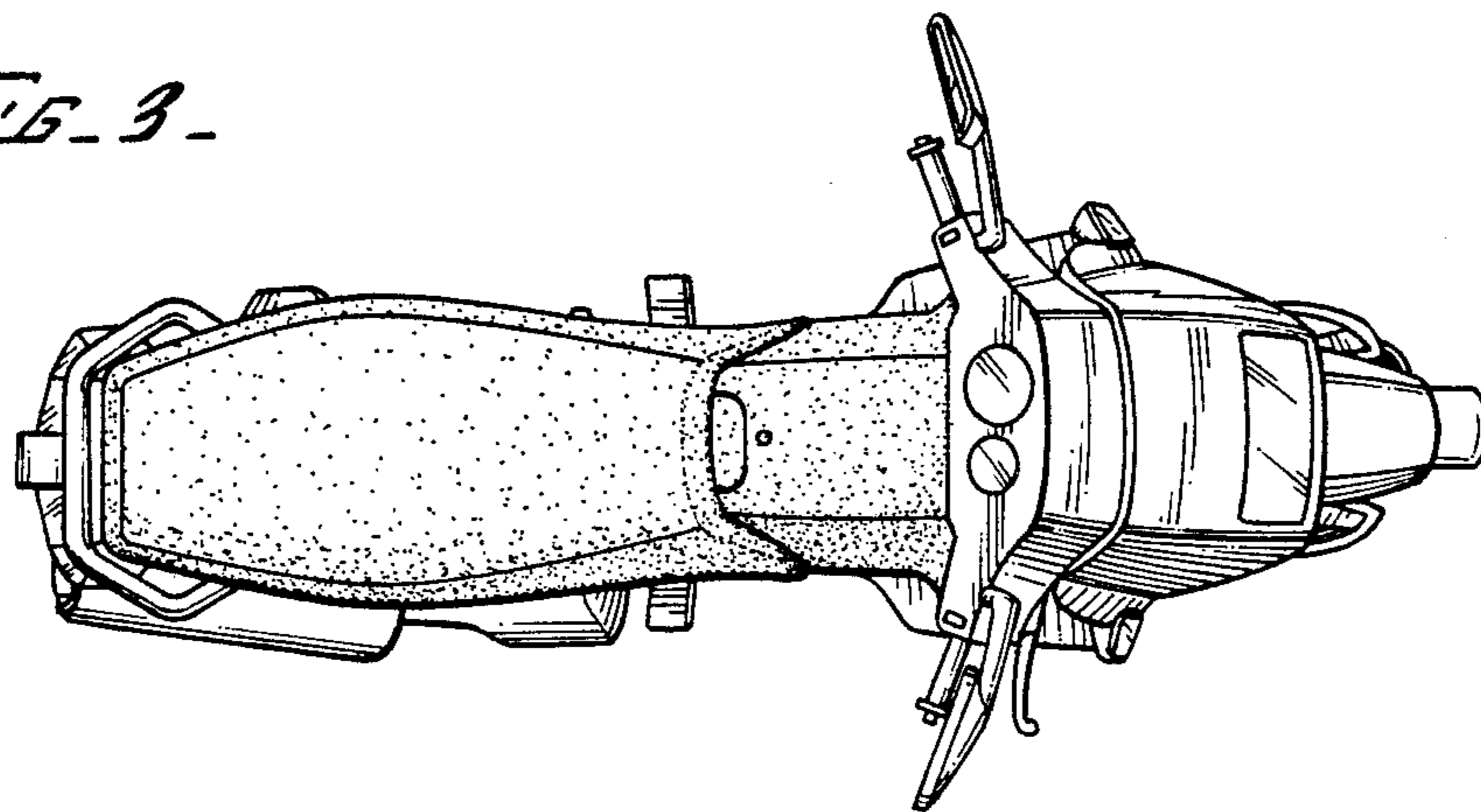

FIG. 3.





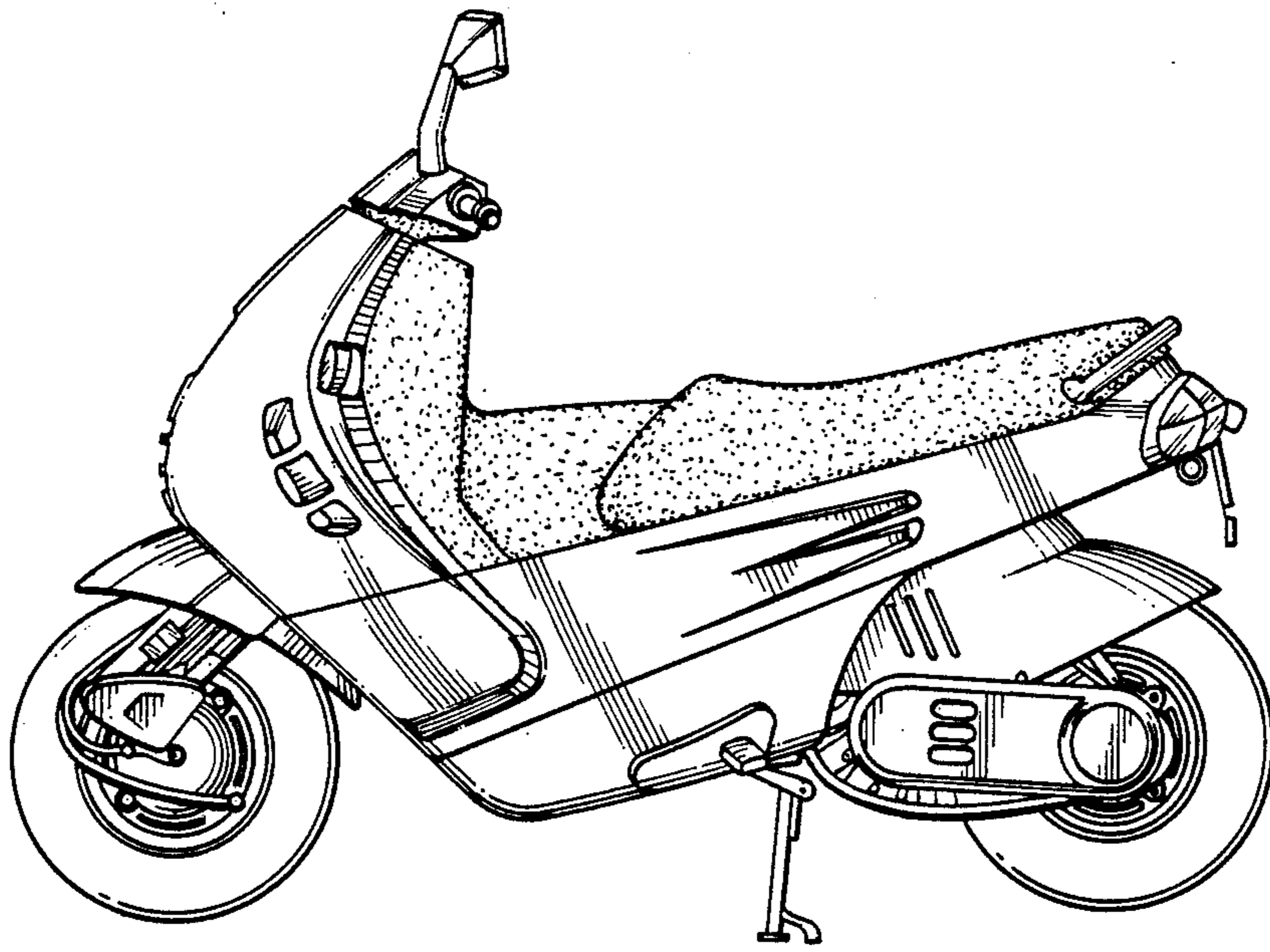

FIG. 4.

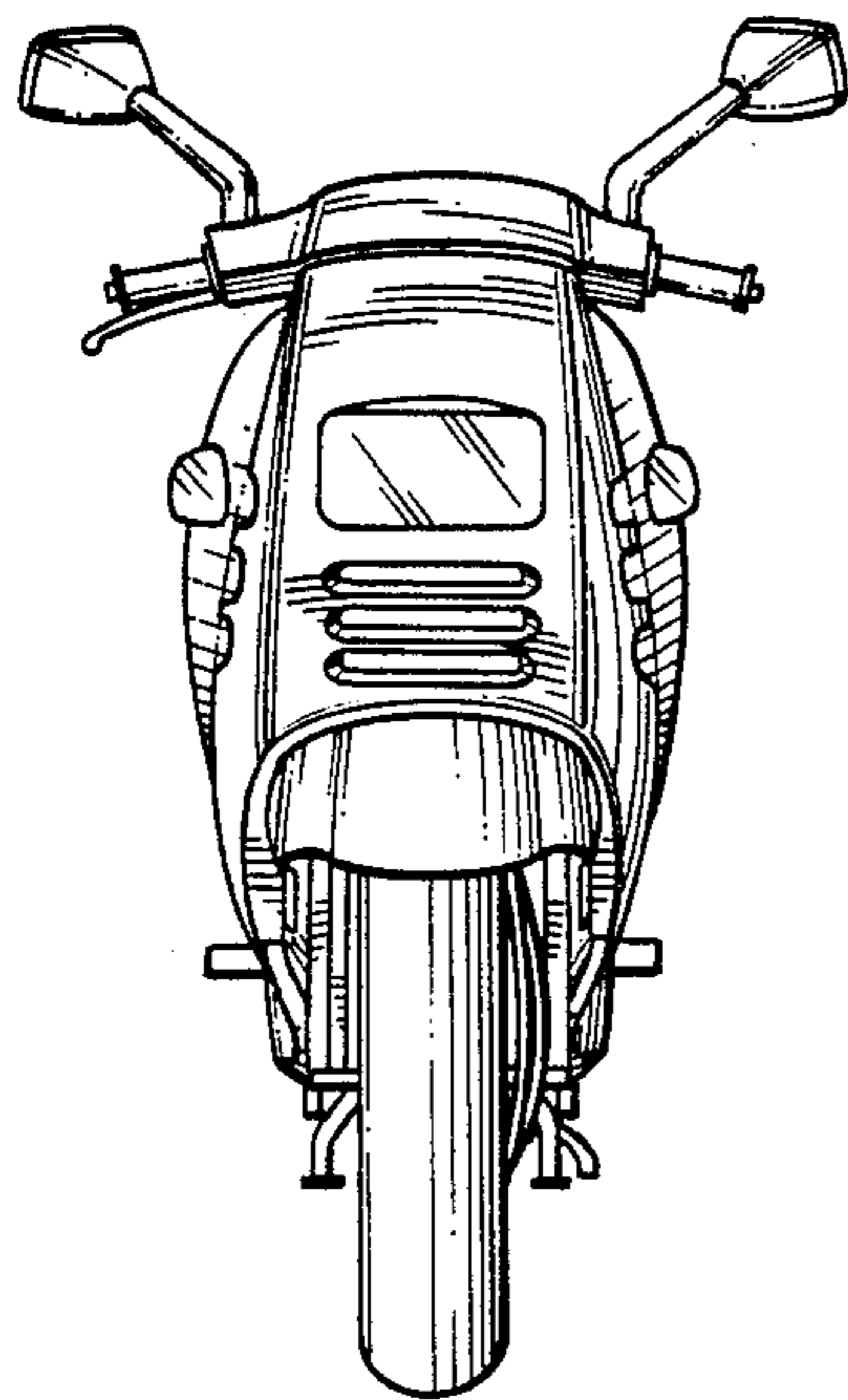

FIG. 5.

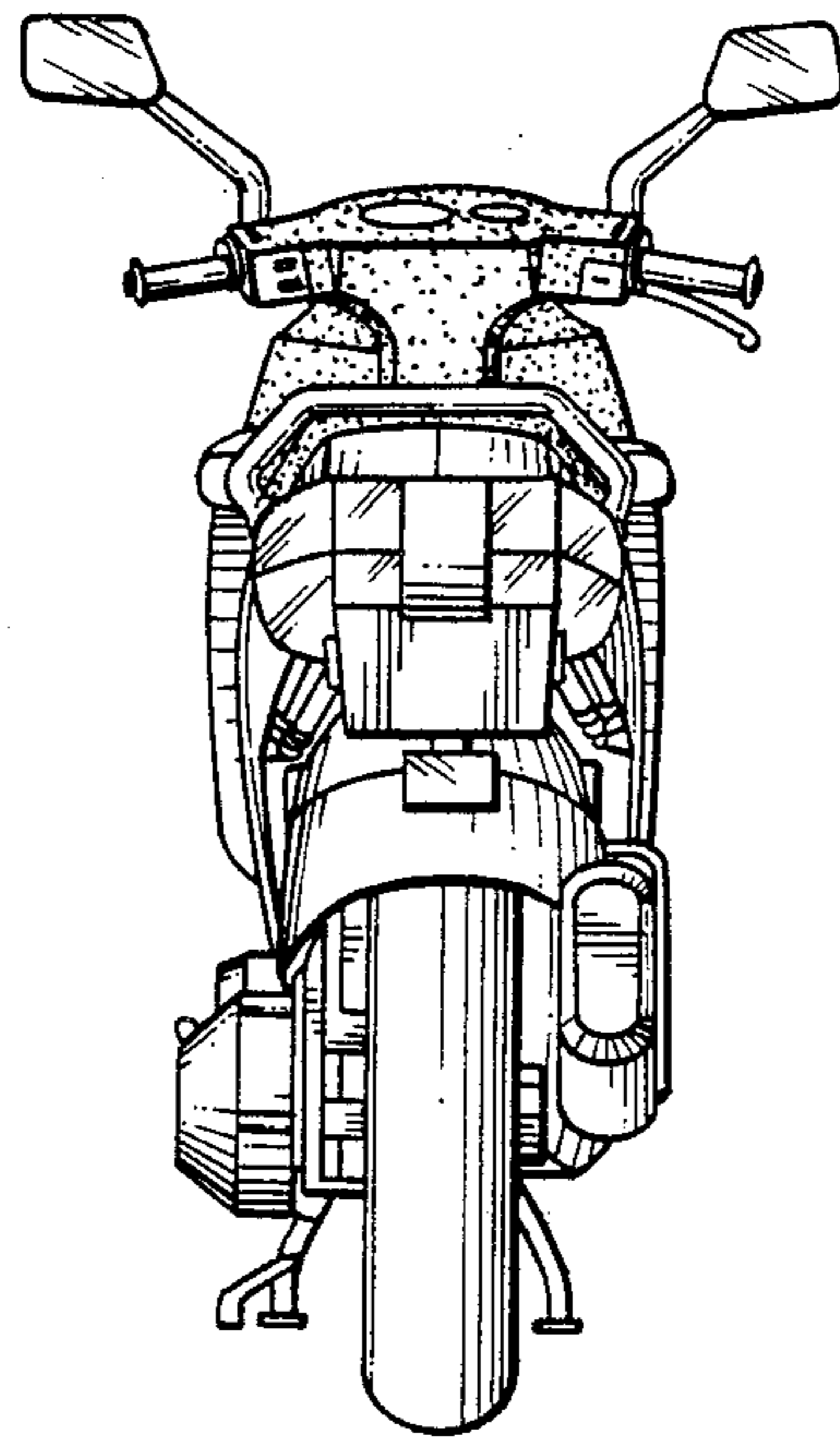

FIG. 6.

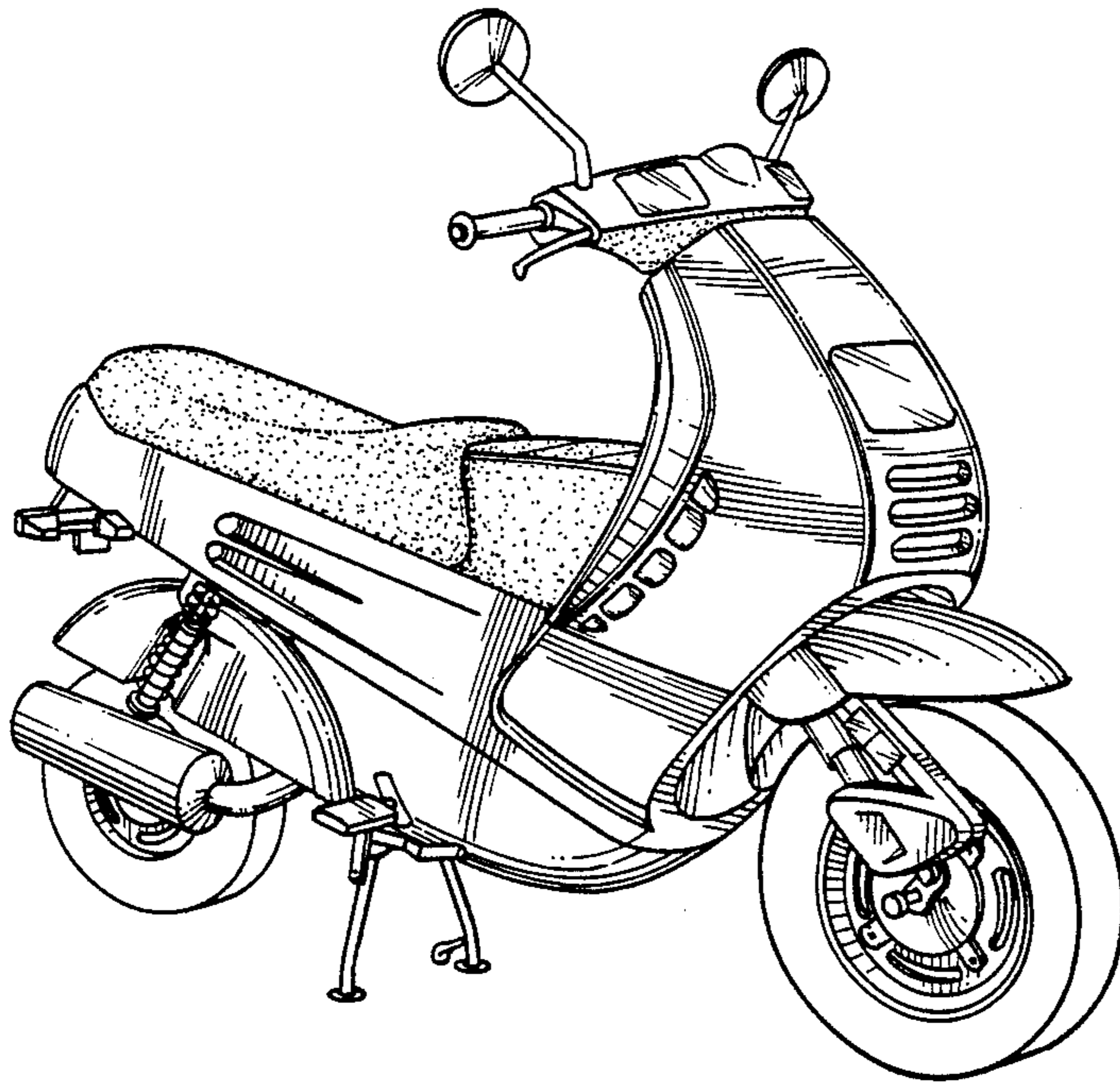

FIG. 1.

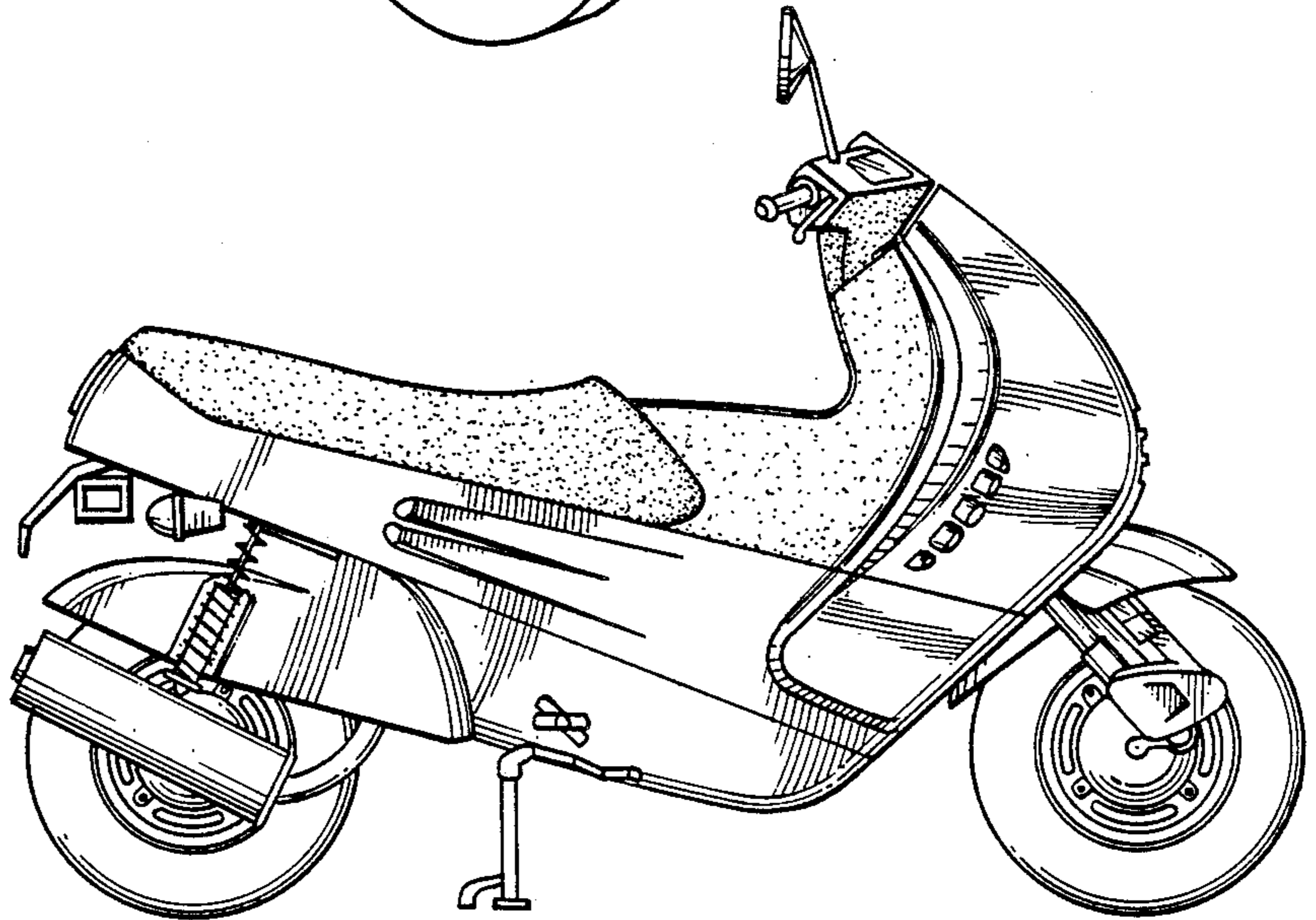

FIG. 8.

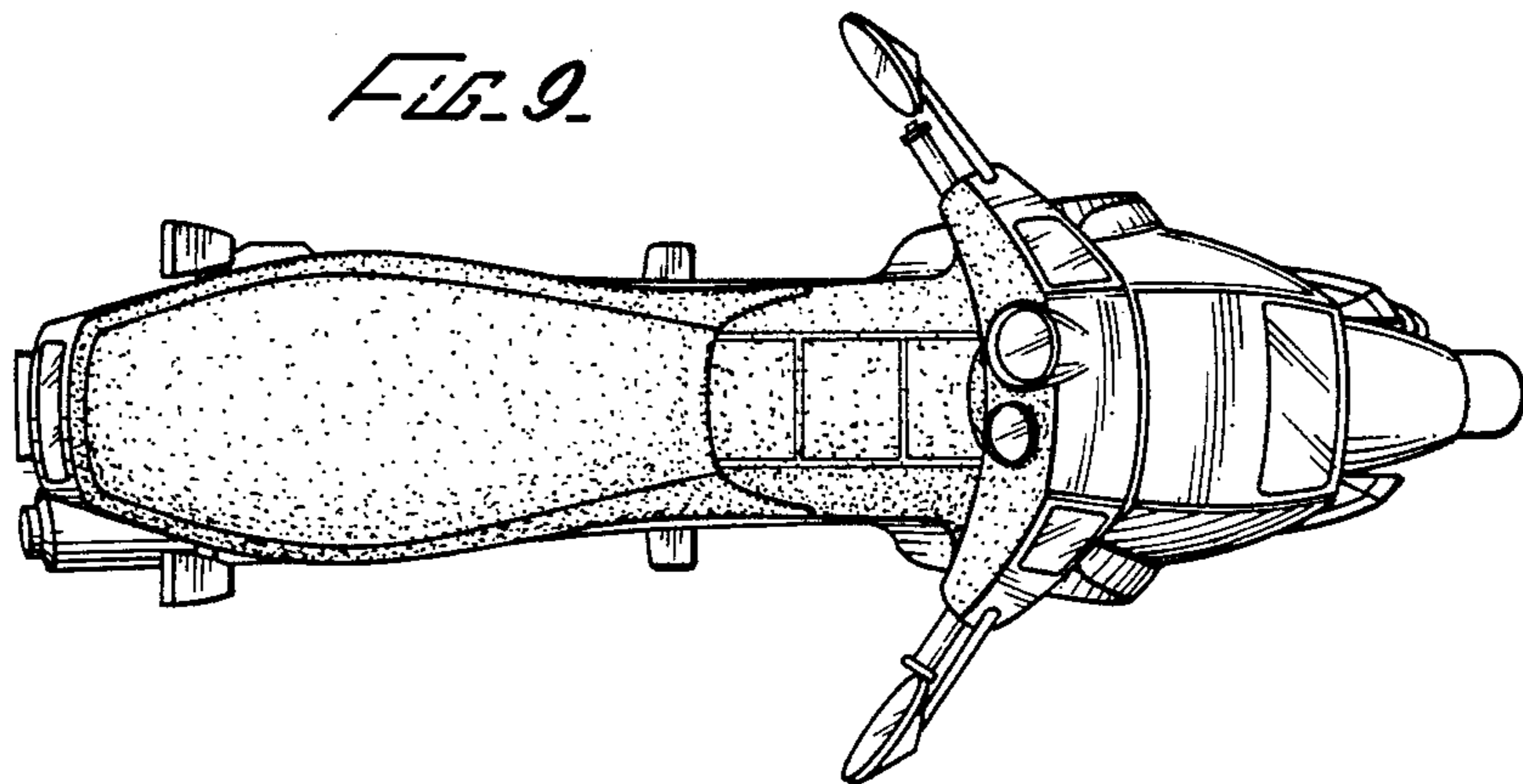
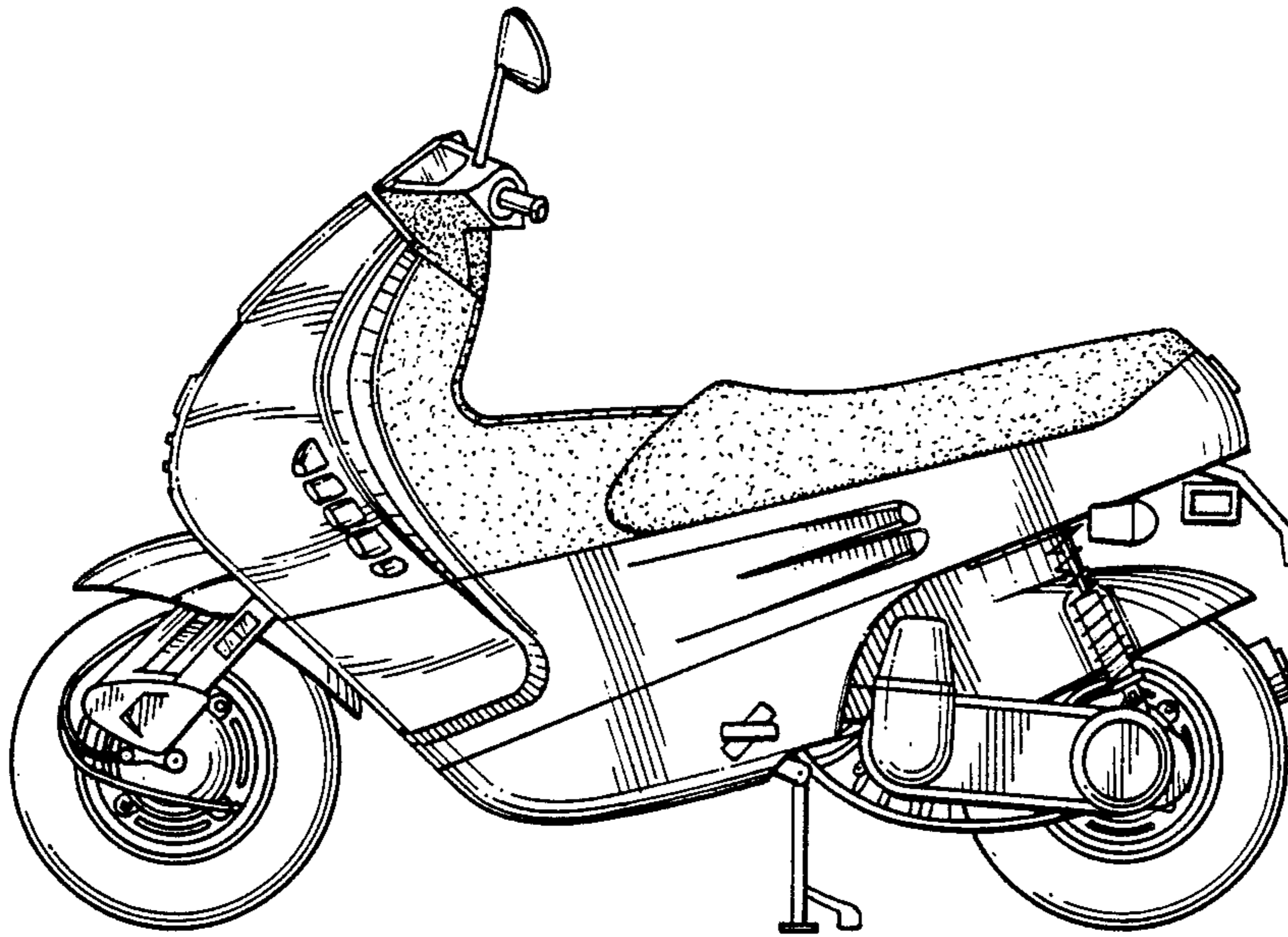
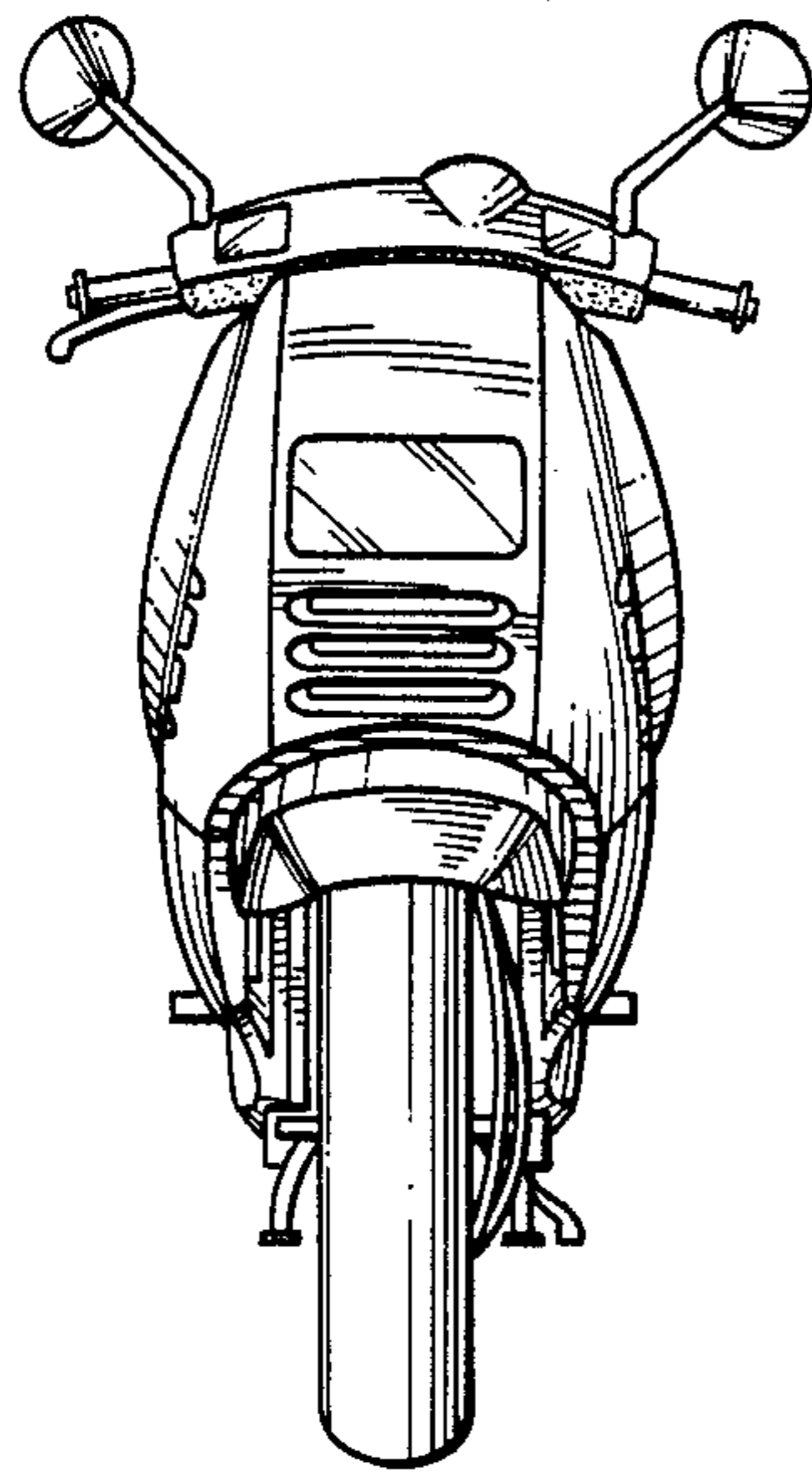

FIG. 9.

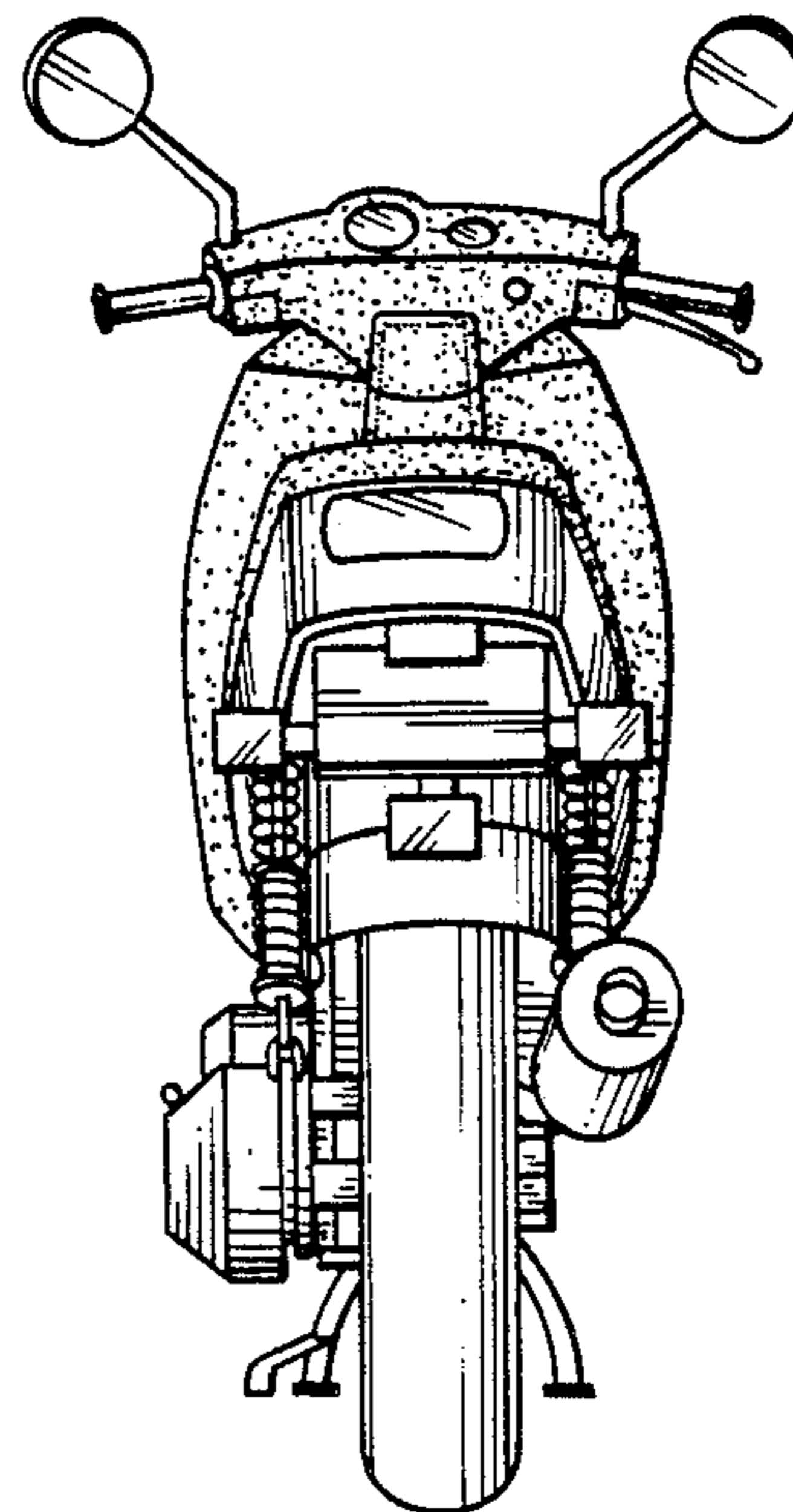



*FIG. 10.*



*FIG. 11.*



*FIG. 12.*