

# United States Patent [19]

Smith et al.

[11] Patent Number: Des. 312,004

[45] Date of Patent: \*\* Nov. 13, 1990

[54] FOLDABLE SEAT

[75] Inventors: Larry D. Smith, Oak Grove; Robert G. Tanner, St. Charles, both of Mo.

[73] Assignee: Action Products Co., Inc., Odessa, Mo.

[\*\*] Term: 14 Years

[21] Appl. No.: 59,321

[22] Filed: Jun. 8, 1987

[52] U.S. Cl. .... D6/368

[58] Field of Search ..... D6/335, 336, 368, 502;  
D3/30.1, 32, 78

[56] References Cited

U.S. PATENT DOCUMENTS

D. 197,558 2/1964 Sokolis ..... D6/368  
D. 252,658 8/1979 Kressin ..... D6/368  
D. 290,797 7/1987 Hartt ..... D6/502

D. 298,186 10/1988 Brannon ..... D6/336  
D. 301,191 5/1989 Anello et al. .... D6/502  
D. 303,878 10/1989 Goldsmith ..... D6/502

*Primary Examiner*—Bruce W. Dunkins

*Assistant Examiner*—Ann Hunt

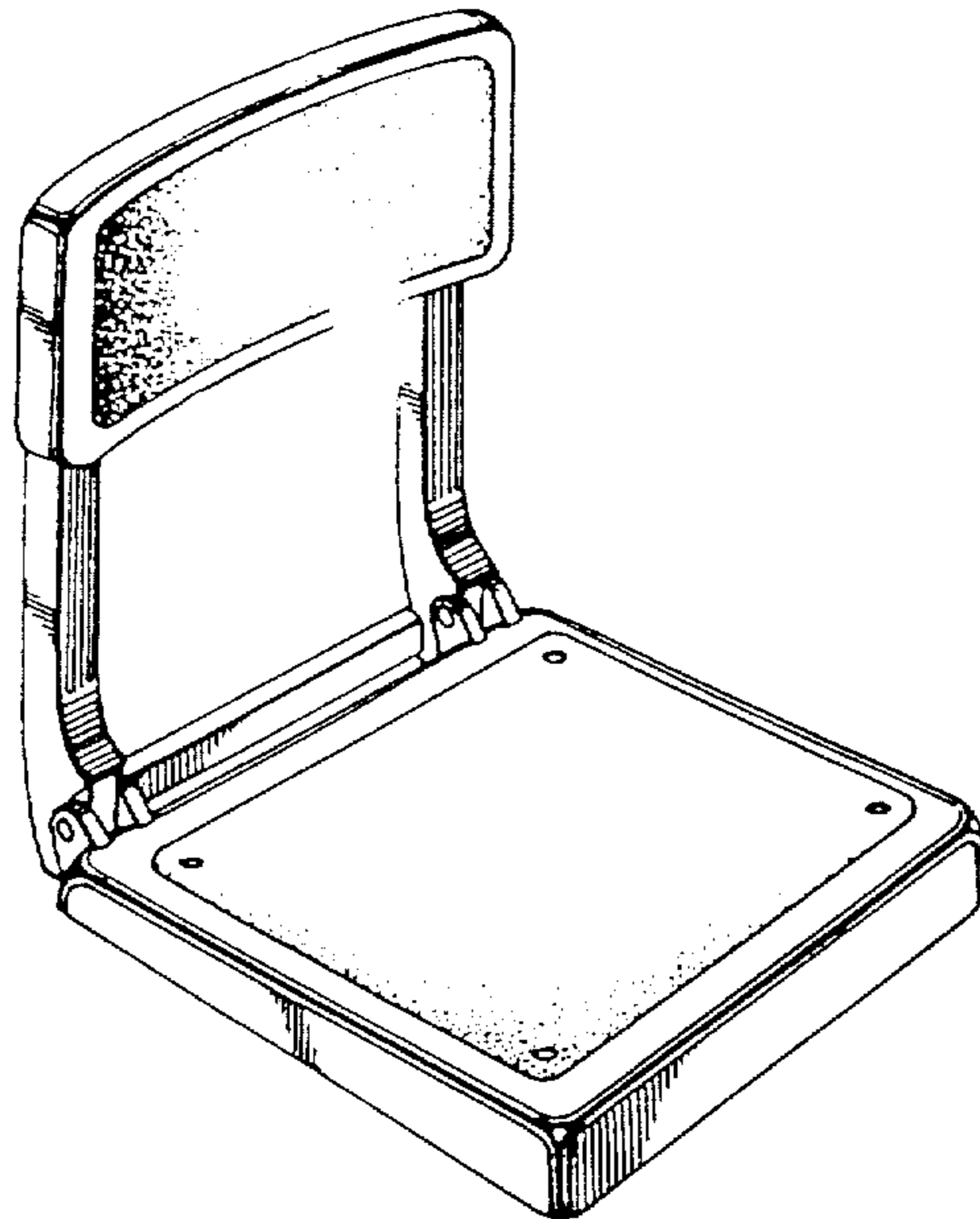
*Attorney, Agent, or Firm*—Hovey, Williams, Timmons & Collins

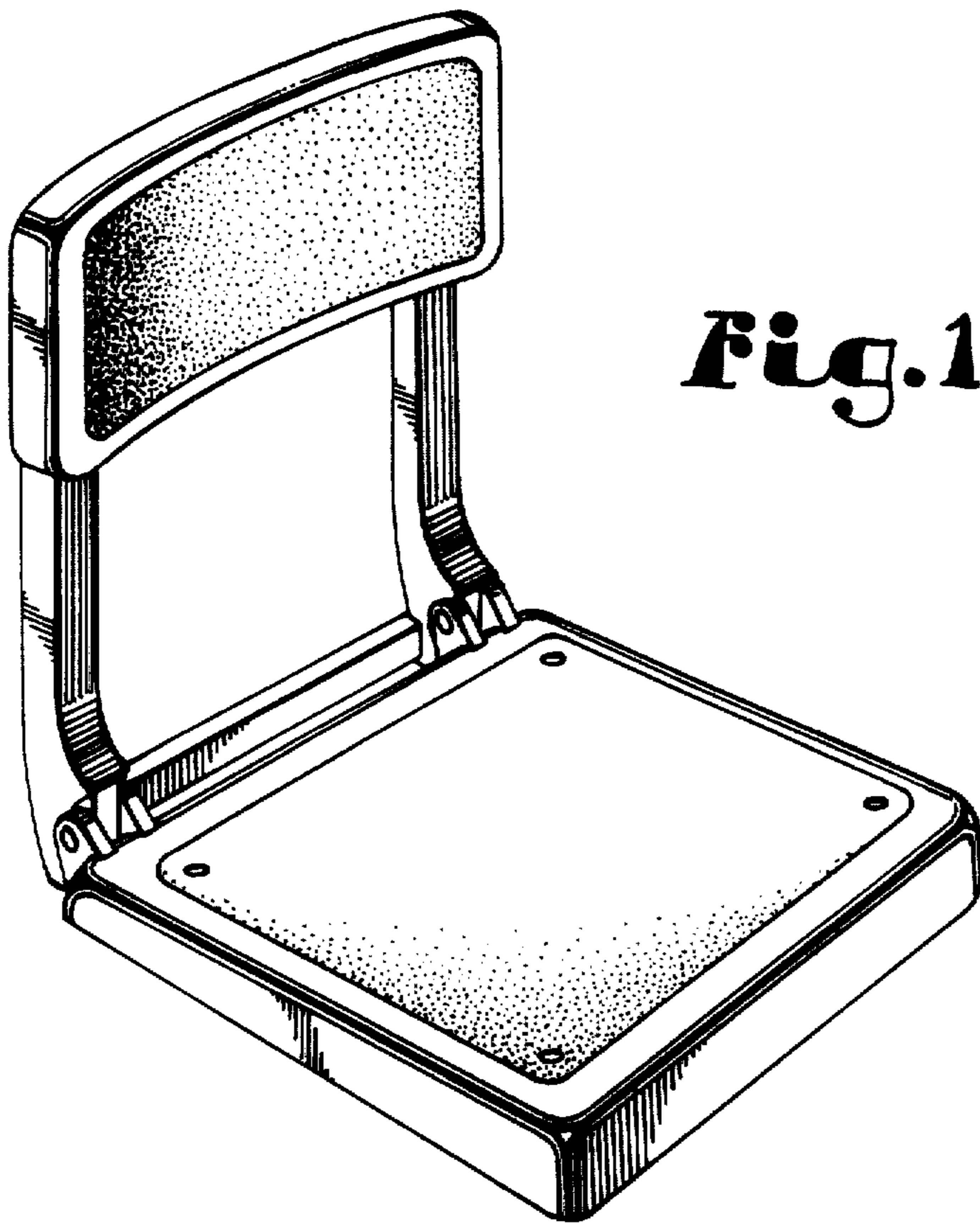
[57] CLAIM

The ornamental design for a foldable seat, as shown and described.

DESCRIPTION

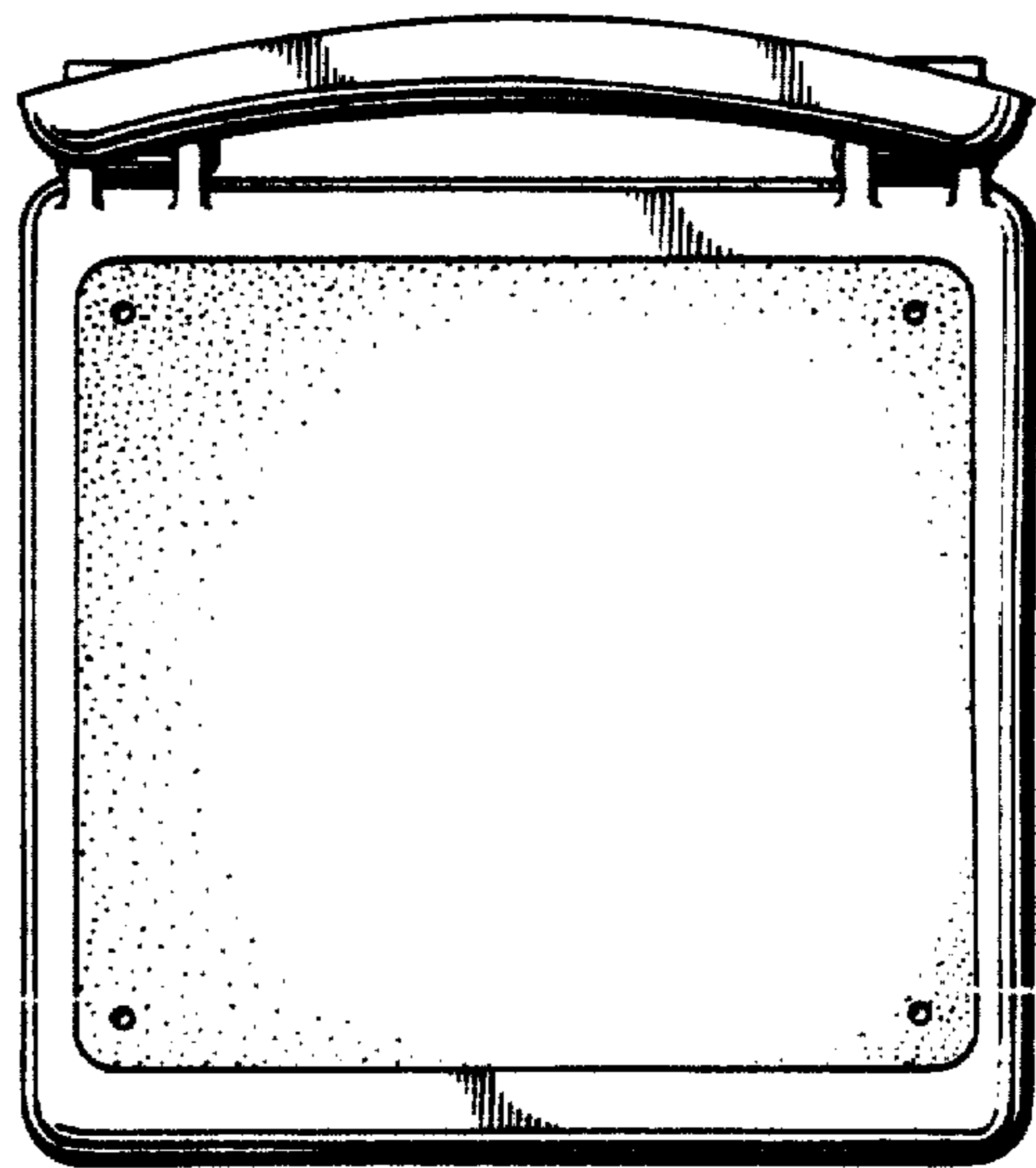
FIG. 1 is a front perspective view of the foldable seat showing our new design;  
FIG. 2 is a top plan view;  
FIG. 3 is a side elevational view;  
FIG. 4 is a front elevational view;  
FIG. 5 is a bottom plan view; and  
FIG. 6 is a rear elevational view thereof.



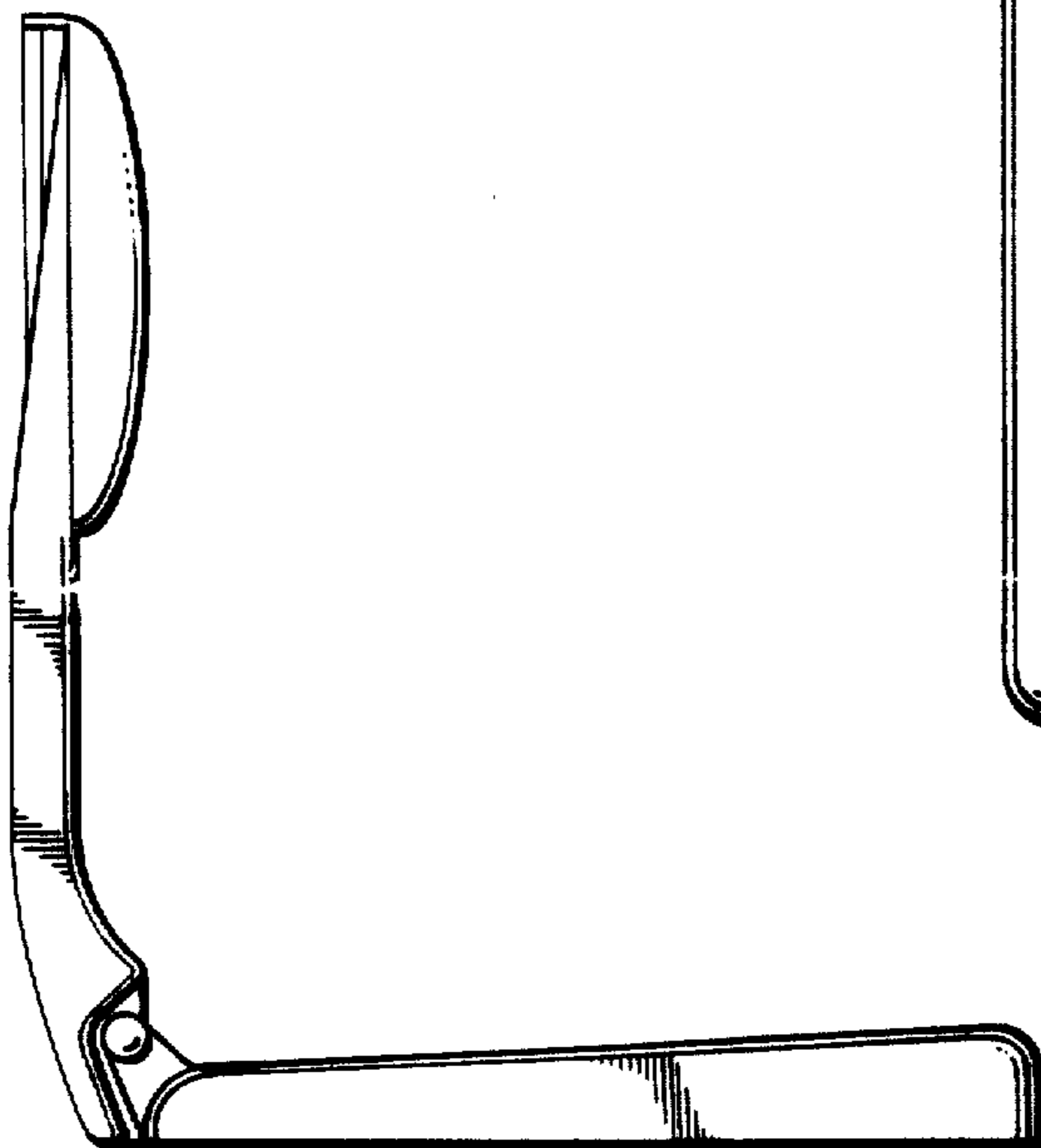


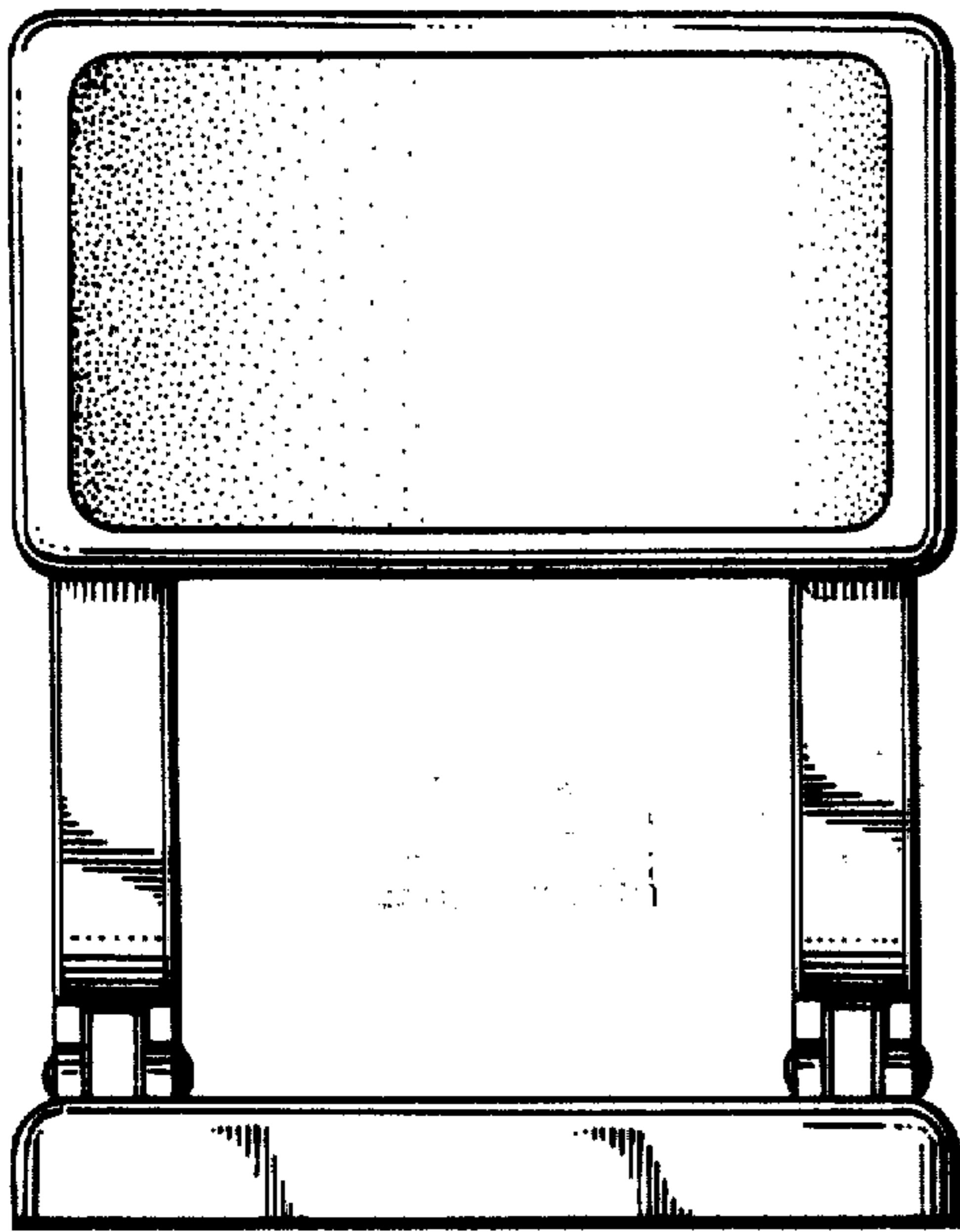
**Fig. 1.**

**Fig. 2.**



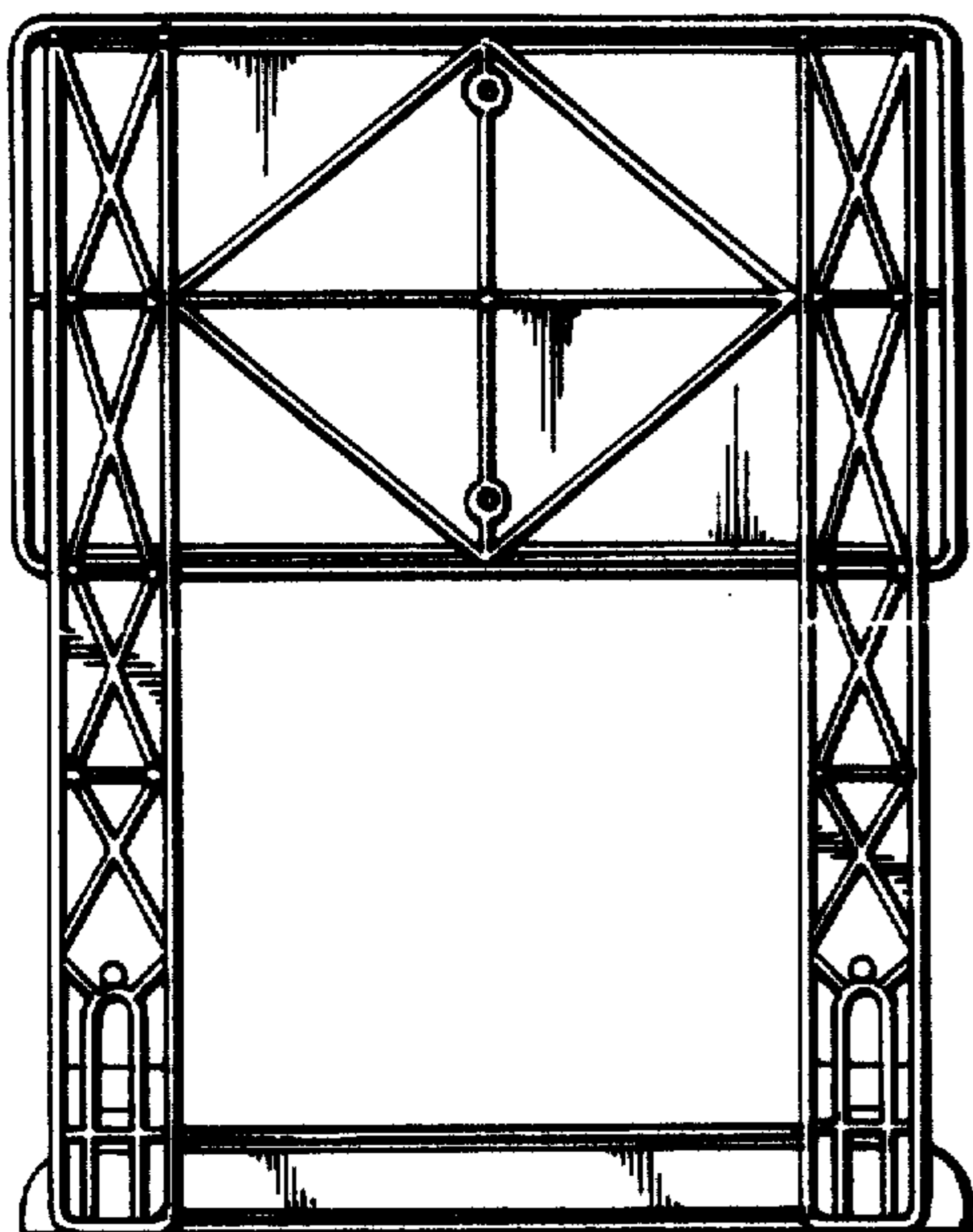
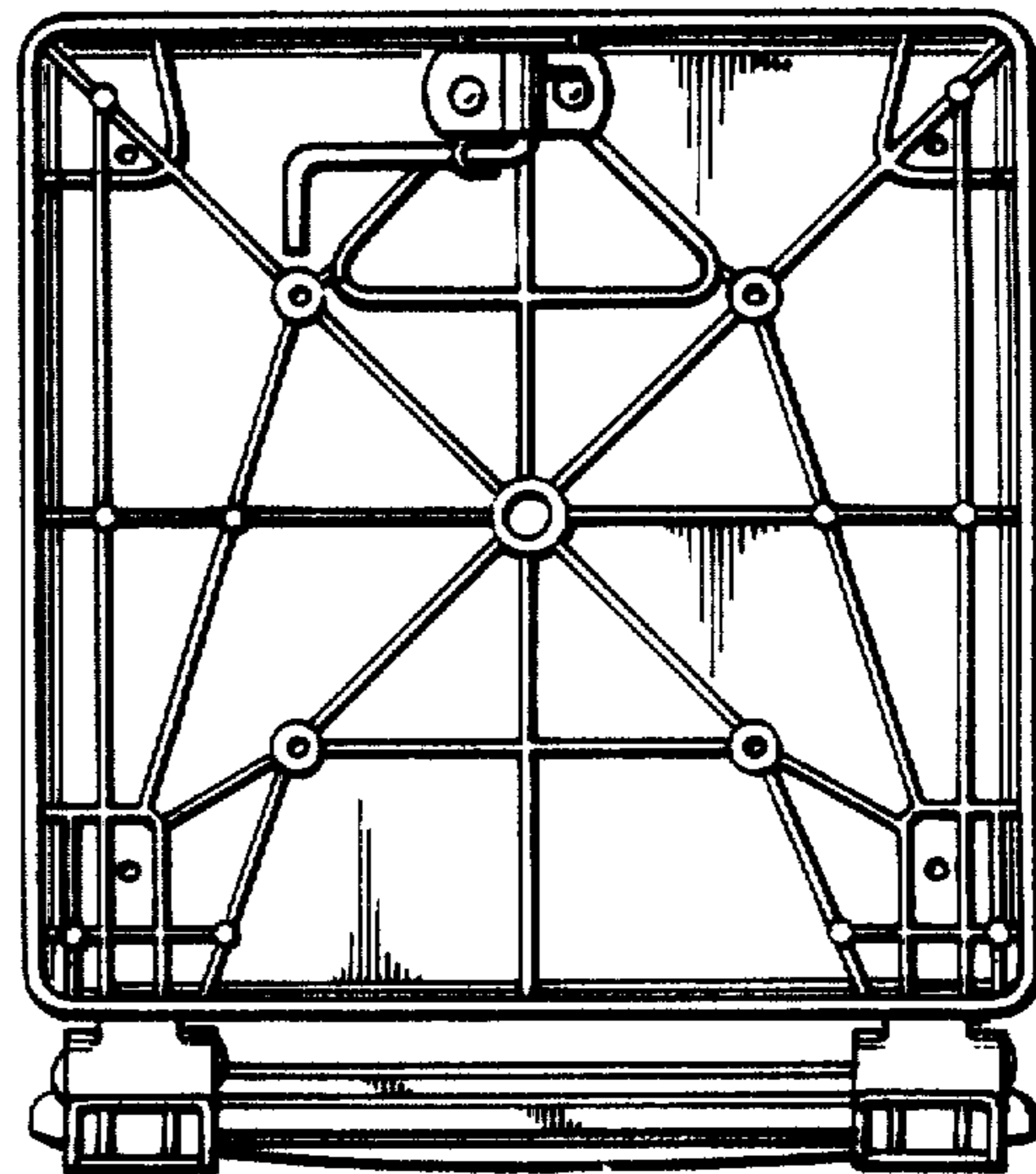
**Fig. 3.**





*Fig. 4.*

*Fig. 5.*



*Fig. 6.*