

United States Patent [19]

McGrail et al.

[11] Patent Number: **Des. 311,965**

[45] Date of Patent: **** Nov. 6, 1990**

[54] **ELECTRIC LANTERN**

[75] Inventors: **Peter McGrail; Grace McGrail**, both of Bury; **Geoffrey A. Williams**, Castleton, all of England

[73] Assignee: **Topline Leisure Limited**, Dukenfield, England

[**] Term: **14 Years**

[21] Appl. No.: **280,649**

[22] Filed: **Dec. 5, 1988**

[30] **Foreign Application Priority Data**

Jun. 3, 1988 [GB] United Kingdom 1051201

[52] U.S. Cl. **D26/48**

[58] Field of Search **D26/37-50;**
362/157, 158, 191-208, 183-190

[56] **References Cited**

U.S. PATENT DOCUMENTS

D. 287,293	12/1986	Wang	D26/38
D. 294,643	3/1988	Ariba	D26/48
3,252,733	5/1966	Moore et al.	362/157
4,321,657	3/1982	Hoi	362/183

Primary Examiner—Susan J. Lucas
Assistant Examiner—M. H. Tung
Attorney, Agent, or Firm—Mason, Fenwick & Lawrence

[57] **CLAIM**

The ornamental design for an electric lantern, as shown and described.

DESCRIPTION

FIG. 1 is a side elevational view of an electric lantern showing our new design, the left side being a mirror image;

FIG. 2 is a front elevational view thereof;

FIG. 3 is a rear elevational view thereof;

FIG. 4 is a top plan view thereof; and

FIG. 5 is a bottom plan view thereof.

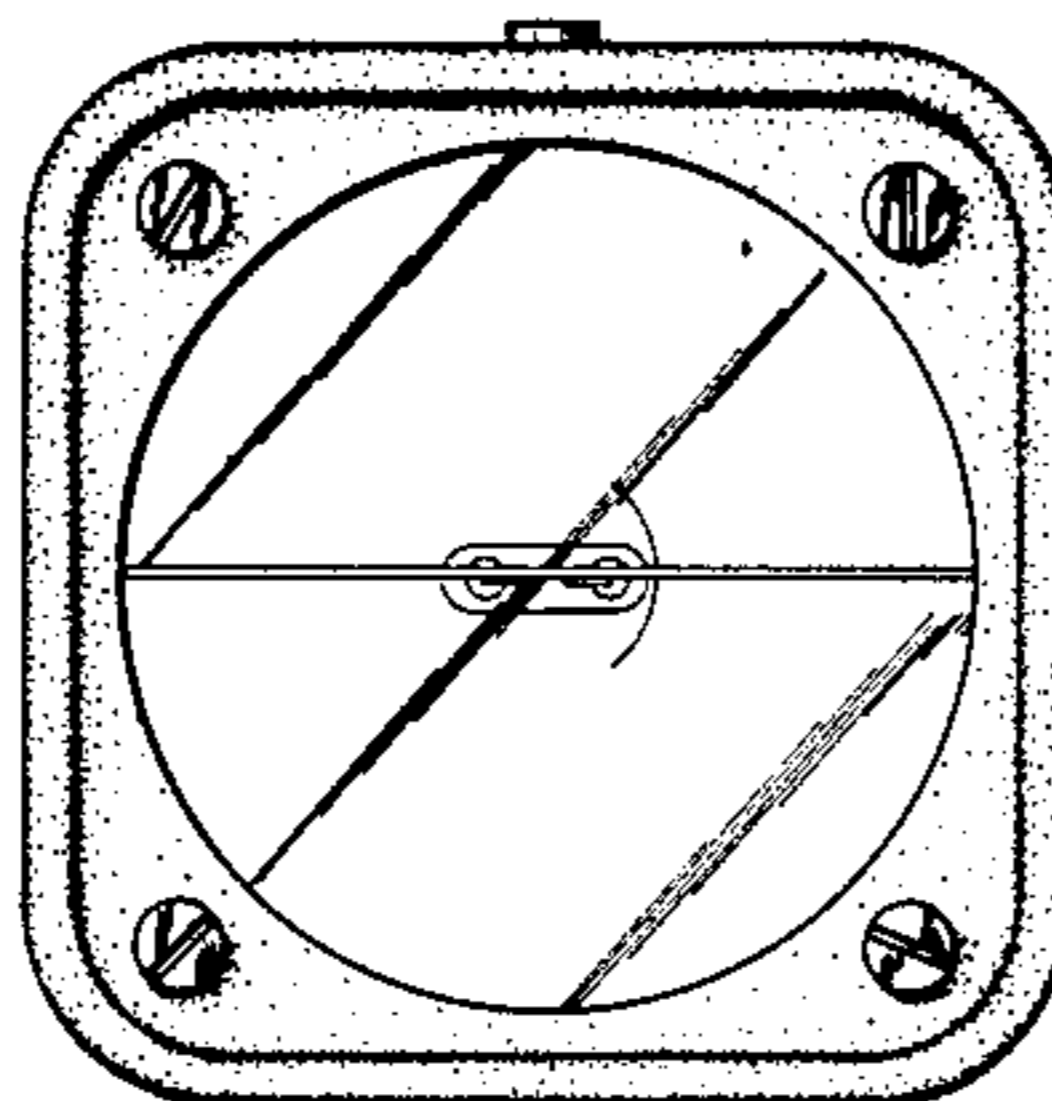
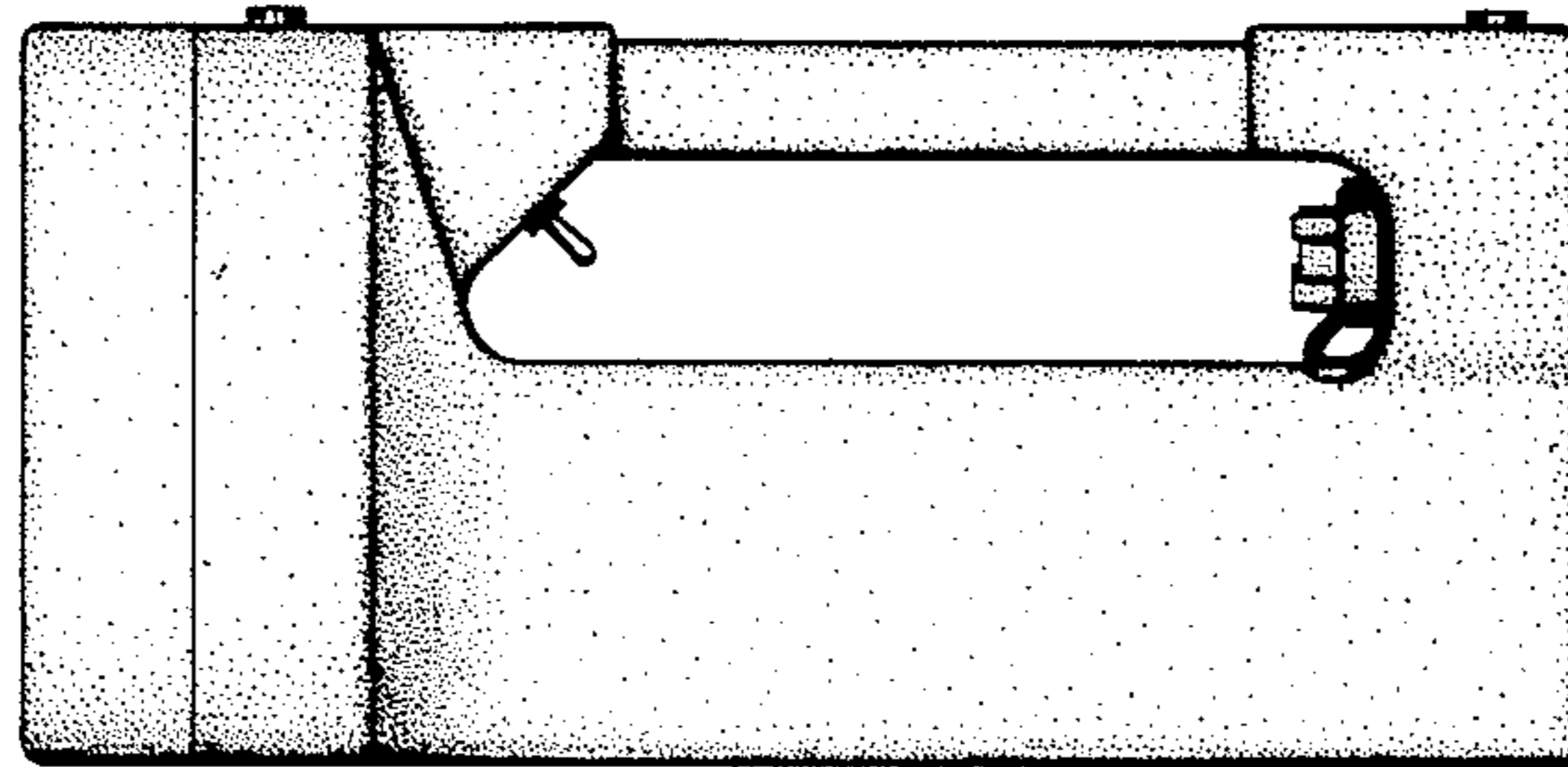

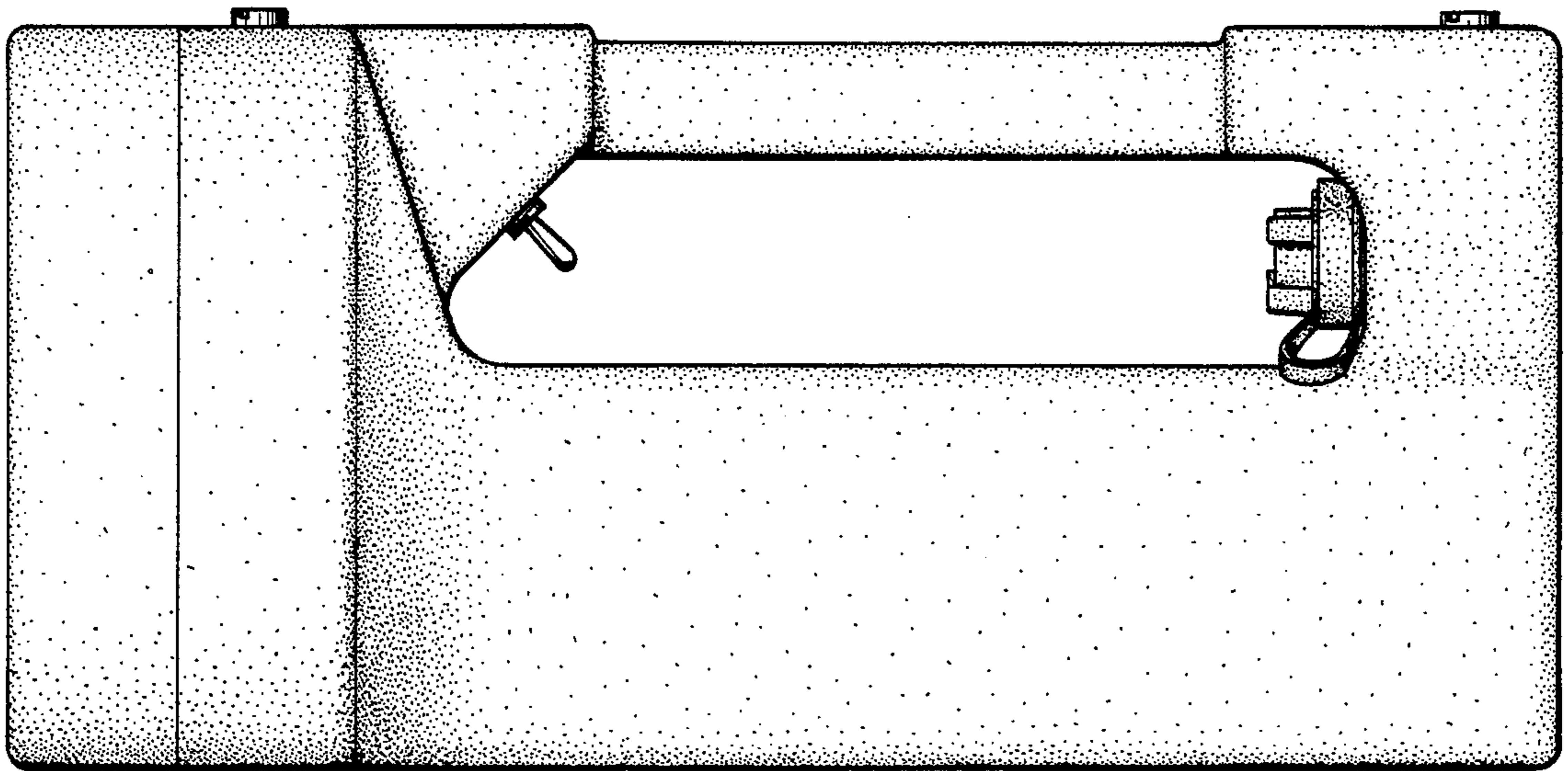

FIG. 1

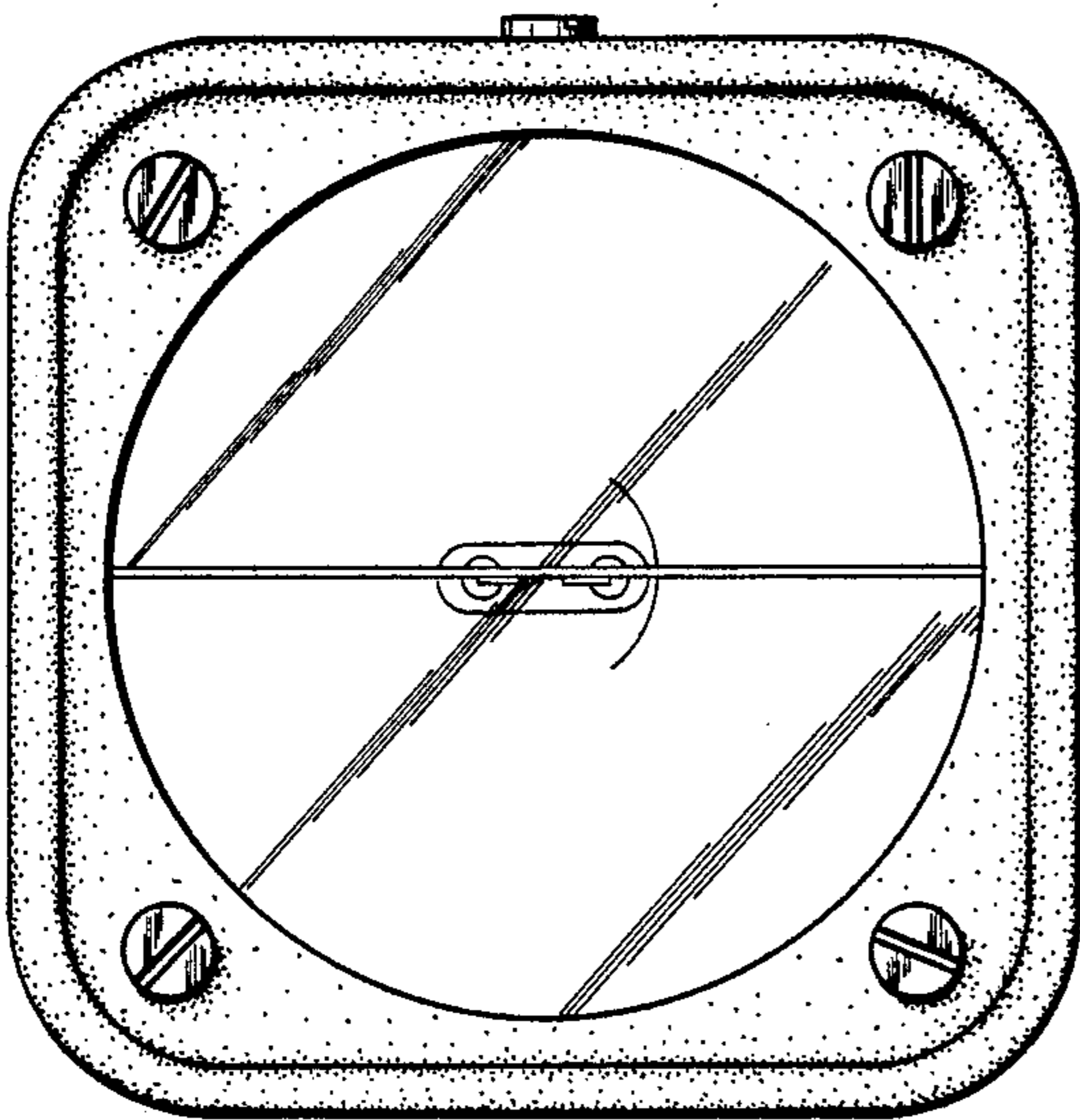

FIG. 2

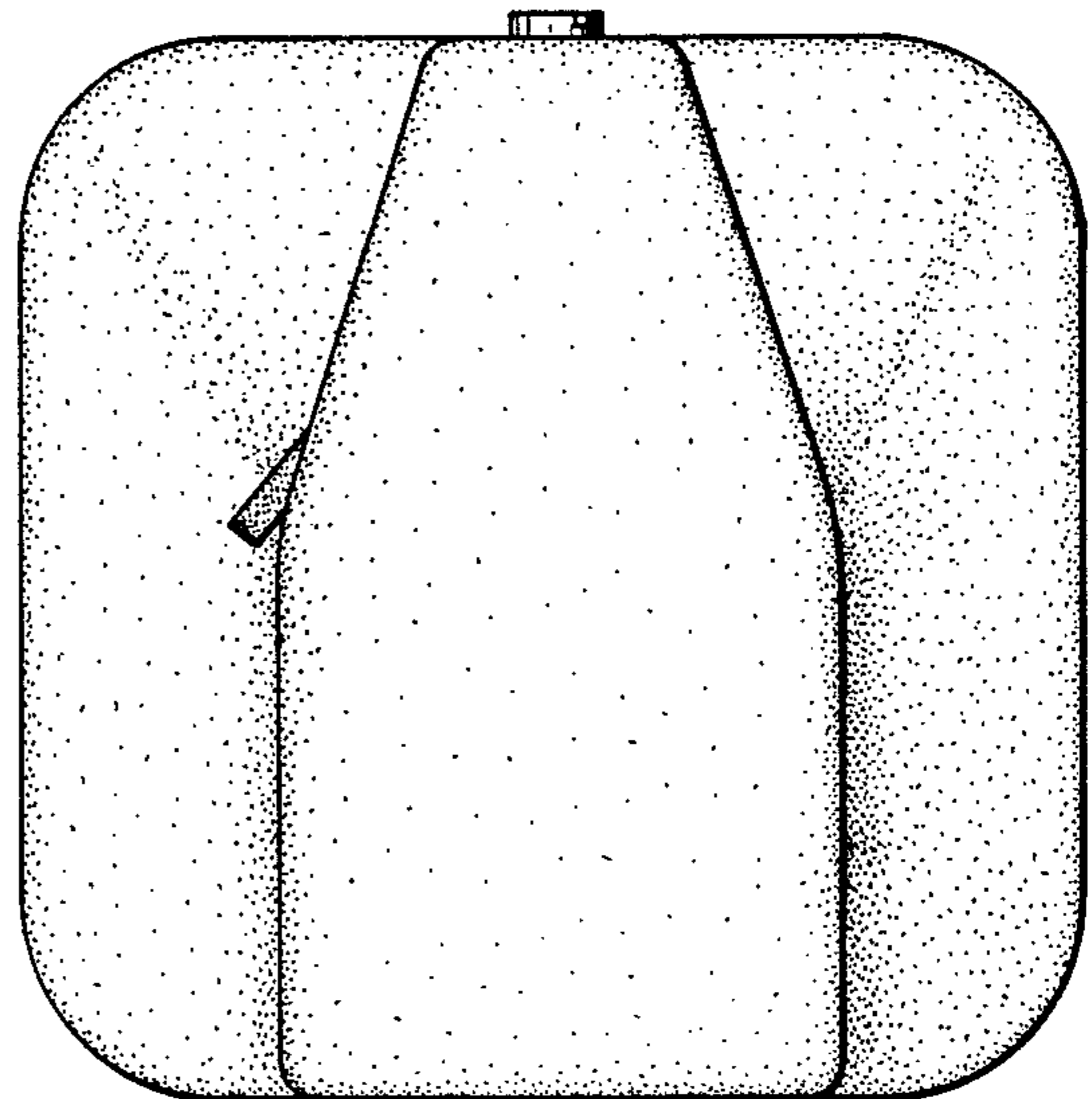

FIG. 3

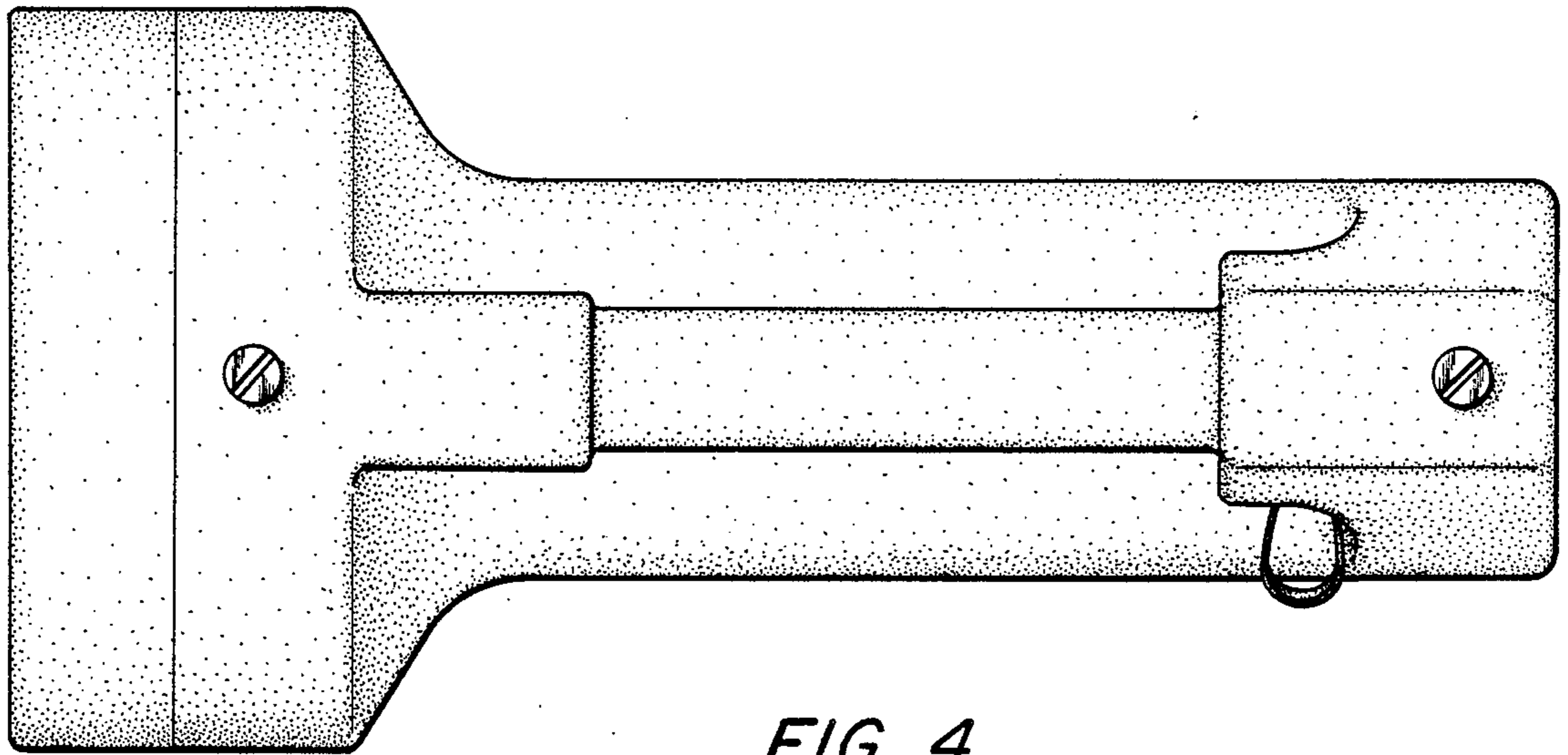

FIG. 4

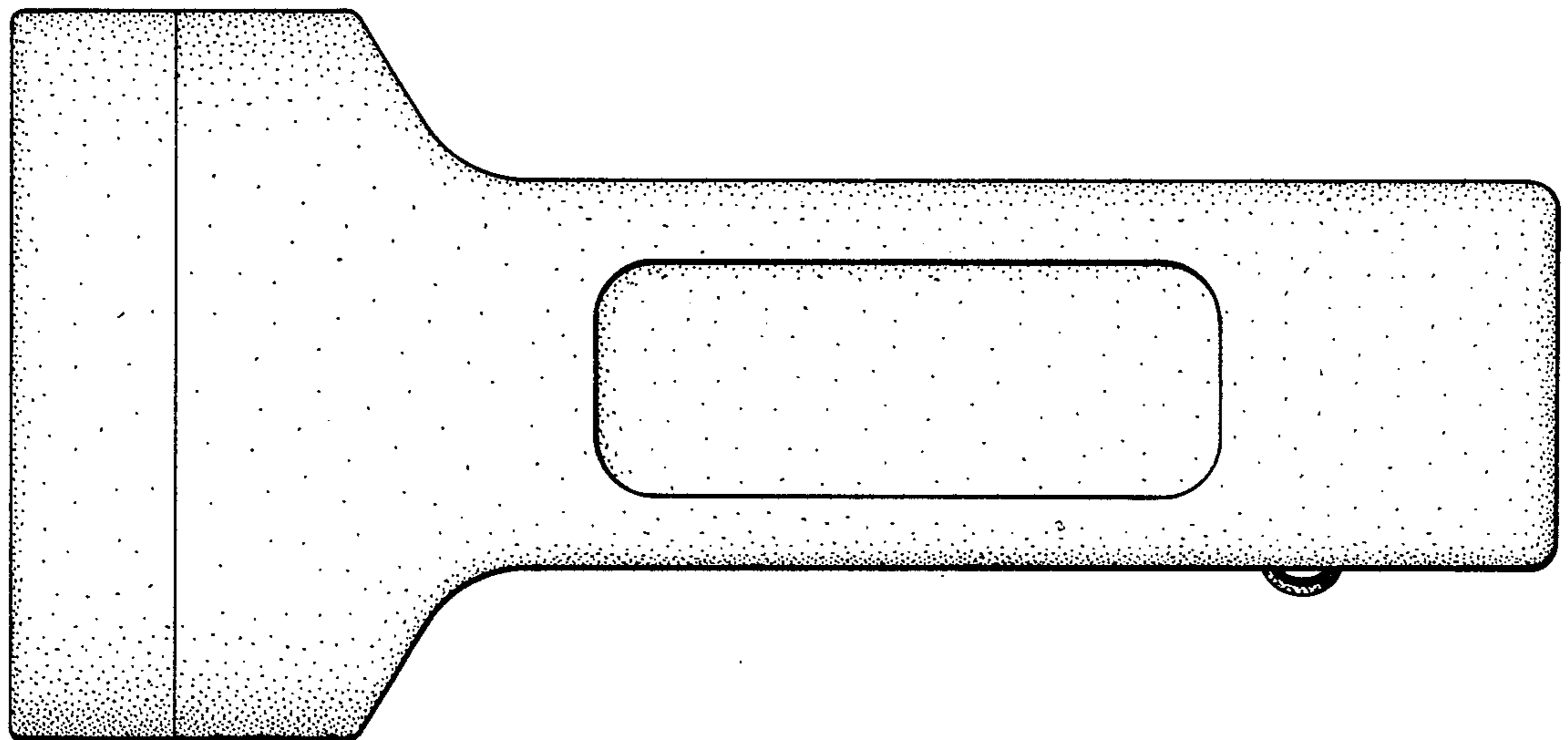

FIG. 5