

[54] TOY VEHICLE

[56]

References Cited

U.S. PATENT DOCUMENTS

[75] Inventors: Takehiko Takahashi; Yoshiyasu Ishii; Susumu Matsumoto; Taira Hanashima, all of Tokyo, Japan

- D. 246,481 11/1977 Nakao D21/137
- D. 252,829 9/1979 Nakao et al. D21/74
- D. 268,405 3/1983 Hanes et al. D21/71
- D. 281,792 12/1985 Nakao et al. D21/78
- 4,261,588 4/1981 Kassai 280/87.021

[73] Assignee: Combi Co., Ltd., Tokyo, Japan

Primary Examiner—Charles A. Rademaker
Assistant Examiner—Alicia A. Farrell
Attorney, Agent, or Firm—Sughrue, Mion, Zinn, Macpeak & Seas

[**] Term: 14 Years

[57] CLAIM

[21] Appl. No.: 132,538

The ornamental design for a toy vehicle, as shown.

[22] Filed: Dec. 14, 1987

DESCRIPTION

[30] Foreign Application Priority Data

- Jun. 15, 1987 [JP] Japan 62-24350
- [52] U.S. Cl. D21/78
- [58] Field of Search D21/71, 73, 74, 75, D21/76, 80, 81; 446/29, 433, 440, 441, 450, 452, 460, 465, 466, 467, 468, 470; 280/87.021

FIG. 1 is a front, top and right side perspective view of a toy vehicle showing our new design;
FIG. 2 is a front perspective view thereof;
FIG. 3 is a rear perspective view thereof;
FIG. 4 is a top plan view thereof;
FIG. 5 is a bottom plan view thereof;
FIG. 6 is a left side elevational view thereof; and
FIG. 7 is a right side elevational view thereof.

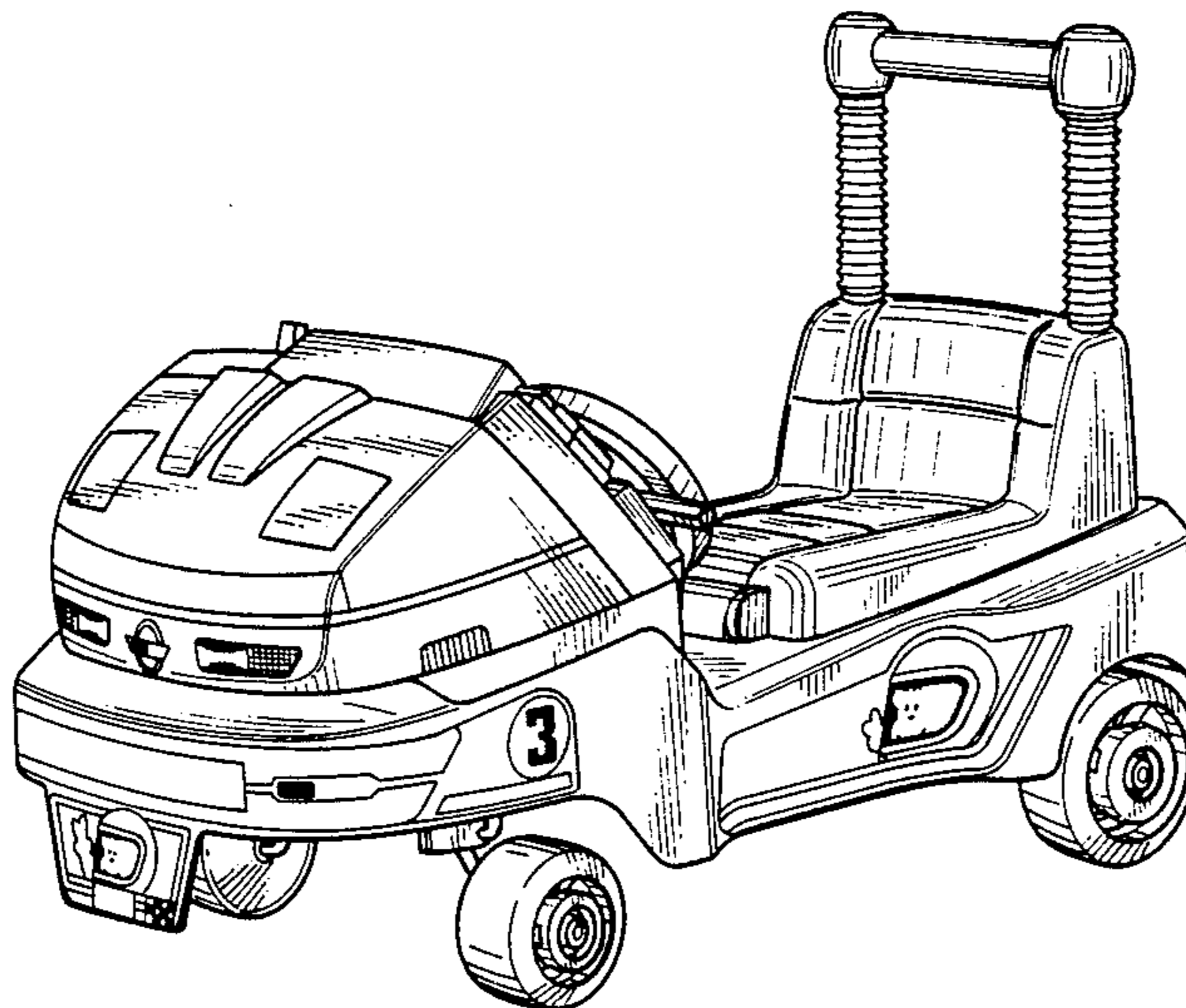

Fig. 1

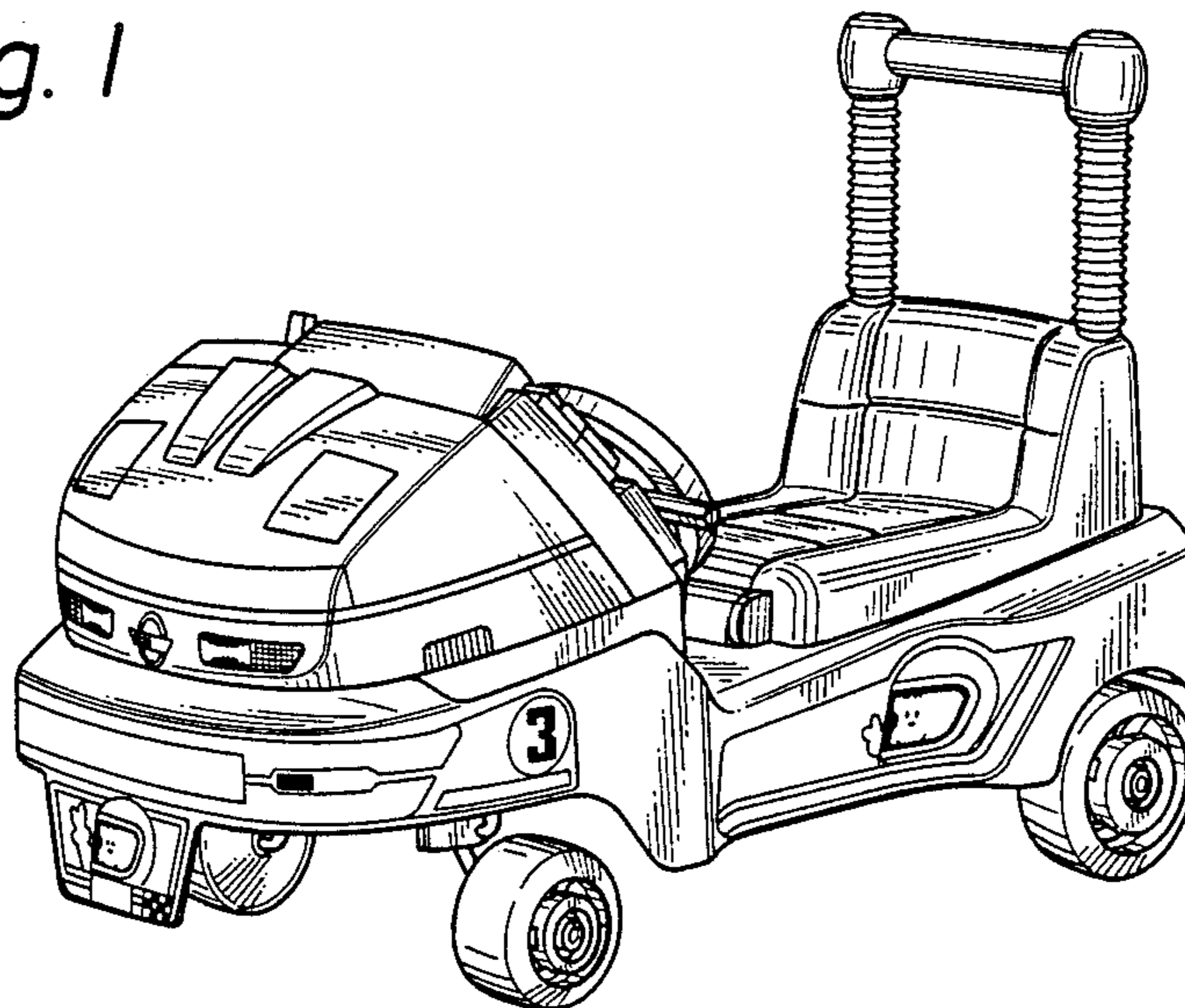

Fig. 2

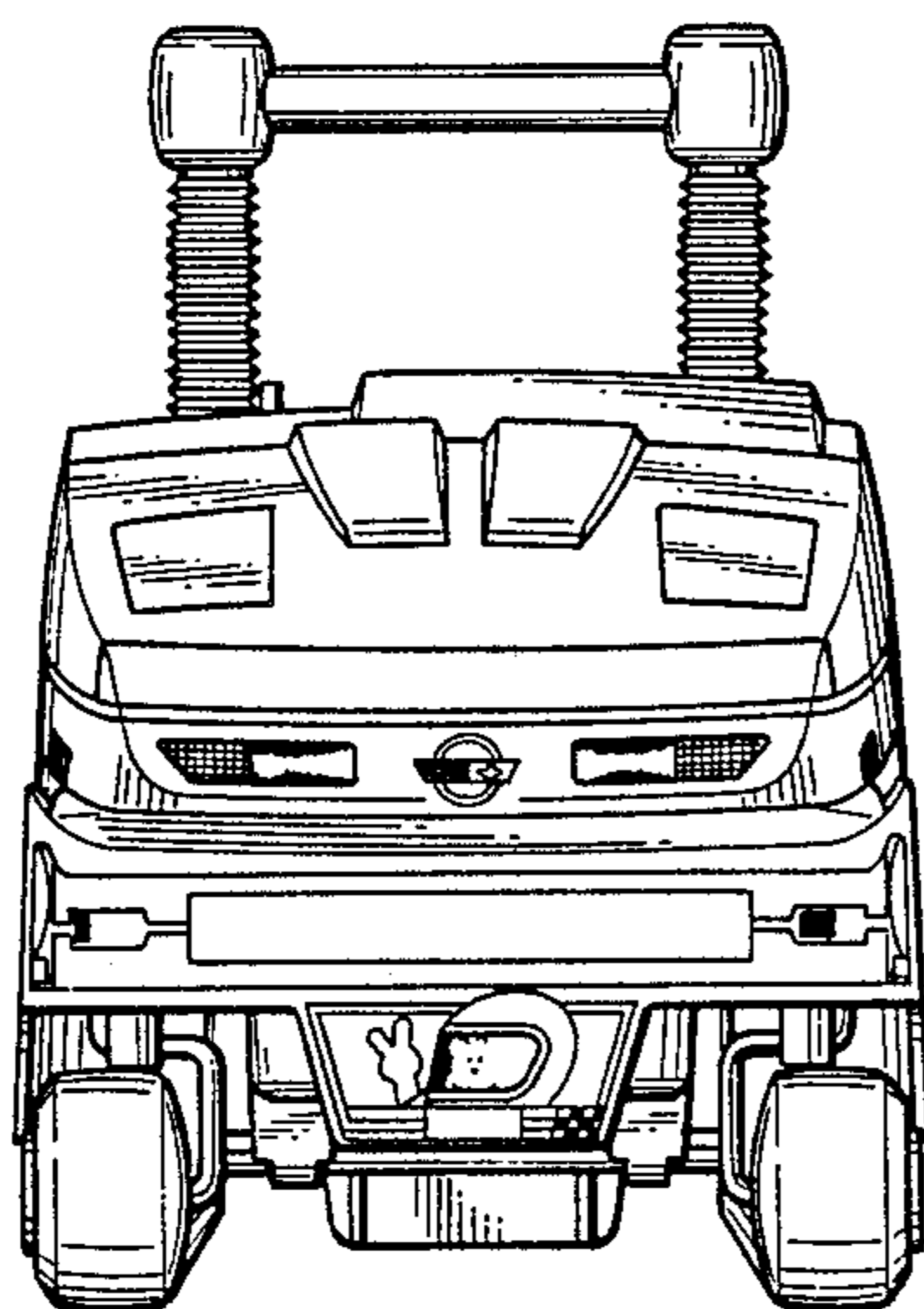

Fig. 3

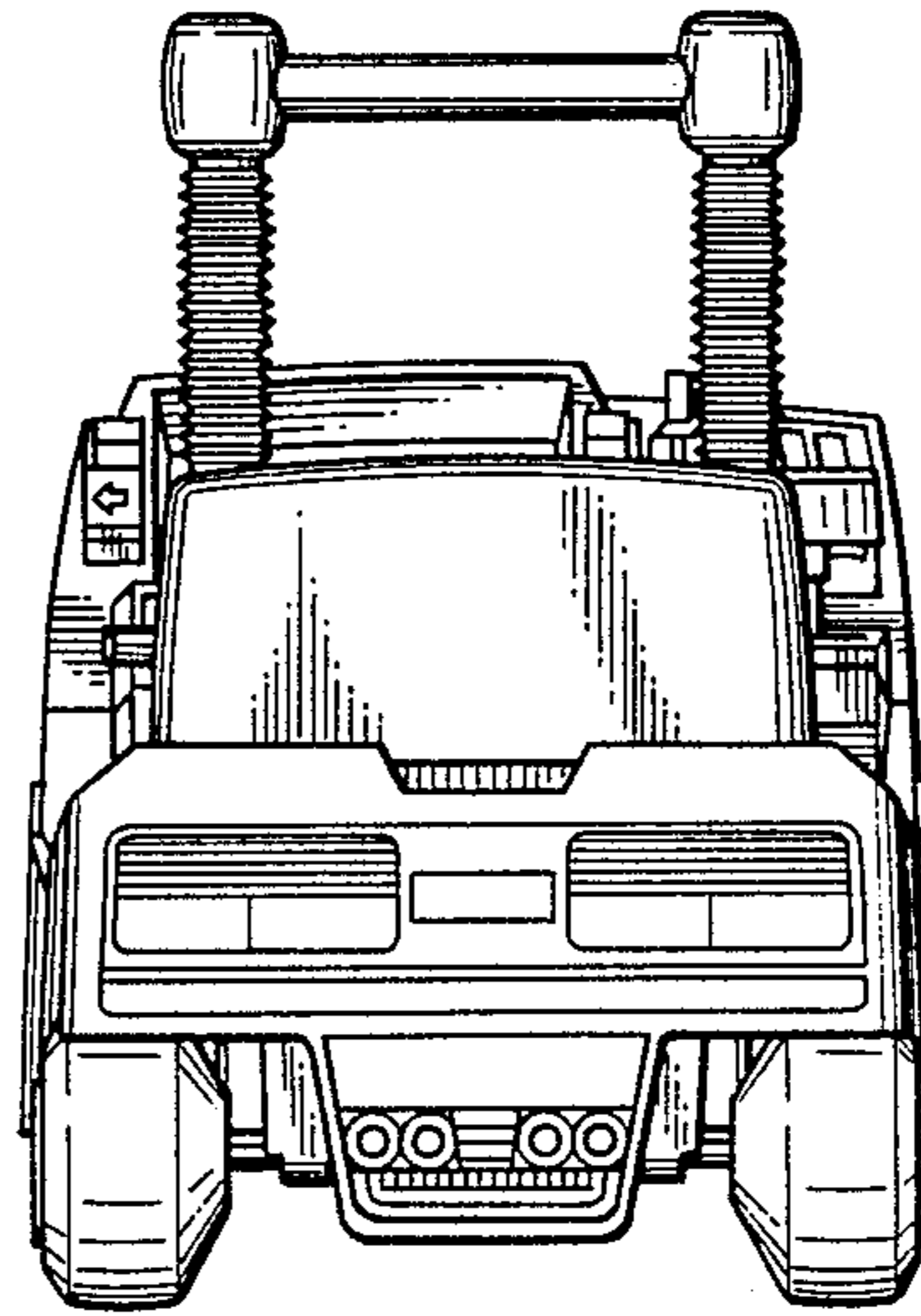

Fig. 4

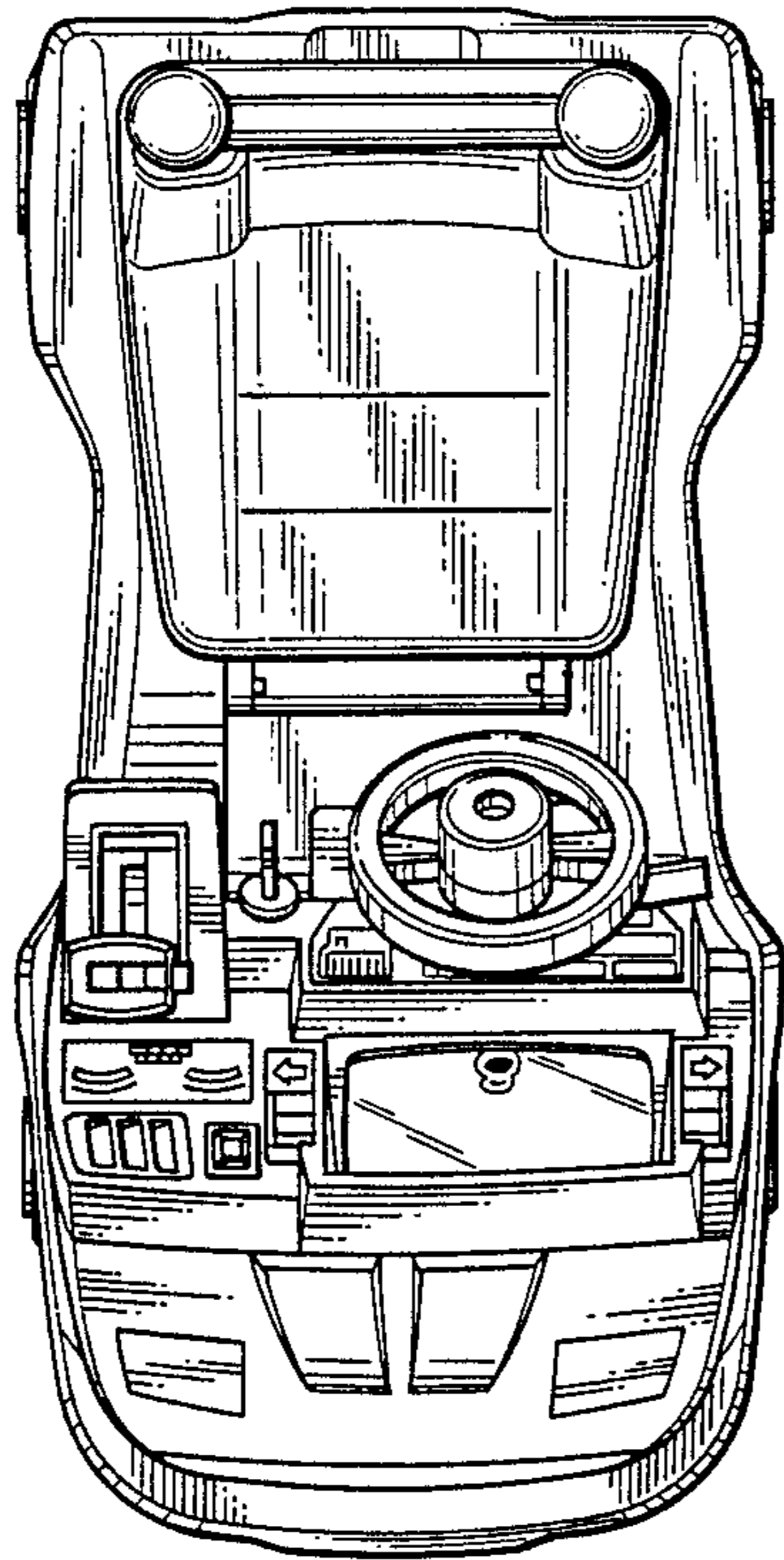

Fig. 5

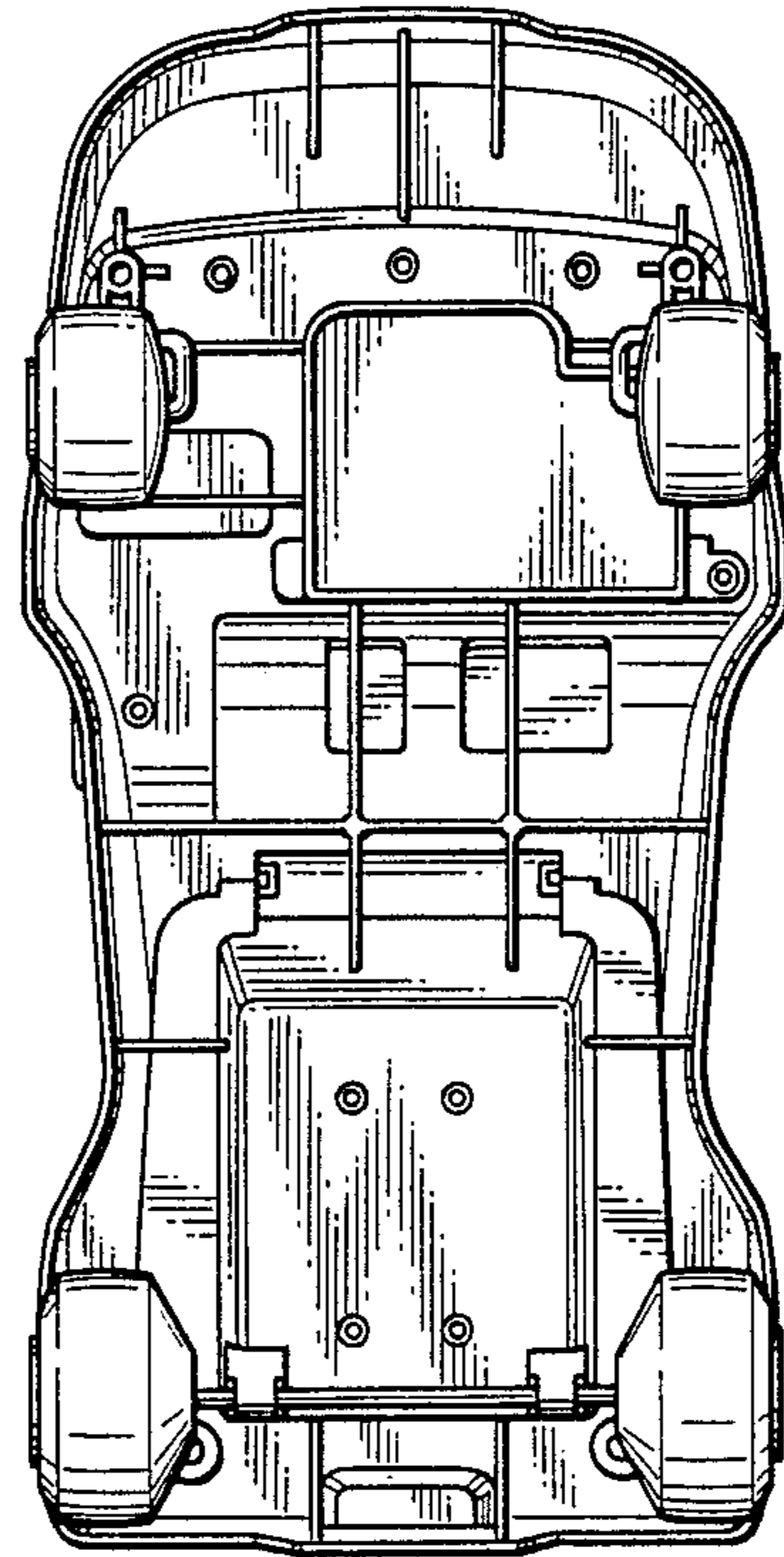

Fig. 6

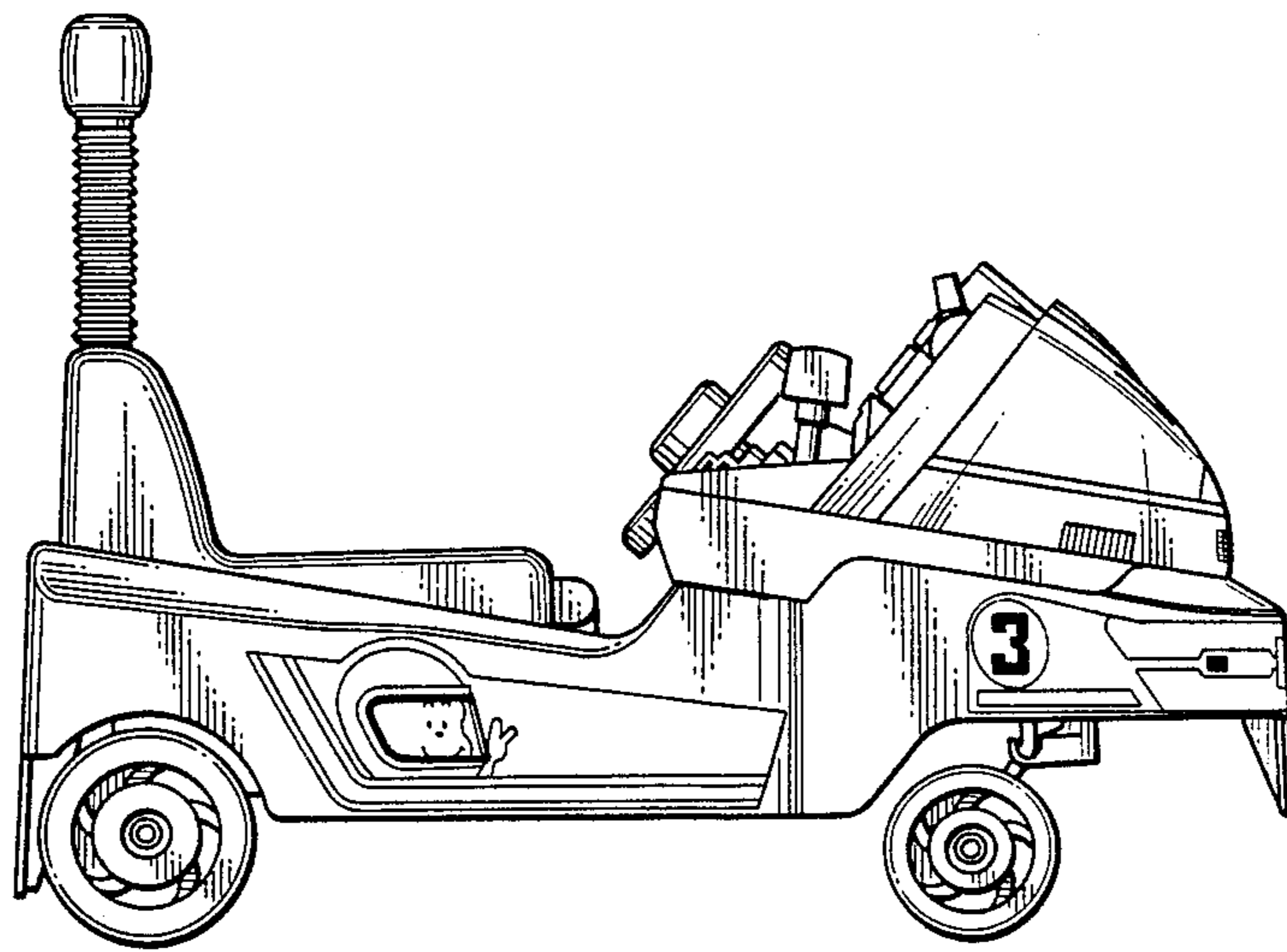

Fig. 7

