

[54] **TOY VEHICLE**

[75] **Inventor:** Lawrence R. Harrod, Fort Wayne, Ind.
[73] **Assignee:** Kransco, San Francisco, Calif.
[**] **Term:** 14 Years
[21] **Appl. No.:** 224,476
[22] **Filed:** Jul. 26, 1988
[52] **U.S. Cl.** D21/78; D21/136
[58] **Field of Search** D21/59, 71, 73, 74, D21/76, 77, 78, 79, 80, 124, 128, 132-137, 140; D12/13, 82, 85, 86, 88, 90, 91, 92, 112; 280/1.12, 1.13, 1.21, 1.22, 1.5, 3, 4, 7.15, 87.01, 87.05, 200, 651, 47.371, 87.021, 655.1, 828; 446/85, 88, 93-95, 432, 440, 450, 451, 465, 466, 468, 470, 487

[56] **References Cited**

U.S. PATENT DOCUMENTS

D. 189,582 1/1961 Gurr D21/78
D. 227,921 7/1973 Tachi D21/136
3,566,536 3/1971 Baynes et al. 446/465

FOREIGN PATENT DOCUMENTS

536040 9/1958 Italy 446/470

OTHER PUBLICATIONS

Sears Wish Book, 1985, p. 572, #5, "Jaguar", bottom photo.

Primary Examiner—Charles A. Rademaker
Assistant Examiner—Alicia A. Farrell
Attorney, Agent, or Firm—Kolisich, Hartwell & Dickinson

[57] **CLAIM**

The ornamental design for a toy vehicle, as shown and described.

DESCRIPTION

FIG. 1 is a left side elevational view of a toy vehicle showing my new design; the side opposite being a mirror image;
FIG. 2 is a top plan view thereof;
FIG. 3 is a front elevational view thereof;
FIG. 4 is a rear elevational view thereof; and
FIG. 5 is a bottom plan view thereof.

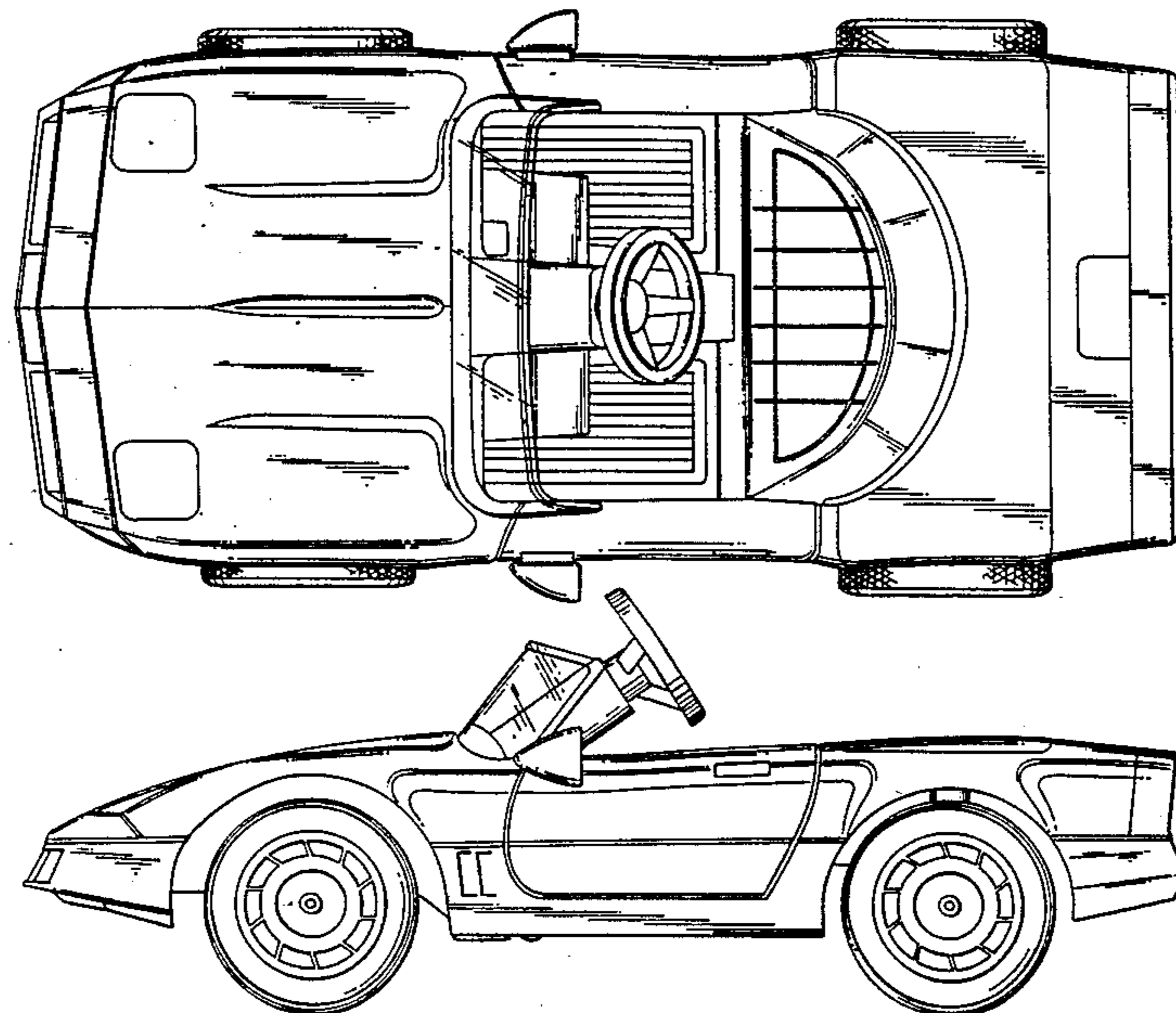

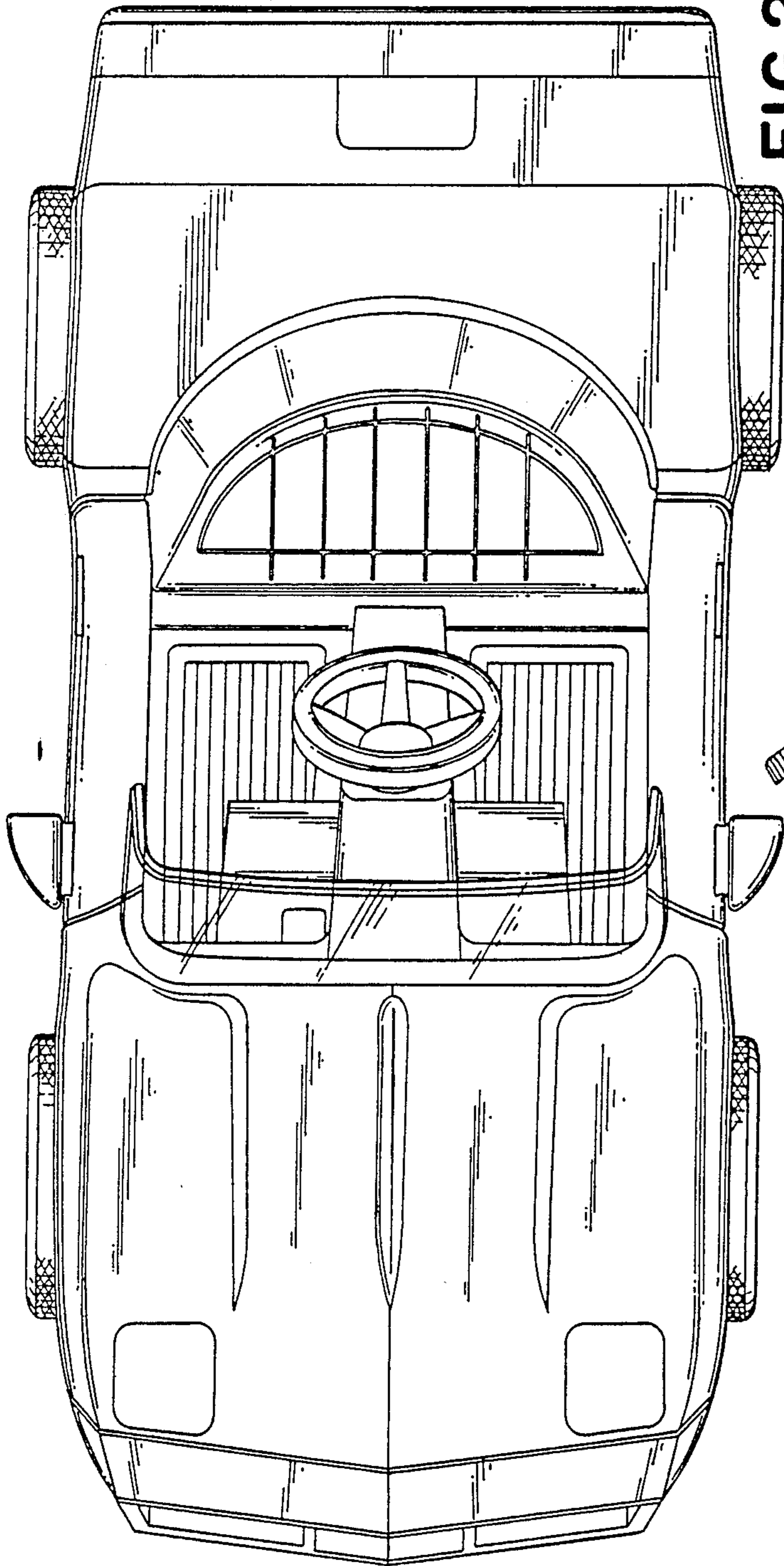

FIG.2

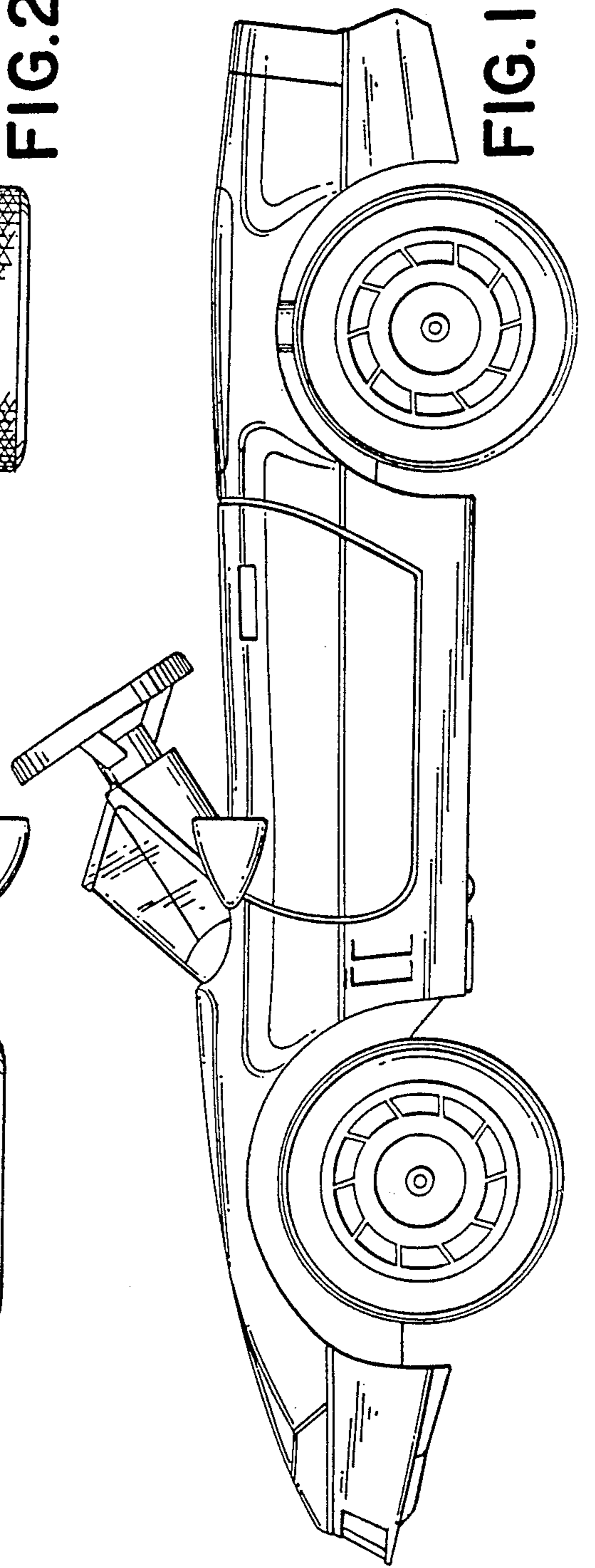

FIG.1

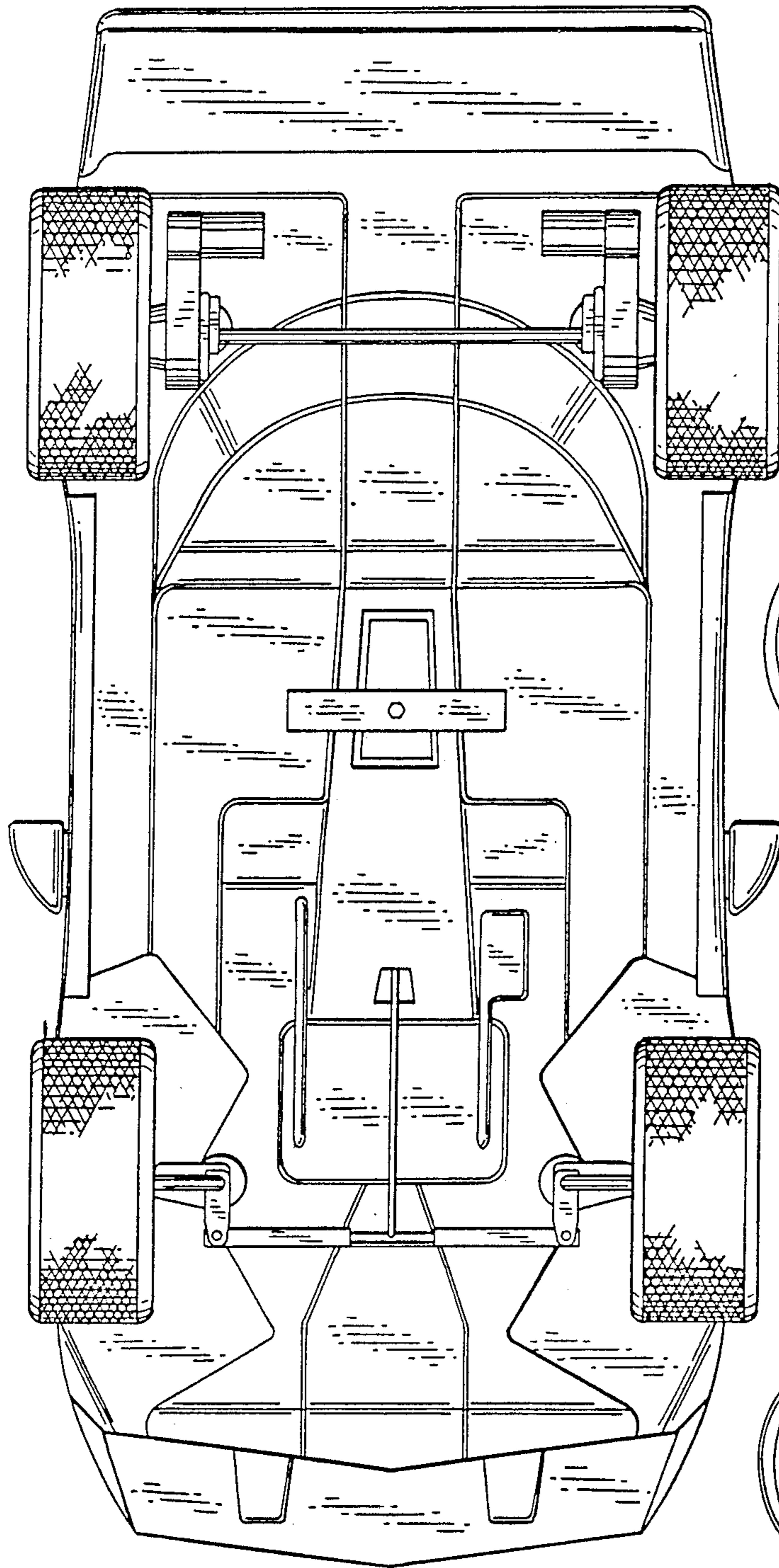

FIG. 5

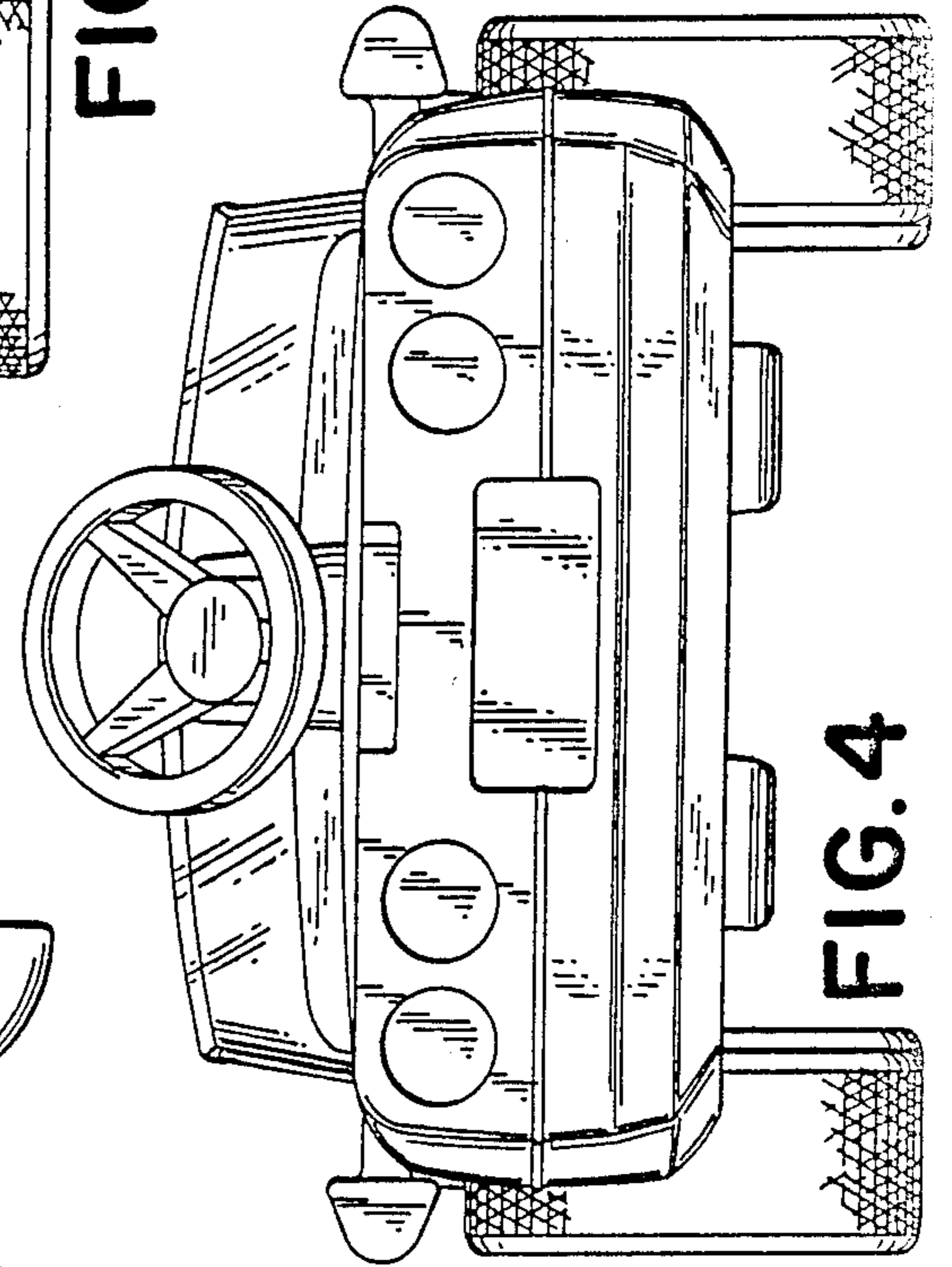

FIG. 4

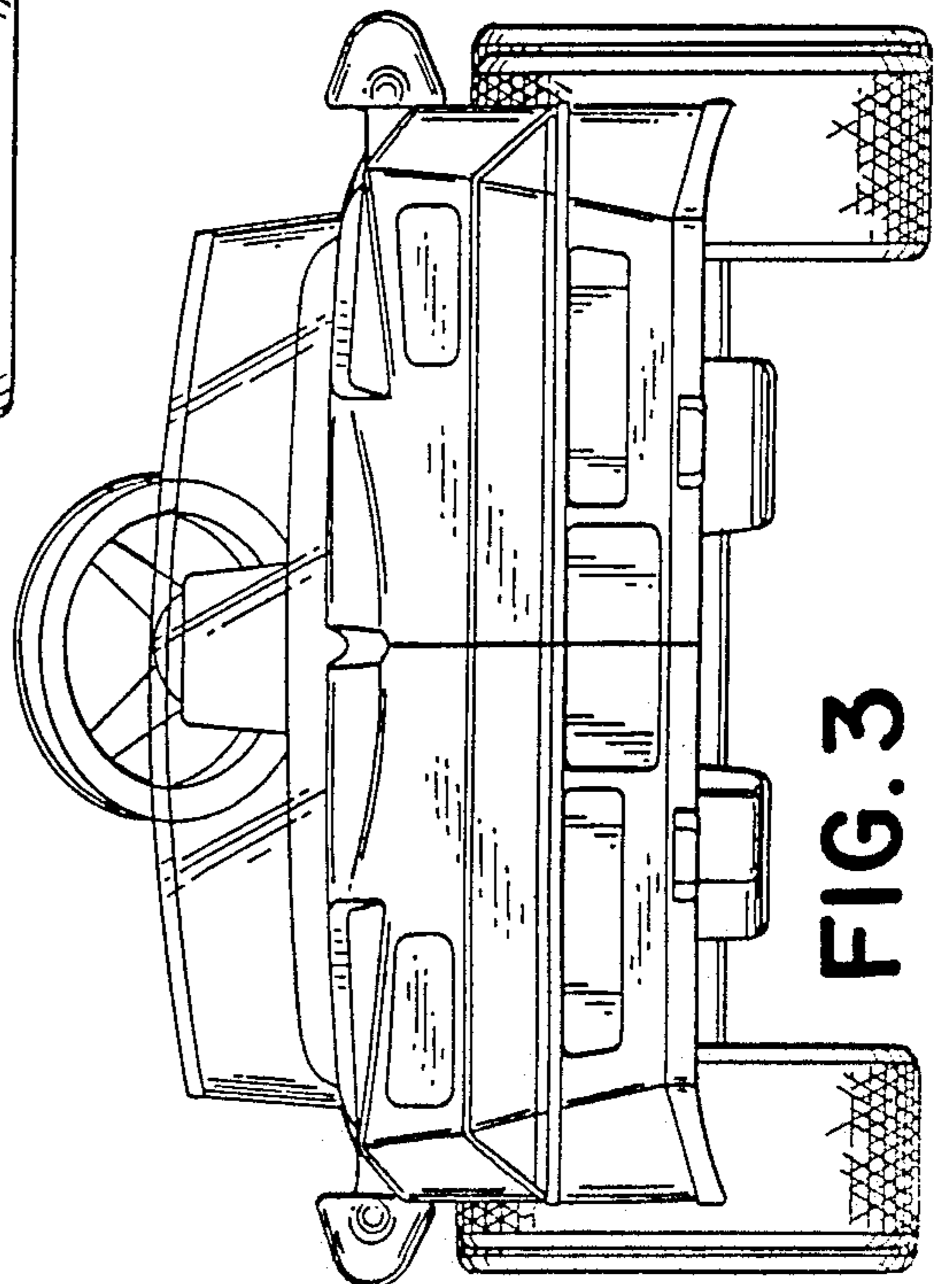

FIG. 3