

[54] AIRCRAFT

[75] Inventor: Cecil W. Haga, Arlington, Tex.

[73] Assignee: The Ishida Foundation, Nagoya, Japan

[\*\*] Term: 14 Years

[21] Appl. No.: 252,714

[22] Filed: Sep. 30, 1988

[52] U.S. Cl. .... D12/328; D12/331; D12/344

[58] Field of Search ..... D12/319, 328, 331, 337, D12/344, 326; 244/45 A, 45 R, 55, 13, 91, 199

[56] References Cited

U.S. PATENT DOCUMENTS

2,910,254 10/1959 Razak ..... D12/331

OTHER PUBLICATIONS

Flight Int'l, Jul. 31, 1982, p. 259, Bell's Tilt-Rotor JVX Medium-Lift Rotorcraft.

Flight-Int'l, 3/10 Jan. 1987, p. 26, Canadair CL-215T. "The Complete Illustrated Encyclopedia of the World's Aircraft", David Mondey, pp. 191, 212, Hiller X-18 Tilt

Wing VTOL & LTV-Hiller-Ryan XC-142A Tilt Wing VTOL.

"XC-142", pp. 50-54 (Japanese language article).

Primary Examiner—Kay H. Chin

Attorney, Agent, or Firm—Sughrue, Mion, Zinn, Macpeak & Seas

[57] CLAIM

The ornamental design for an aircraft, as shown and described.

DESCRIPTION

FIG. 1 is a top, front and left side perspective view of an aircraft showing my new design;

FIG. 2 is a front elevational view thereof;

FIG. 3 is a rear elevational view thereof;

FIG. 4 is a top plan view thereof;

FIG. 5 is a bottom plan view thereof;

FIG. 6 is a left side elevational view thereof;

FIG. 7 is a right side elevational view thereof;

FIG. 8 is a top and front perspective view thereof showing the tilt wing in a vertical position; and

FIG. 9 is a top, front and left side perspective view of a second embodiment of the aircraft.

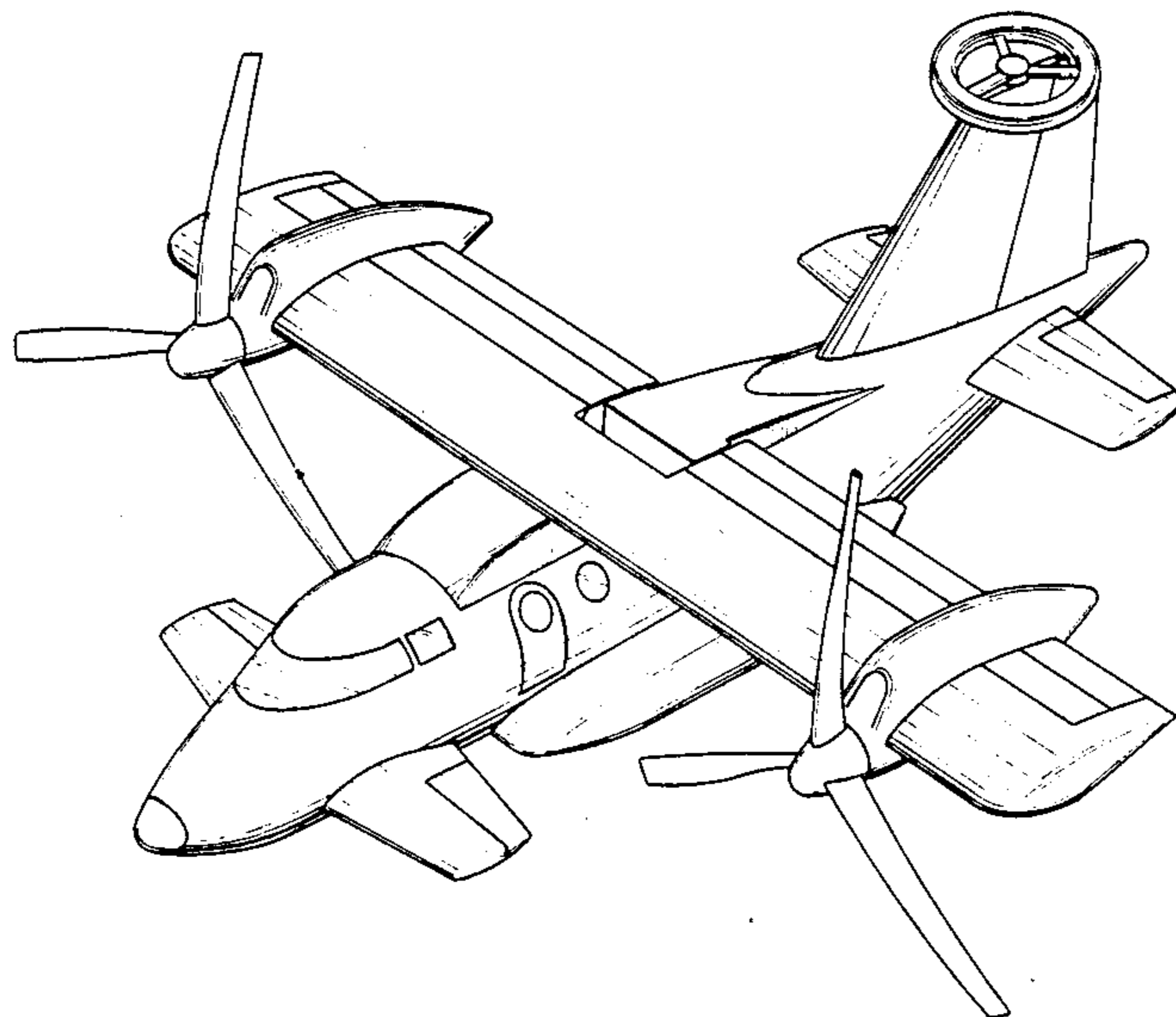

FIG. 1

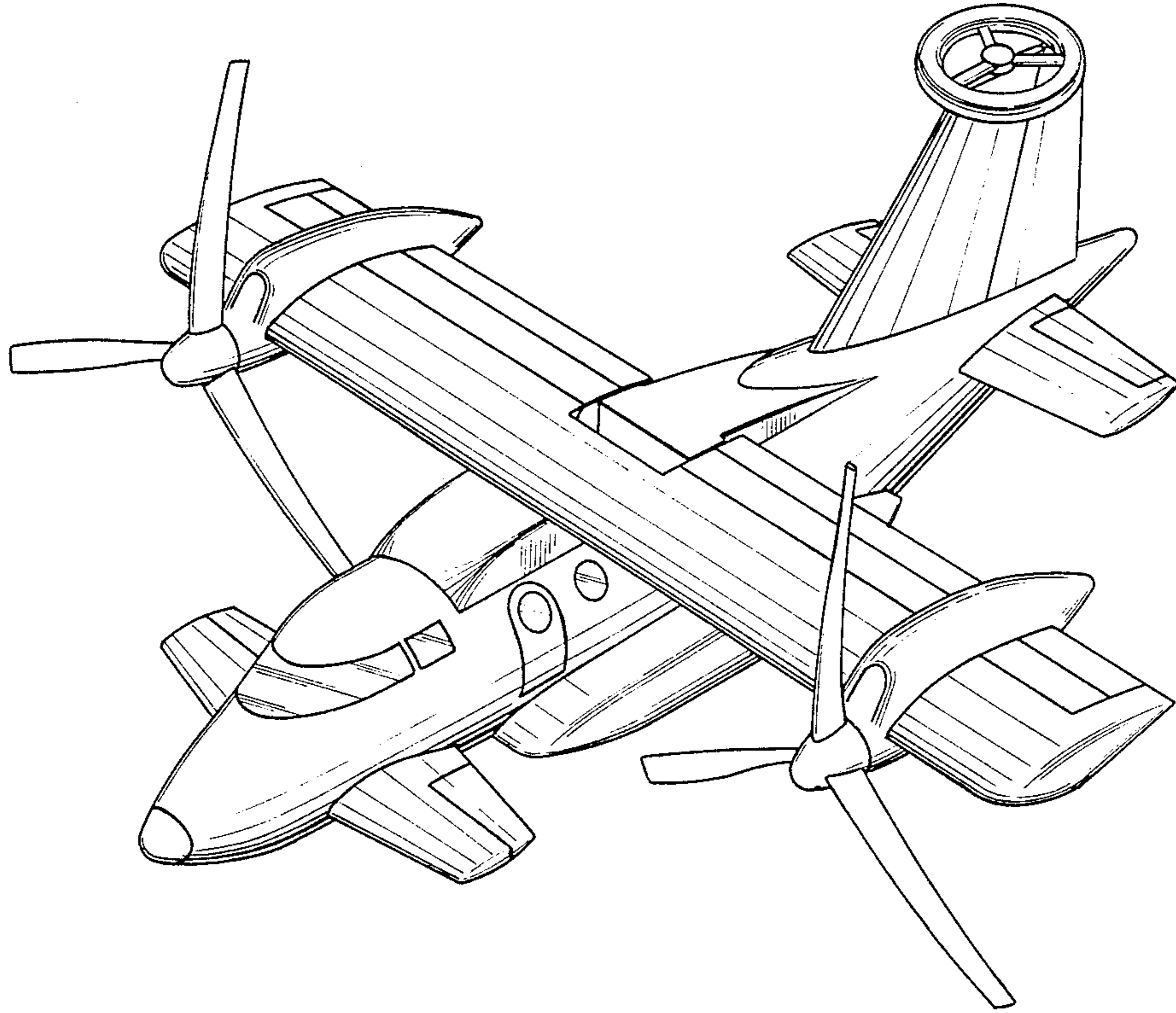

FIG. 2

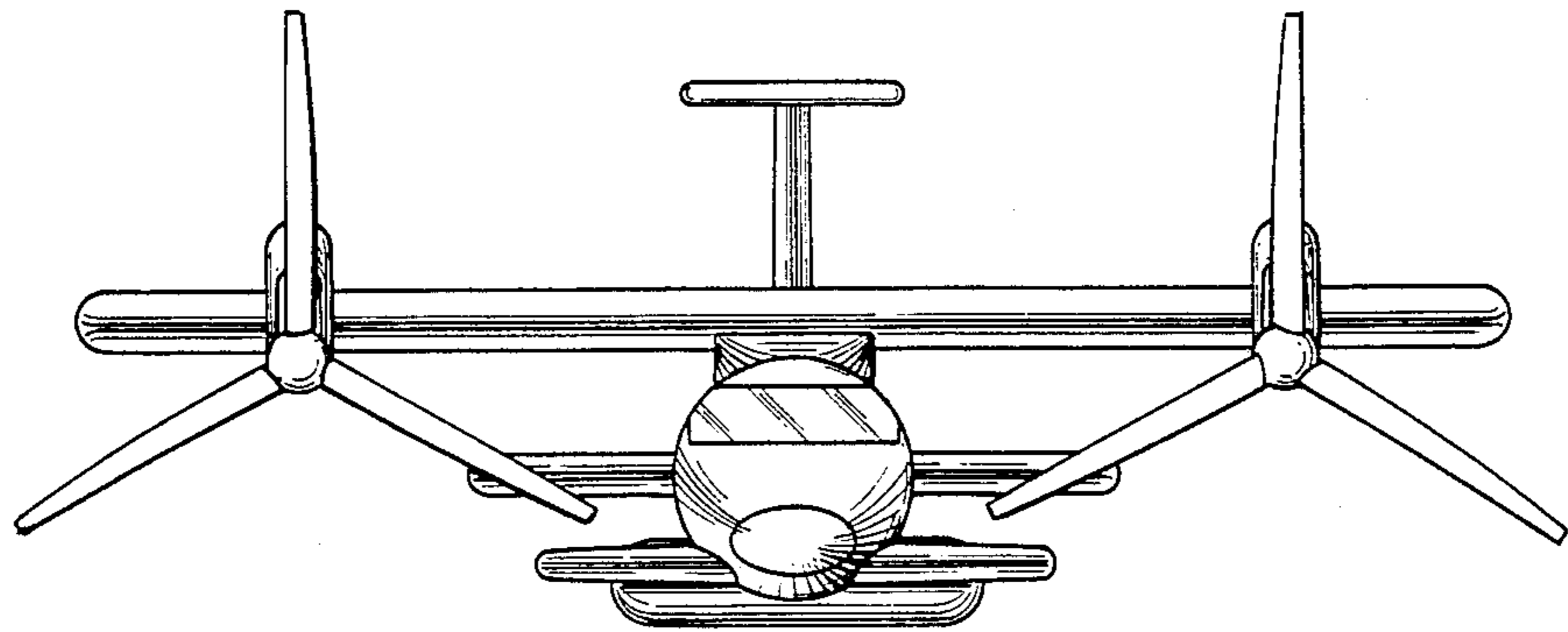

FIG. 3

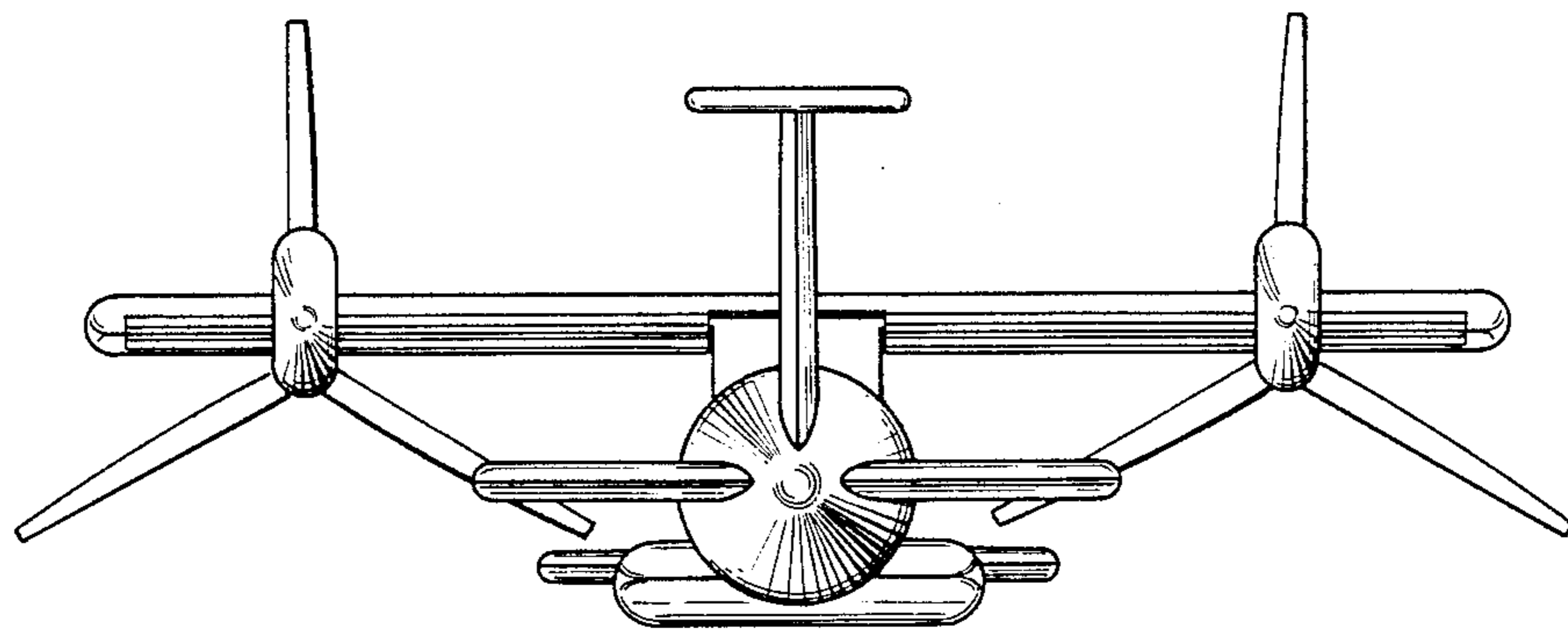

FIG. 4

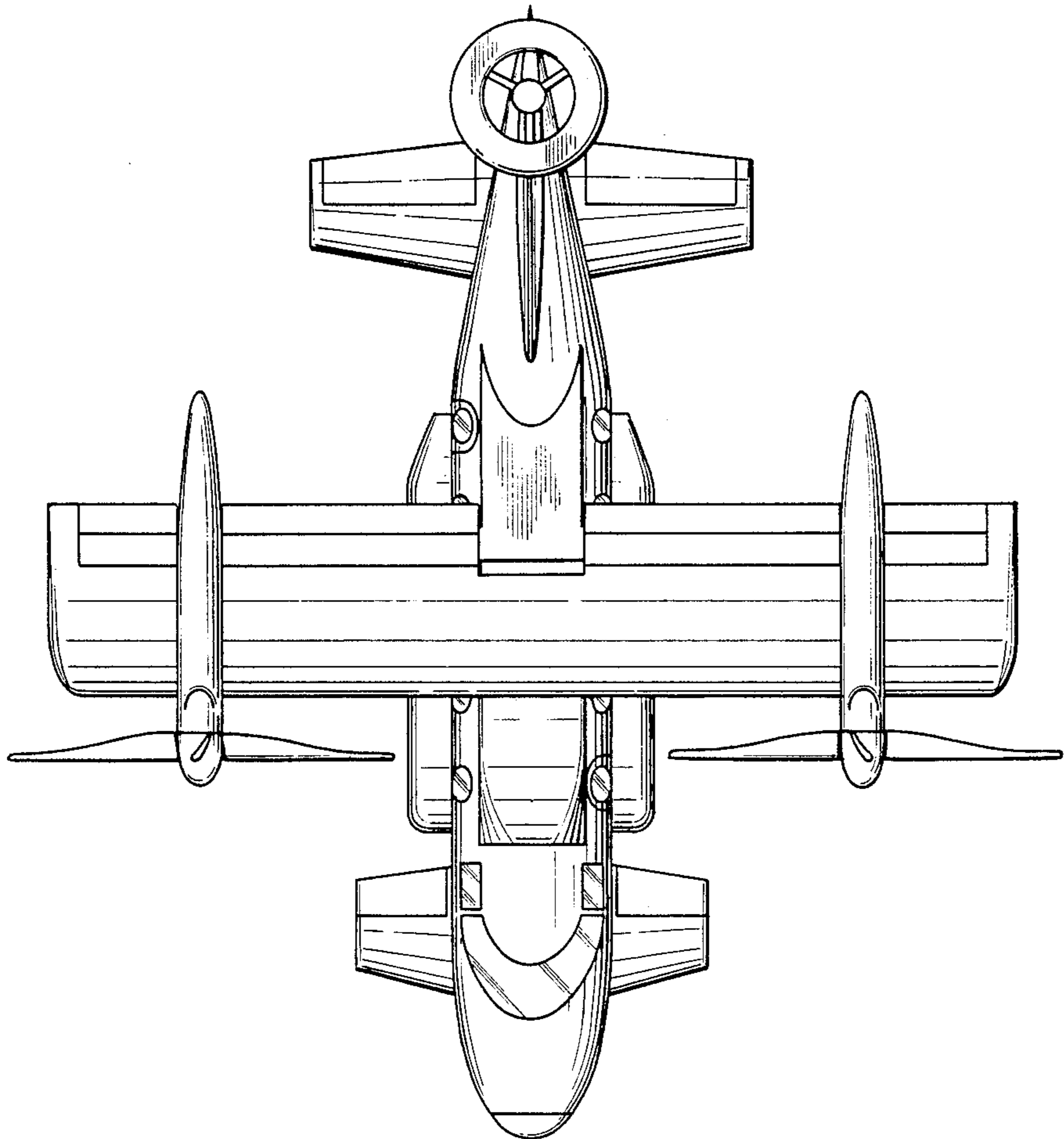

FIG. 5

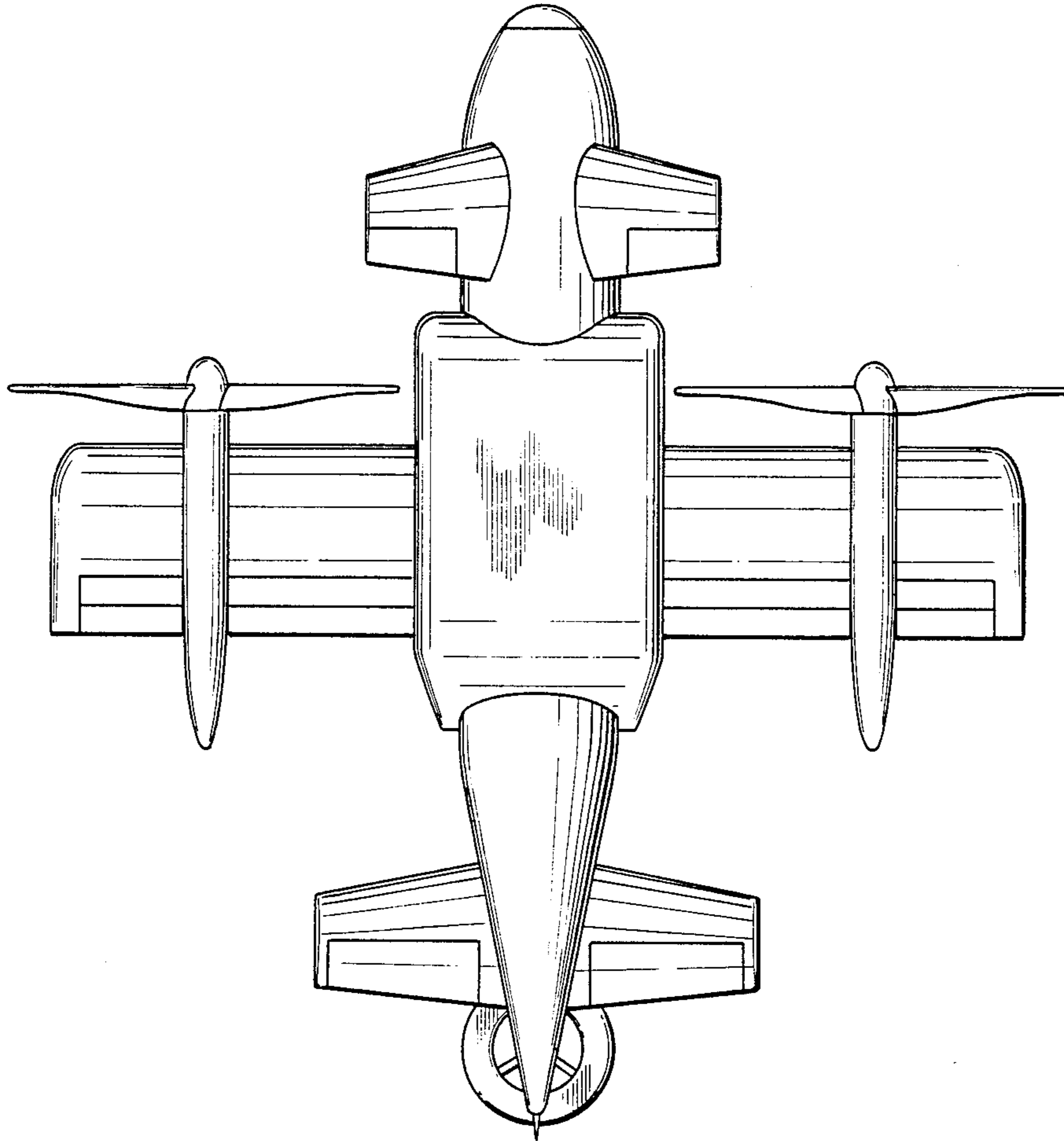



FIG. 6

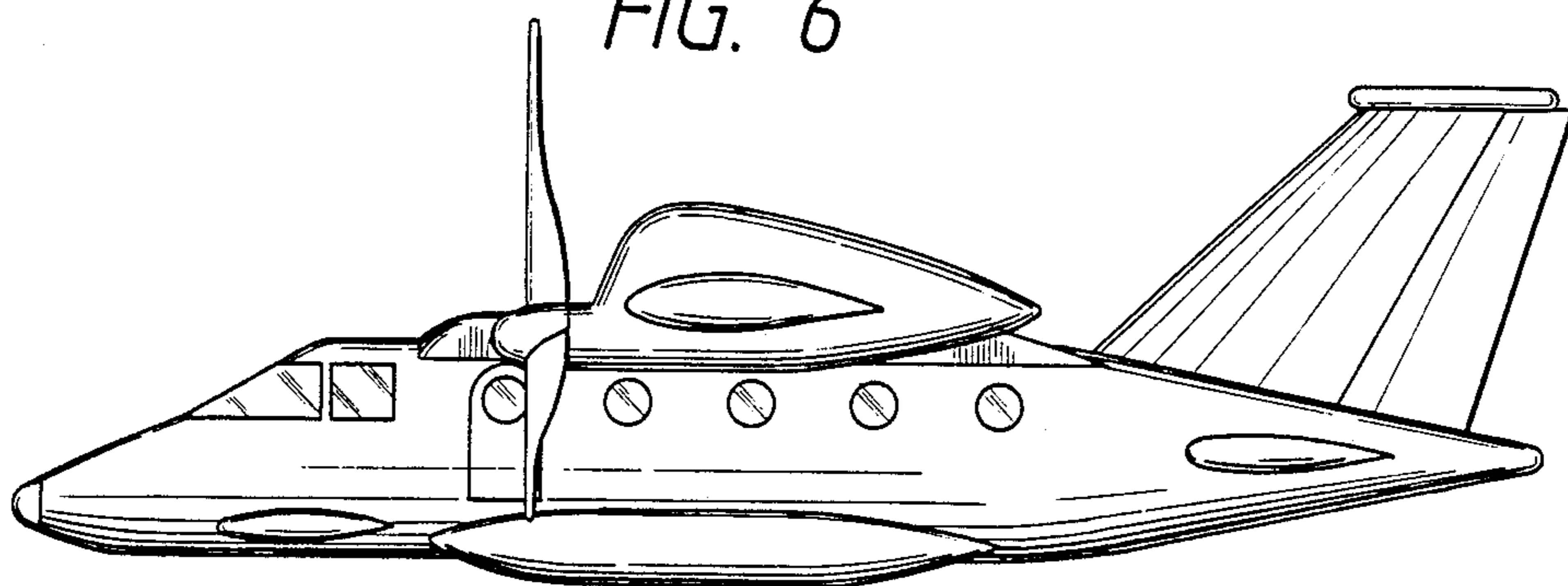

FIG. 7

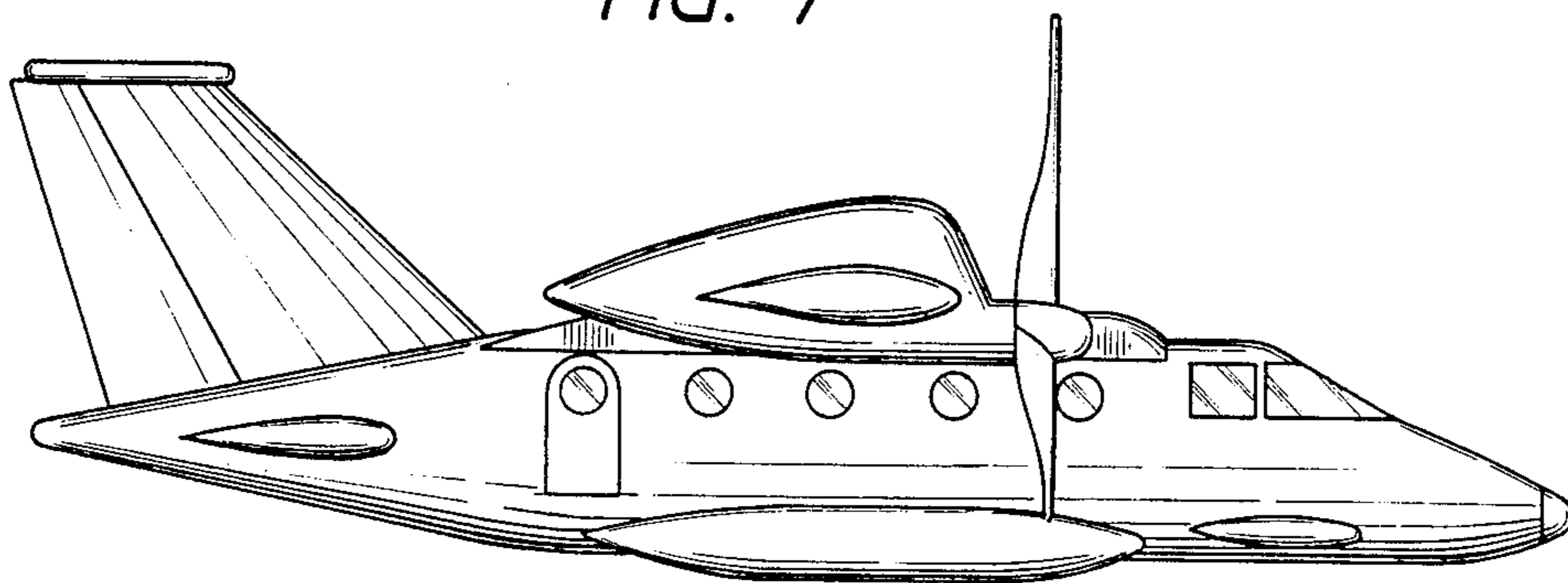

FIG. 8

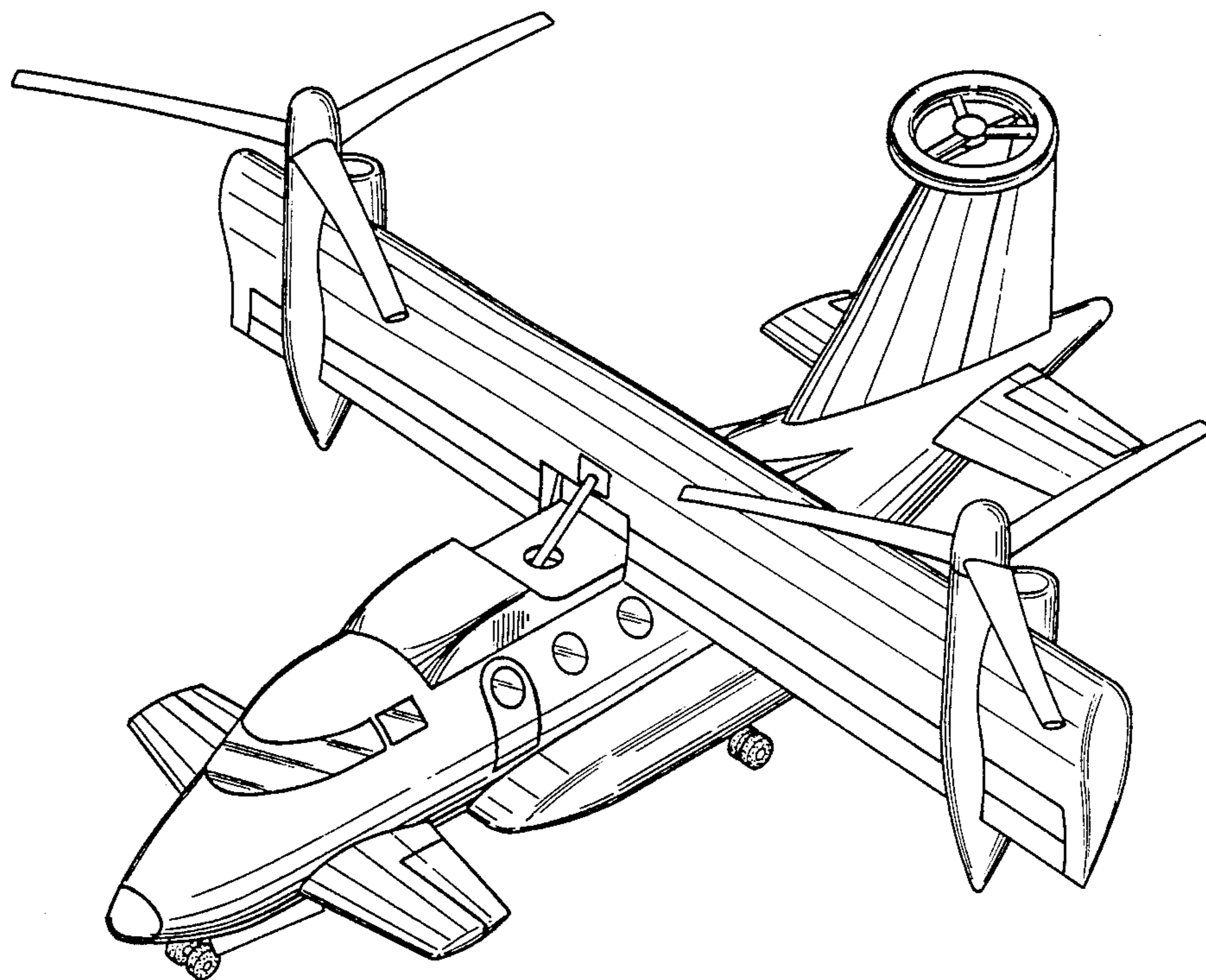

FIG. 9

