

[54] EXTERIOR SHELL OF A MOTORCYCLE FRONT FAIRING UNIT

[75] Inventors: Toshiyuki Yamada, Saitama; Eiji Hamano, Tokyo, both of Japan

[73] Assignee: Honda Giken Kogyo Kabushiki Kaisha, Tokyo, Japan

[**] Term: 14 Years

[21] Appl. No.: 123,170

[22] Filed: Nov. 20, 1987

[52] U.S. Cl. D12/182

[58] Field of Search D12/182; 296/78.1

[56] References Cited

U.S. PATENT DOCUMENTS

- 4,135,758 1/1979 Clements 296/78.1
- 4,178,033 12/1979 Muth et al. 296/78.1
- 4,331,358 5/1982 Johnson et al. 296/78.1

OTHER PUBLICATIONS

Cycle World, Jun. 86, p. 41, Honda Motorcycle Fairing (rt. side of page), p. 86, Kawasaki Ninja Motorcycle Fairing.

Cycle World, May 86, p. 54, Honda Motorcycle Fairing, p. 72, Kawasaki Motorcycle Fairing.

Cycle World, Jul. 85, p. 56, Suzuki Motorcycle Fairing.

Cycle World, Apr. 85, p. 40, B.M.W. Motorcycle Fairing.

Primary Examiner—James M. Gandy

Assistant Examiner—Melody Brown

Attorney, Agent, or Firm—Lyon & Lyon

[57] CLAIM

The ornamental design for an exterior shell of a motorcycle front fairing unit, as shown and described.

DESCRIPTION

FIG. 1 is a left front perspective view of an exterior shell of a motorcycle front fairing unit showing our new design, it being understood that the broken line showing of a motorcycle body is for illustrative purposes only and forms no part of the claimed design;

FIG. 2 is a left front perspective view thereof;

FIG. 3 is a right front perspective view thereof;

FIG. 4 is a front elevation view thereof;

FIG. 5 is a left side elevation view thereof;

FIG. 6 is a left front perspective view of an exterior shell of a motorcycle front fairing unit showing a second embodiment of our new design;

FIG. 7 is a right front perspective view of FIG. 6;

FIG. 8 is a front elevation view of FIG. 6;

FIG. 9 is a left side elevation view of FIG. 6;

FIG. 10 is a left front perspective view of an exterior shell of a motorcycle front fairing unit showing a third embodiment of our new design;

FIG. 11 is a right front perspective view of FIG. 10;

FIG. 12 is a front elevation view of FIG. 10;

FIG. 13 is a left side elevation view of FIG. 10;

FIG. 14 is a left front perspective view of an exterior shell of a motorcycle front fairing unit showing a fourth embodiment of our new design;

FIG. 15 is a right front perspective view of FIG. 14;

FIG. 16 is a front elevation view of FIG. 14; and

FIG. 17 is a left side elevation view of FIG. 14.

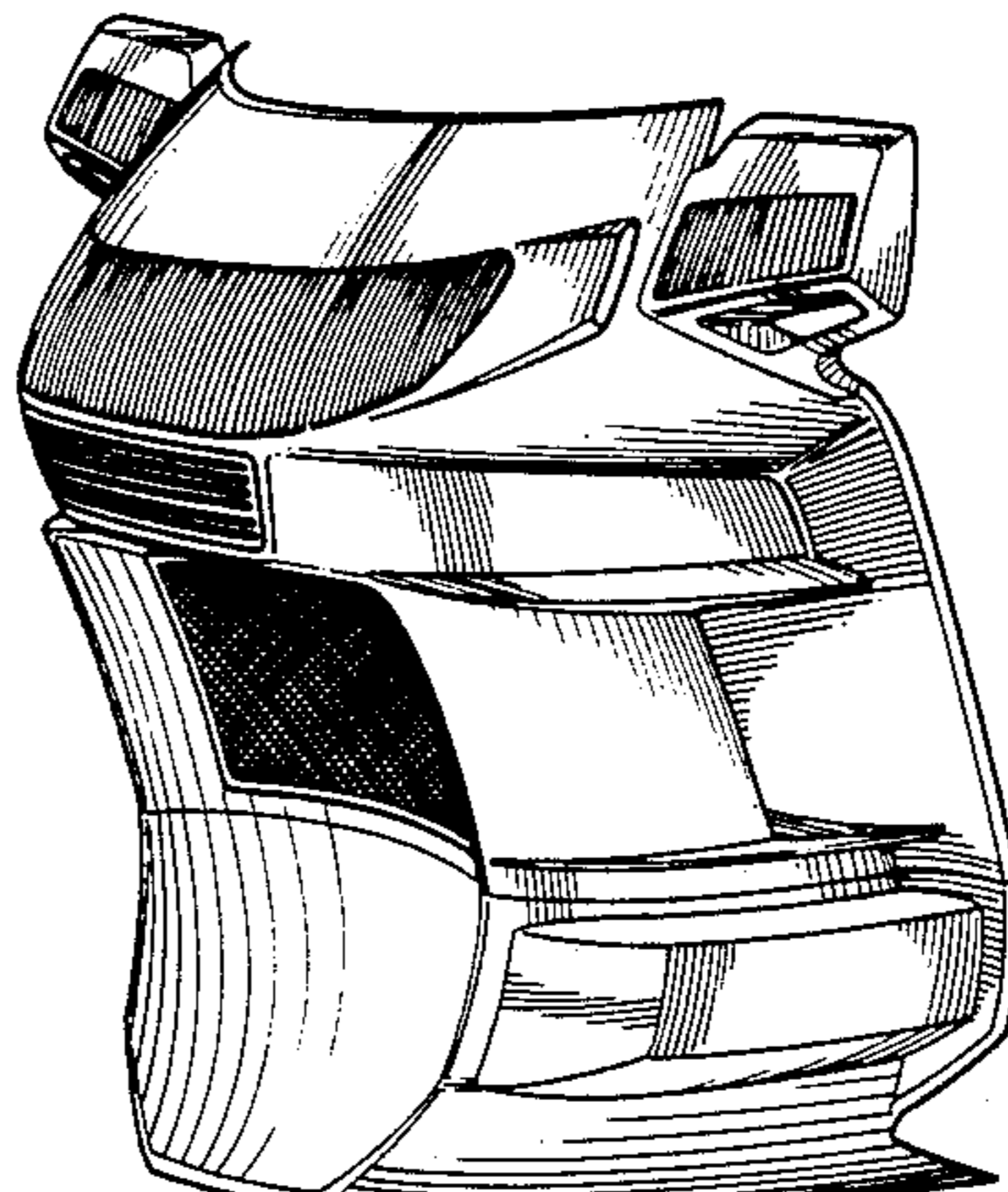
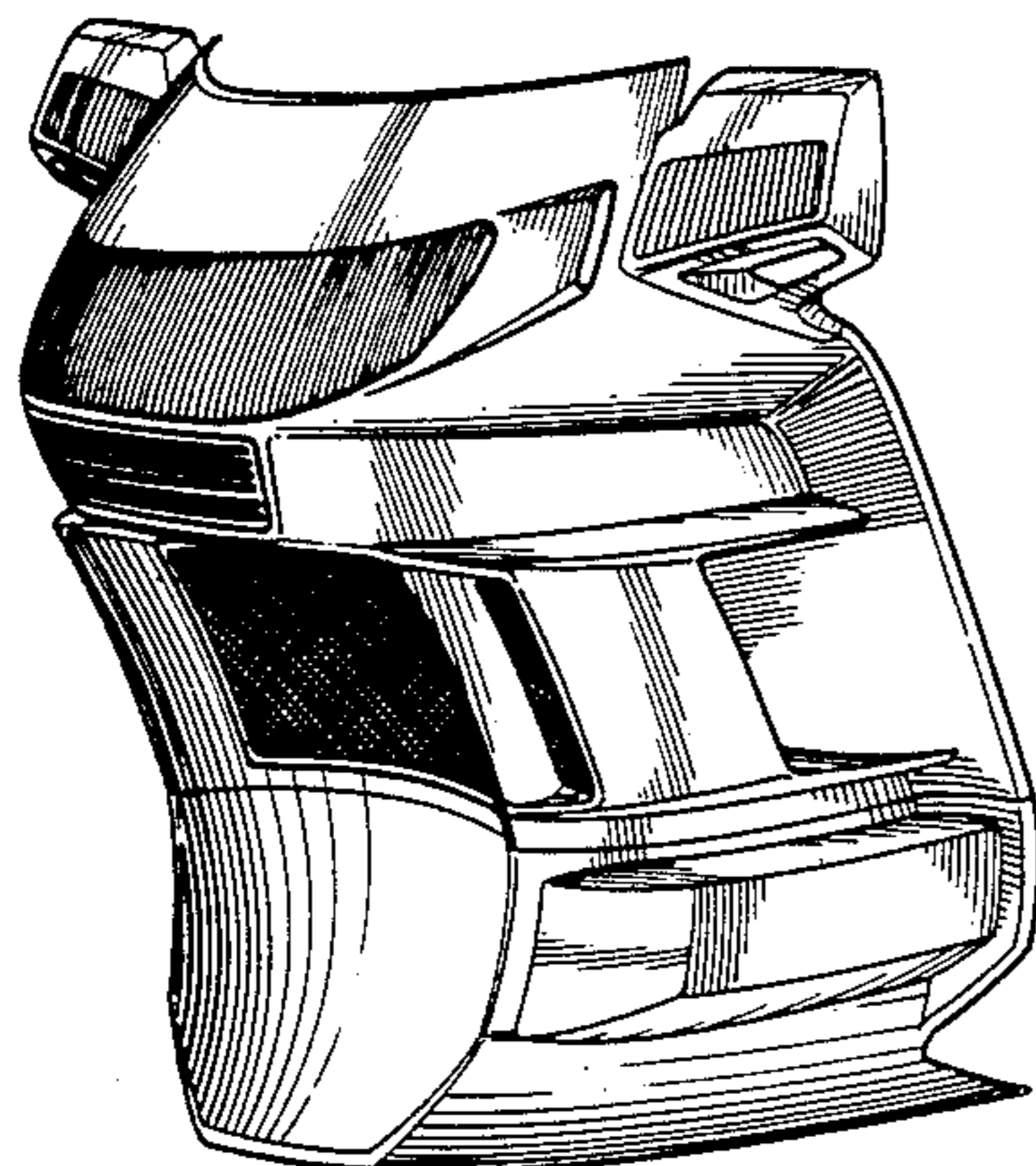
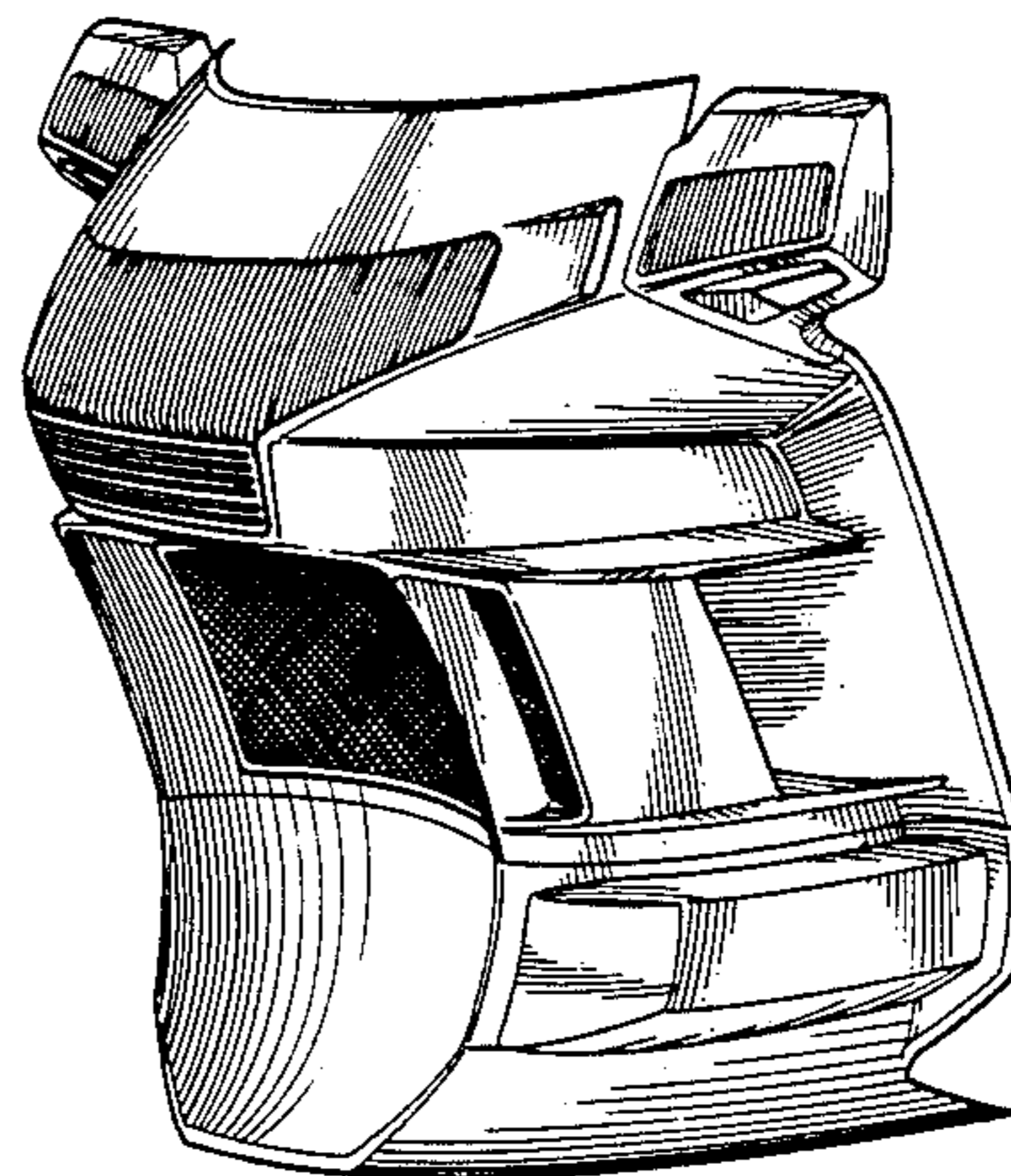
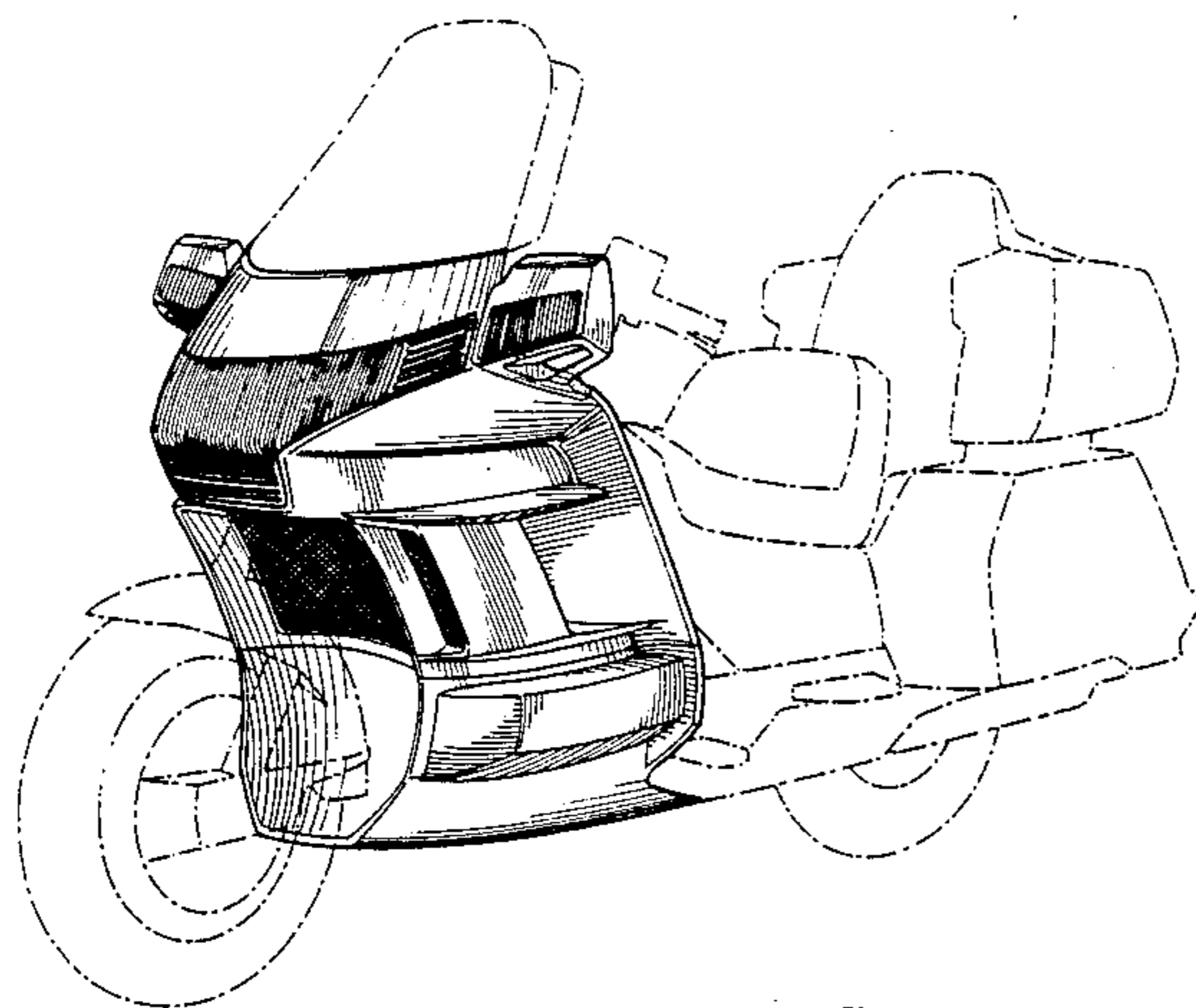

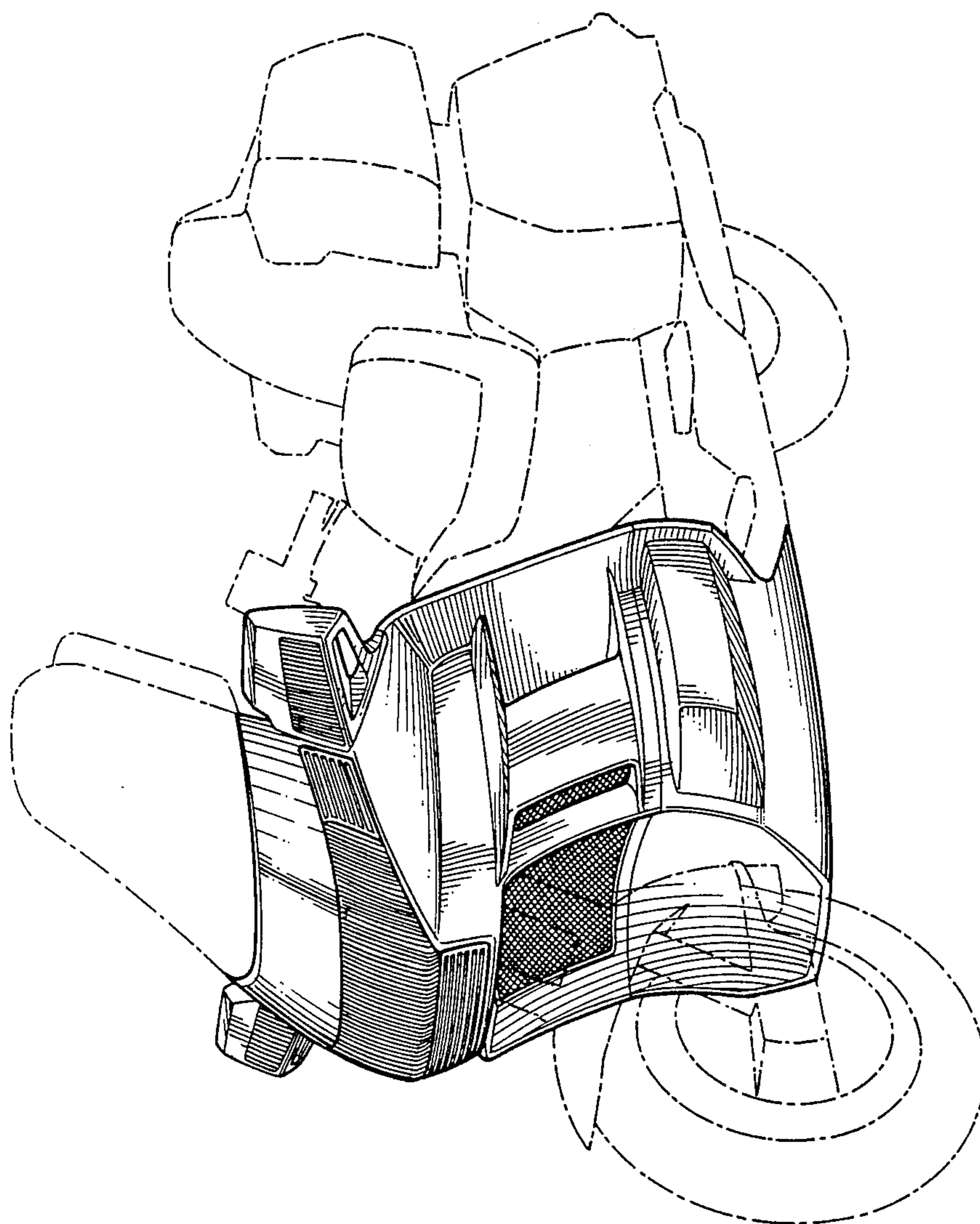

FIG. 1.

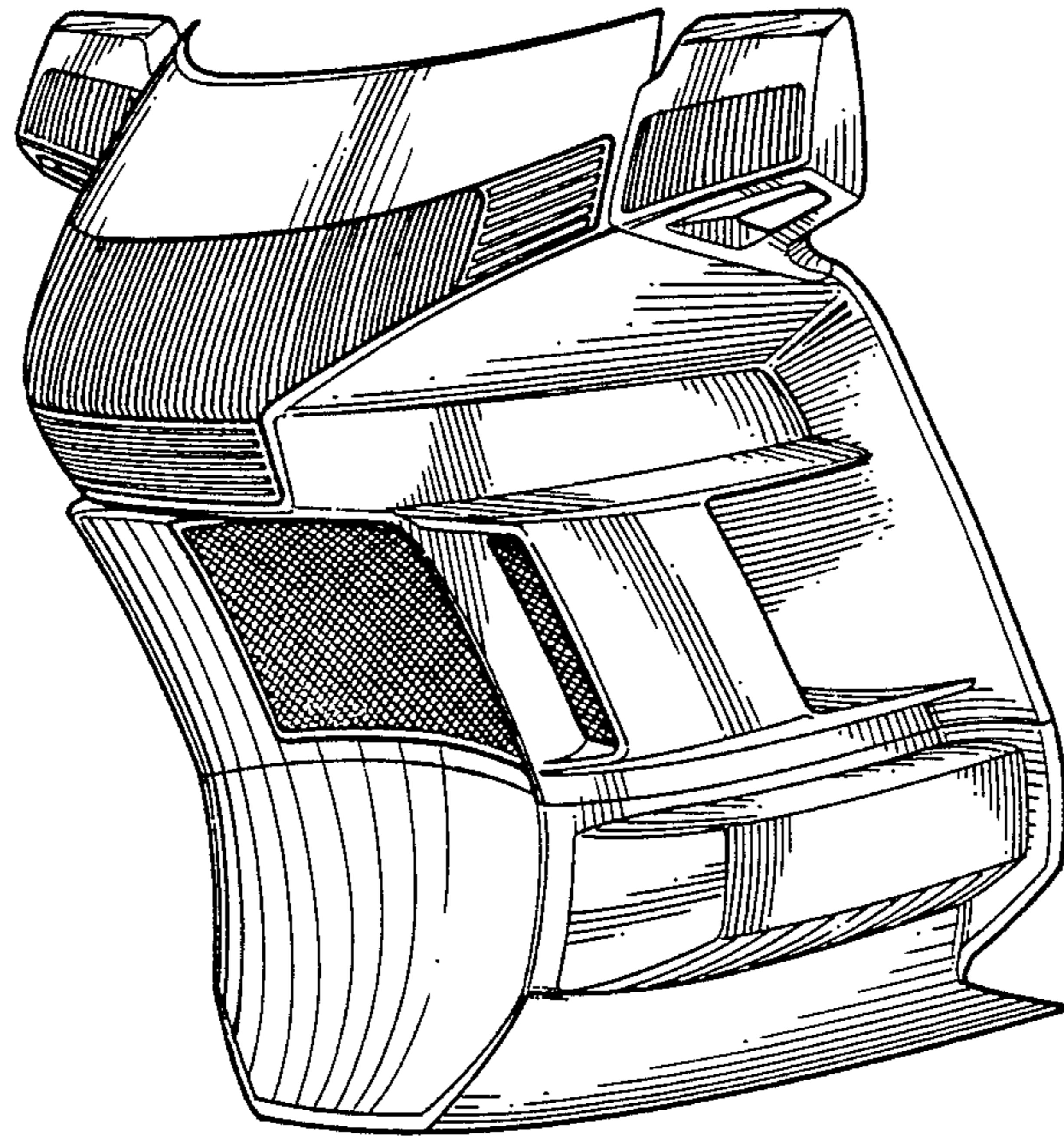

FIG. 2 .

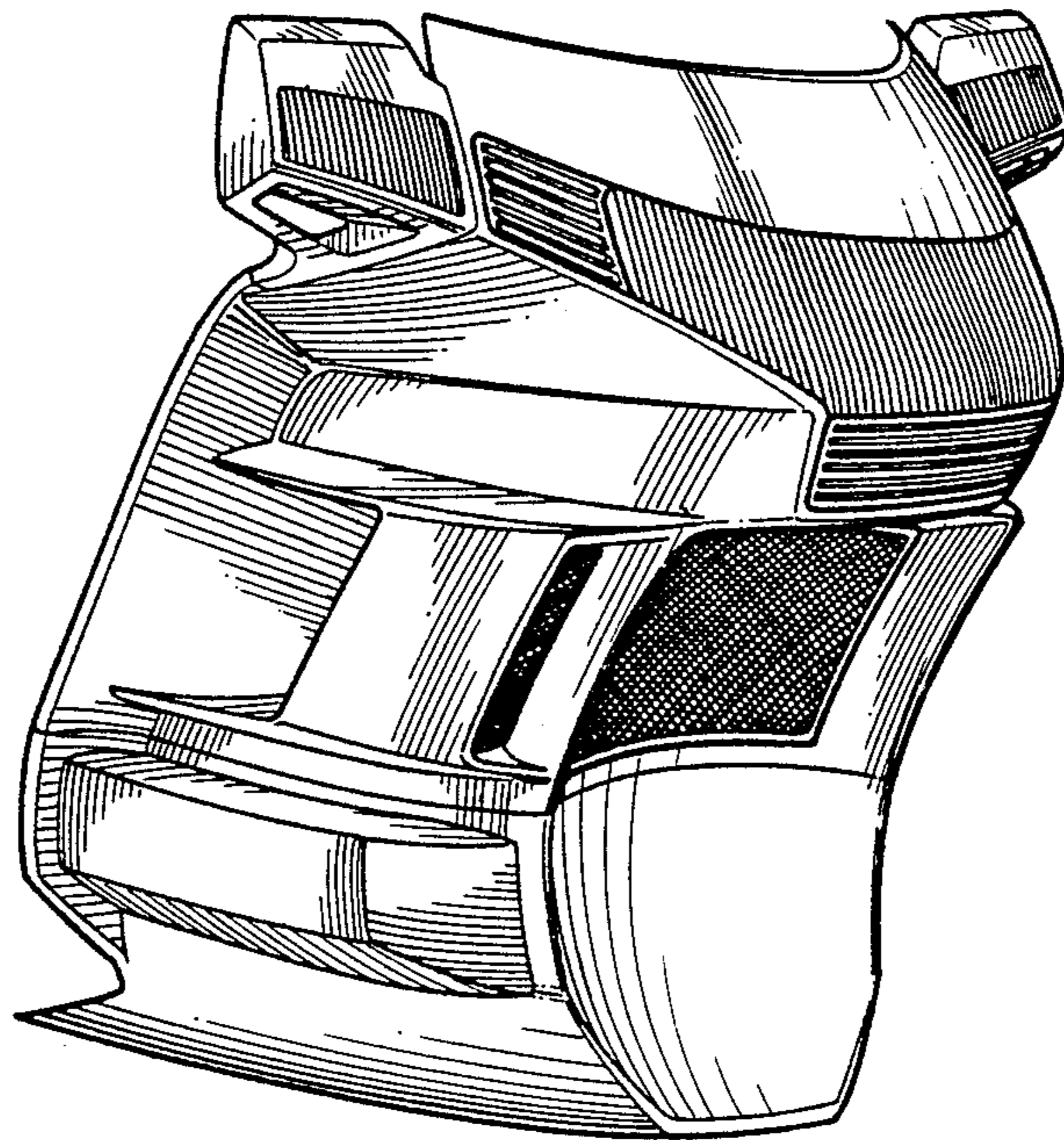

FIG. 3.

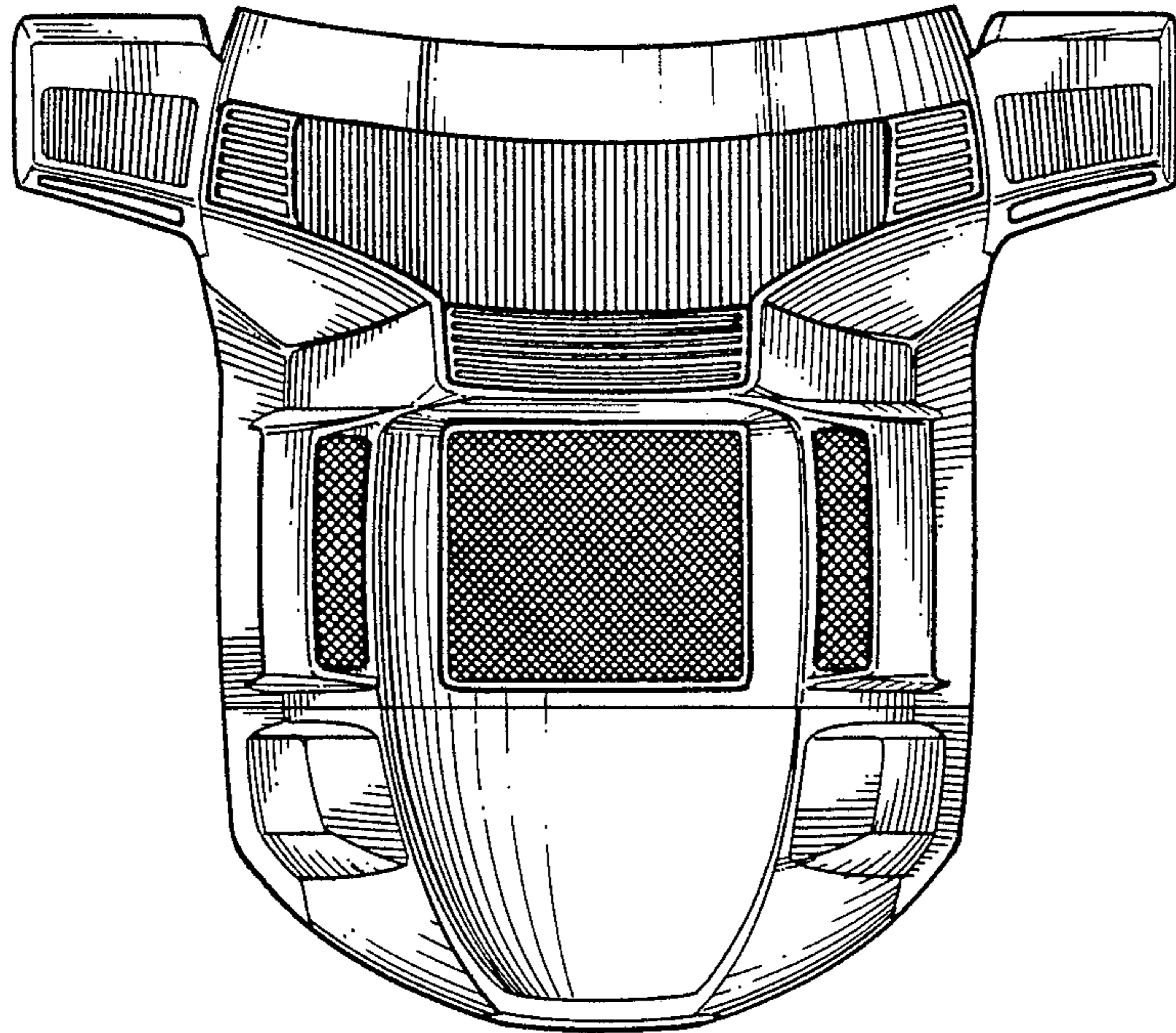

FIG. 4.

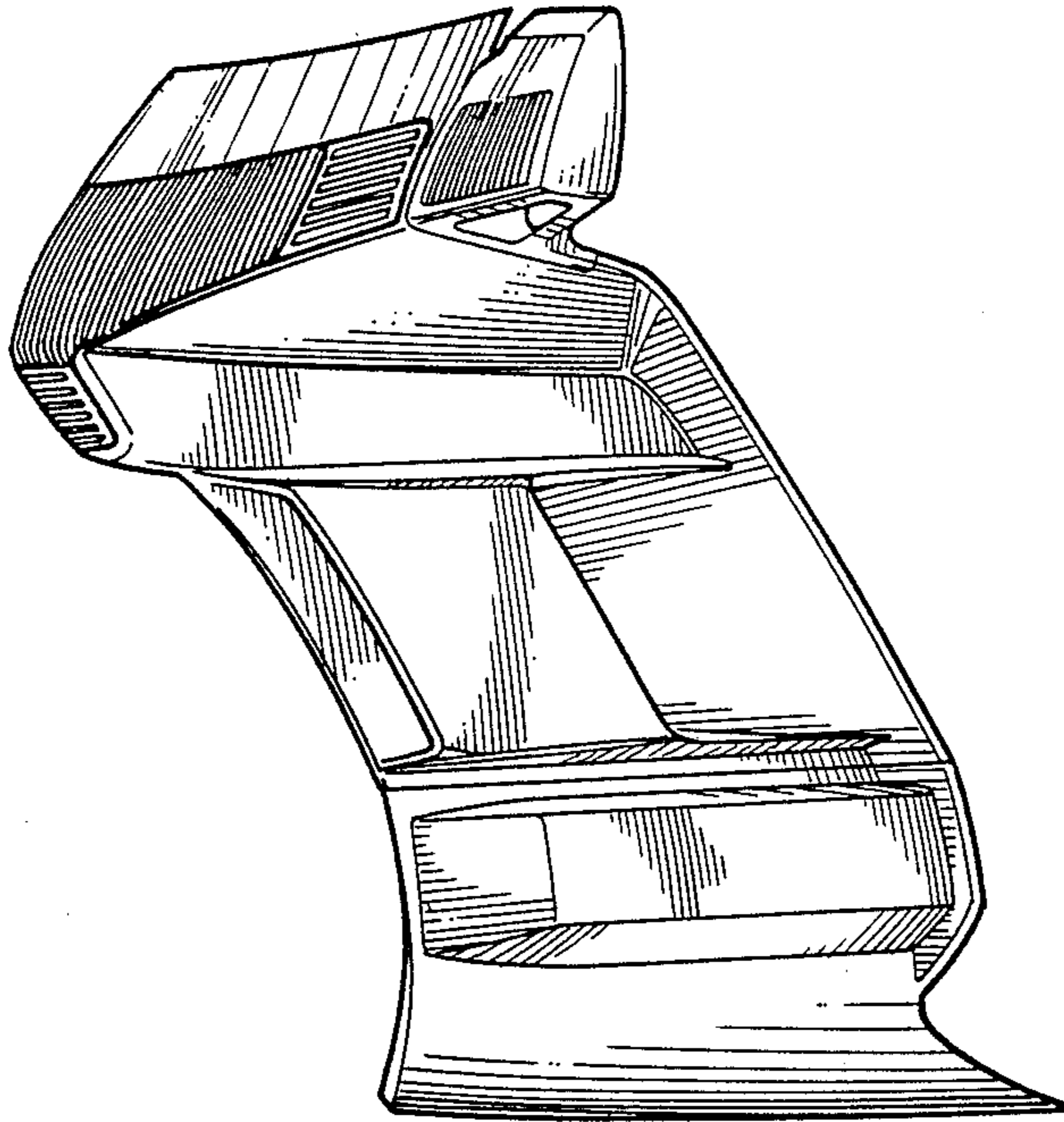

FIG. 5.

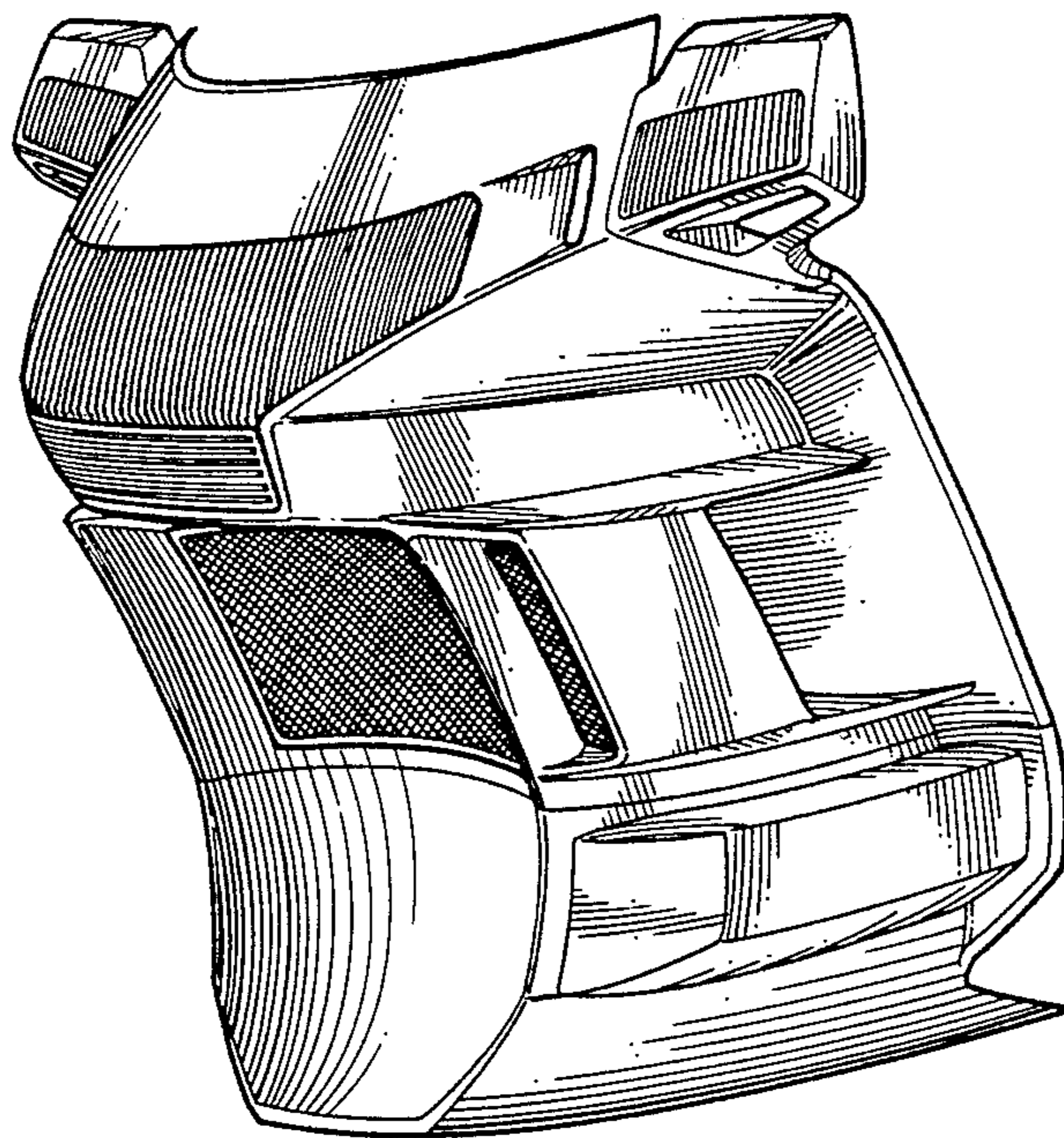

FIG. 6.

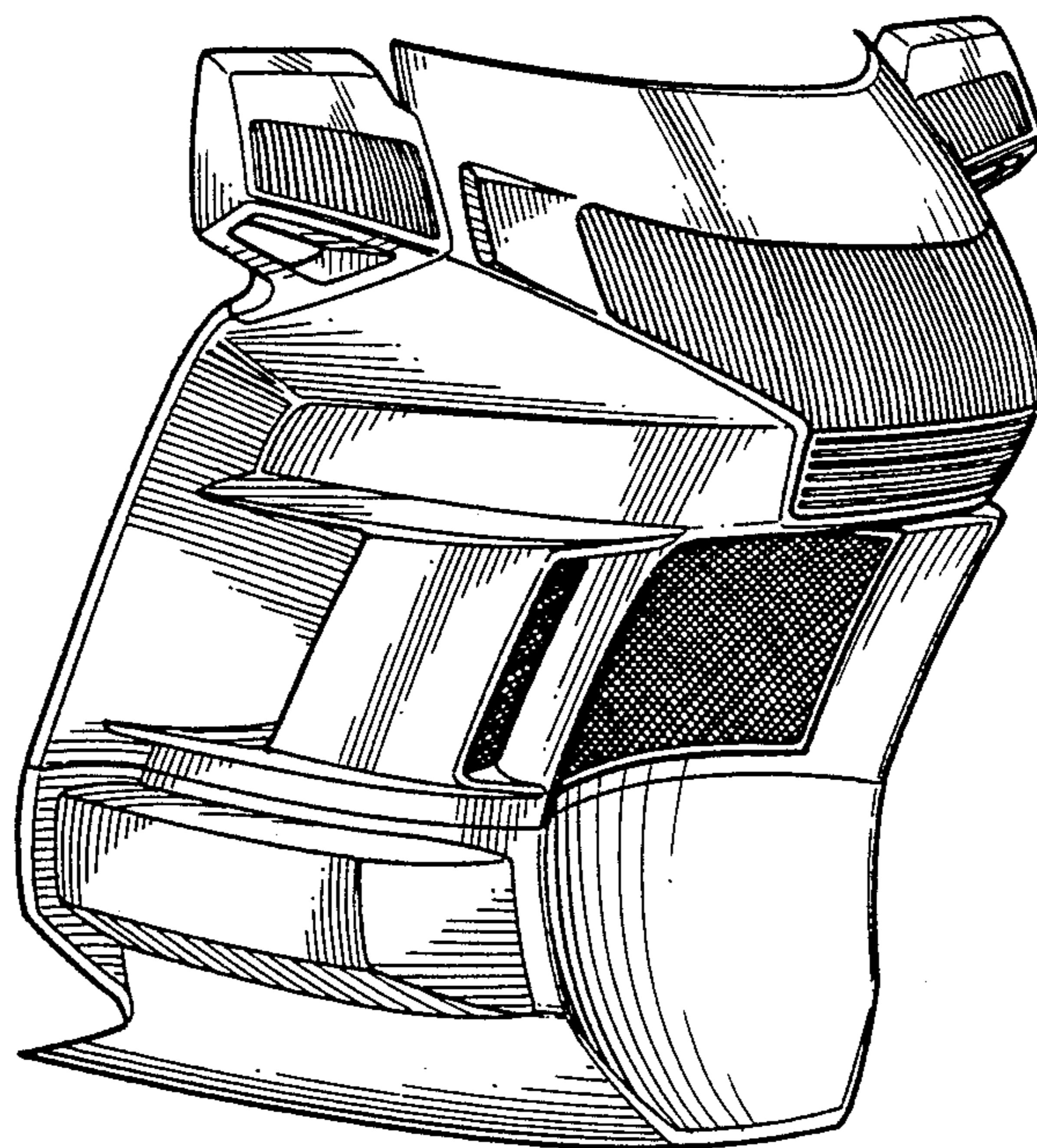

FIG. 7.

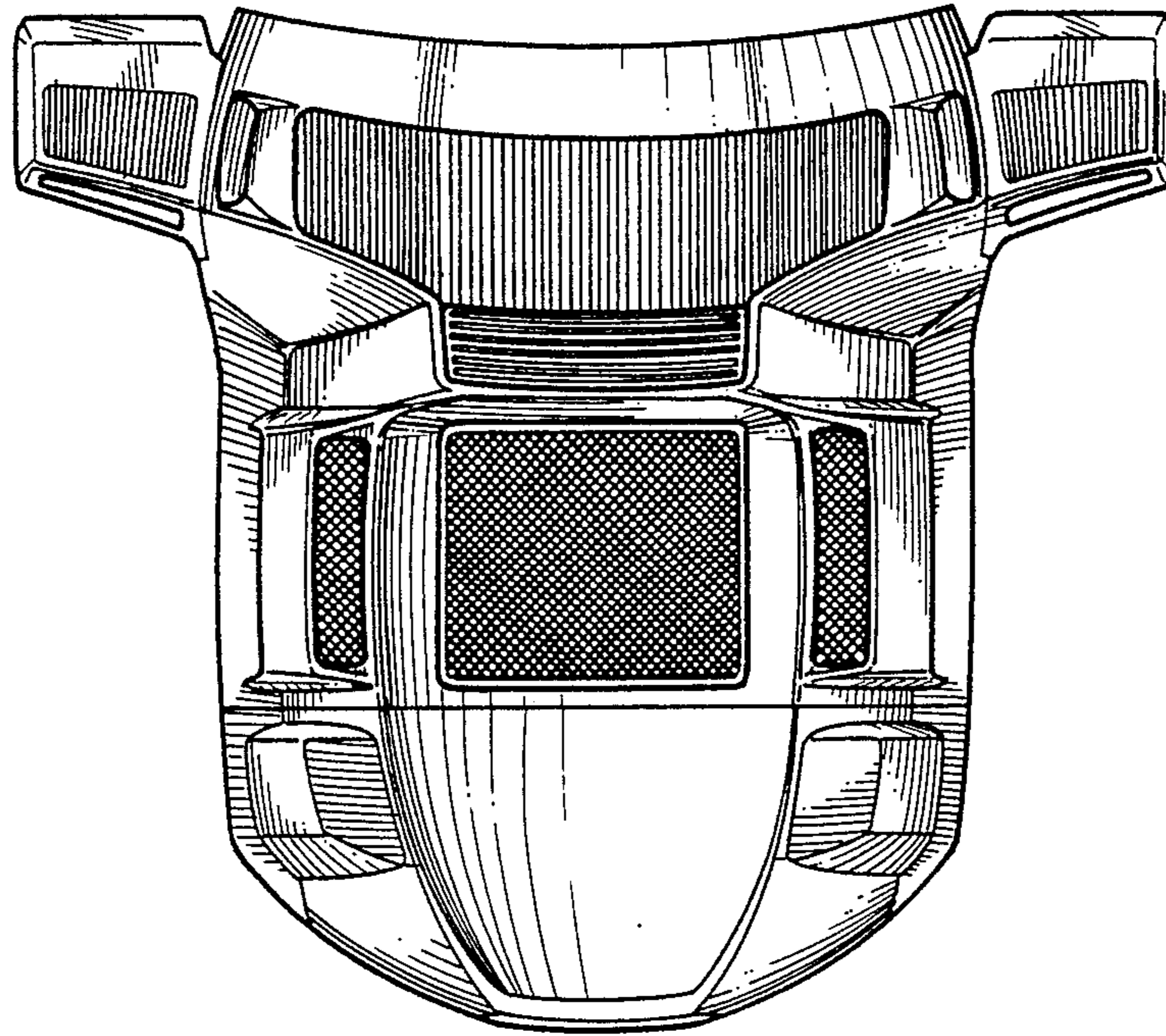

FIG. 8.

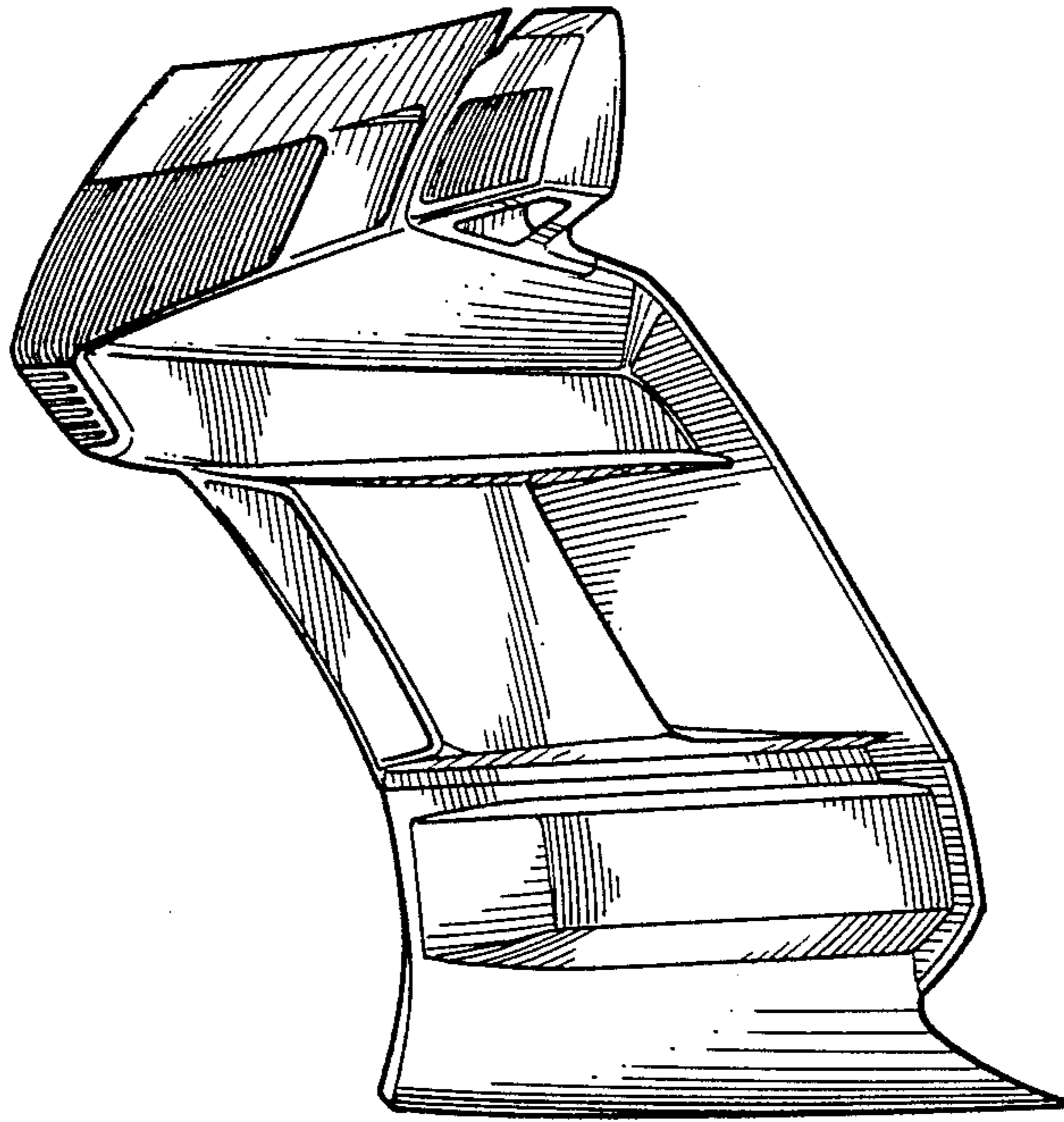

FIG. 9.

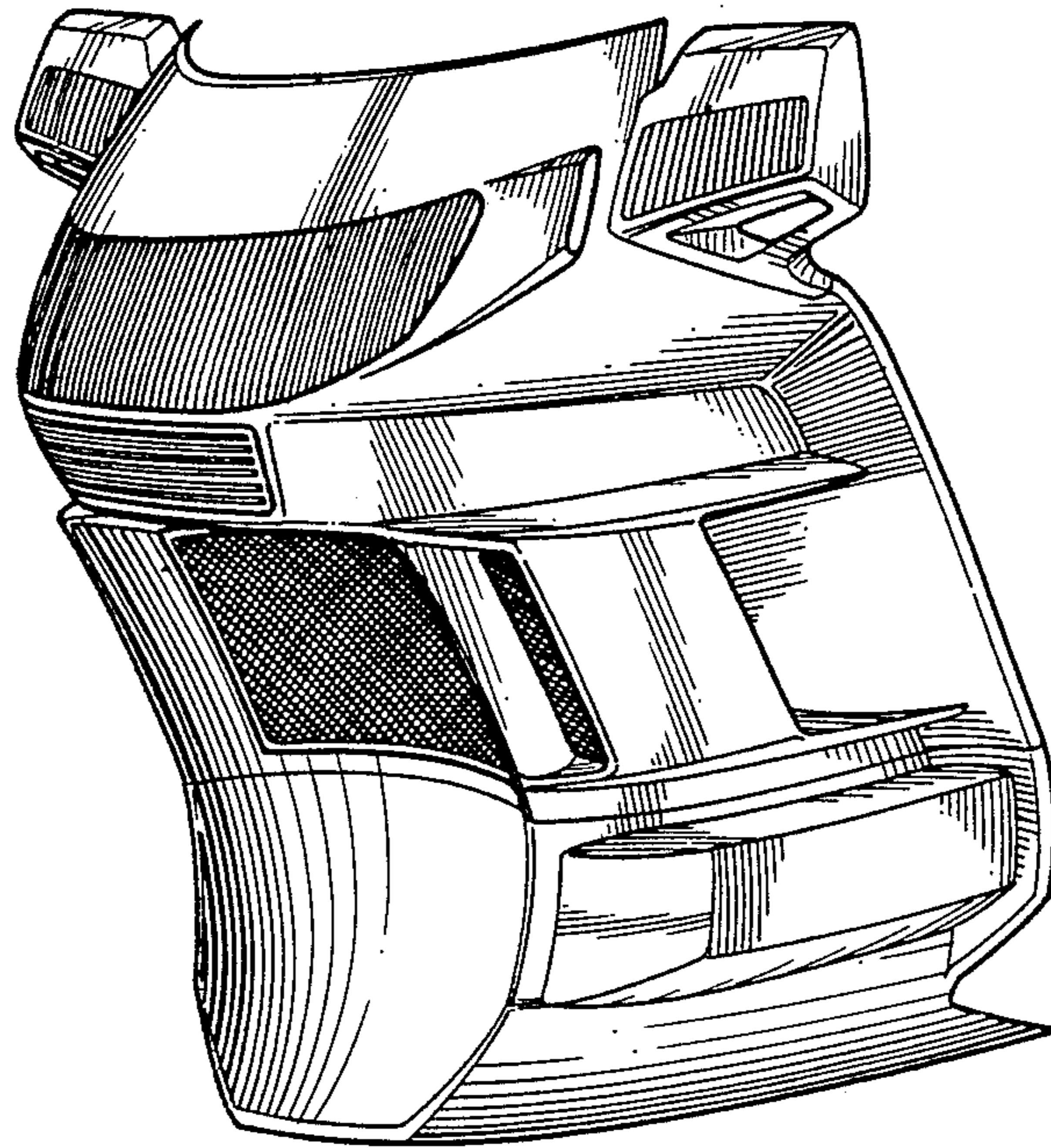

FIG. 10.

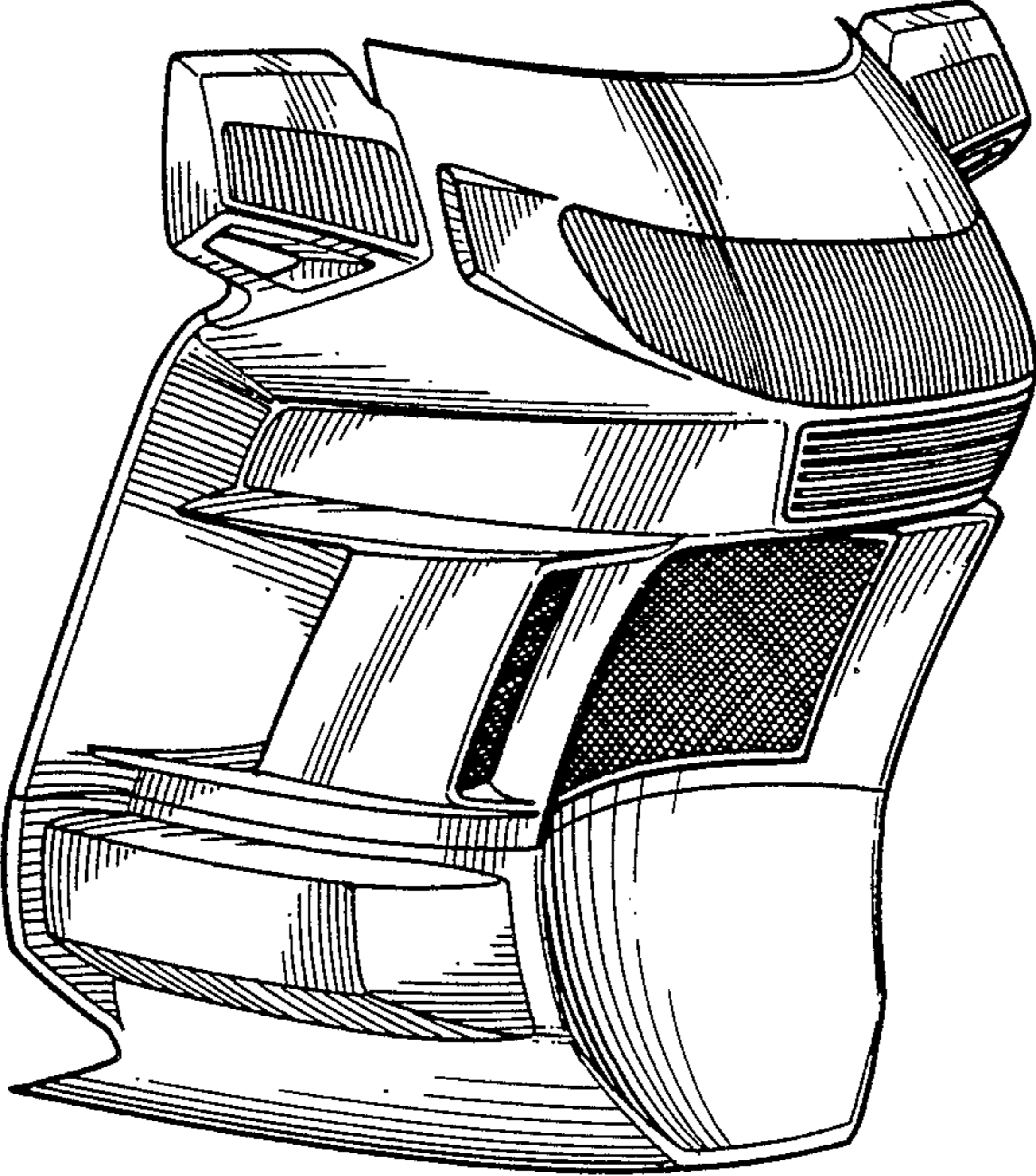

FIG. 11.

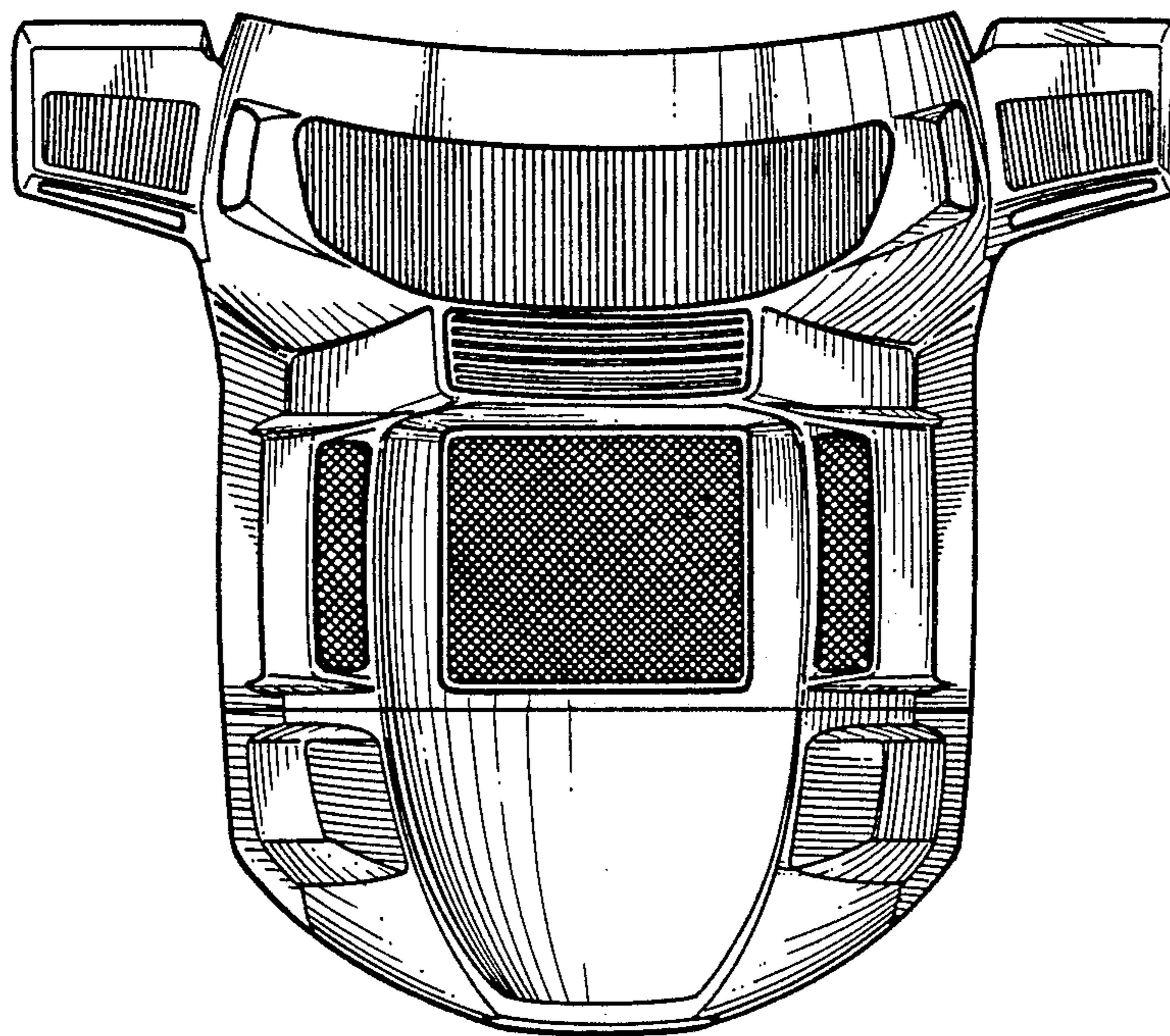

FIG. 12.

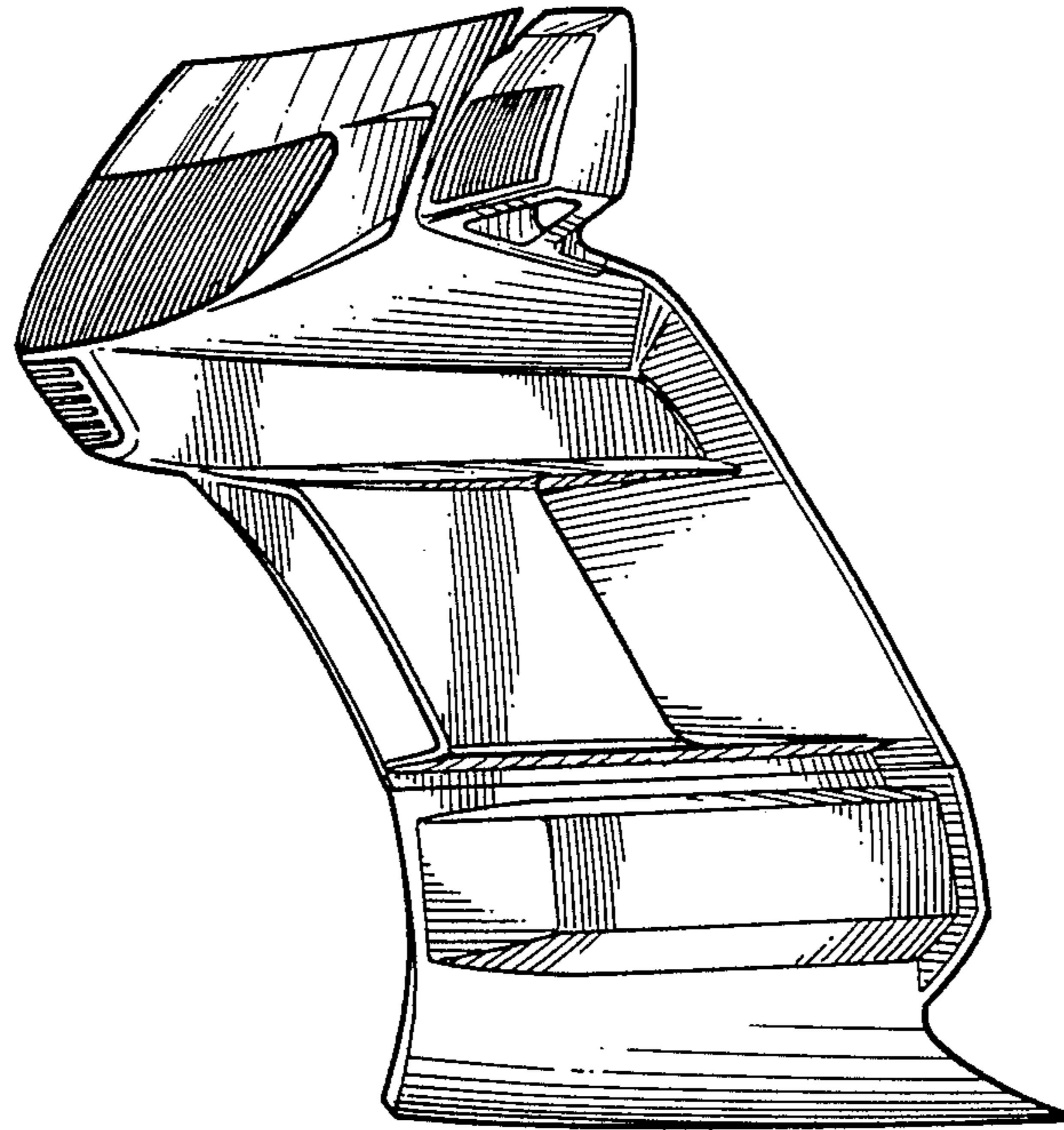

FIG. 13.

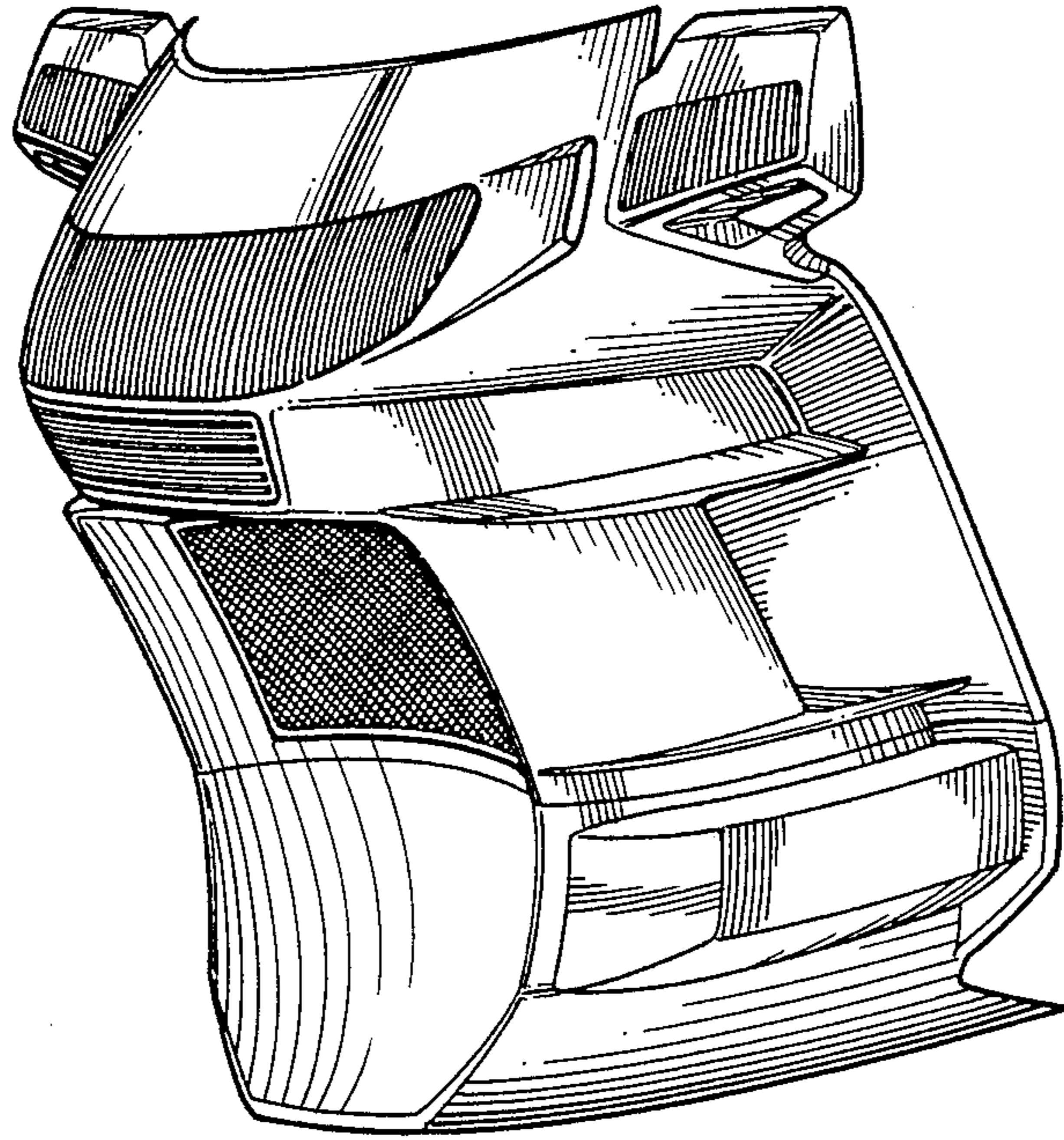

FIG. 14.

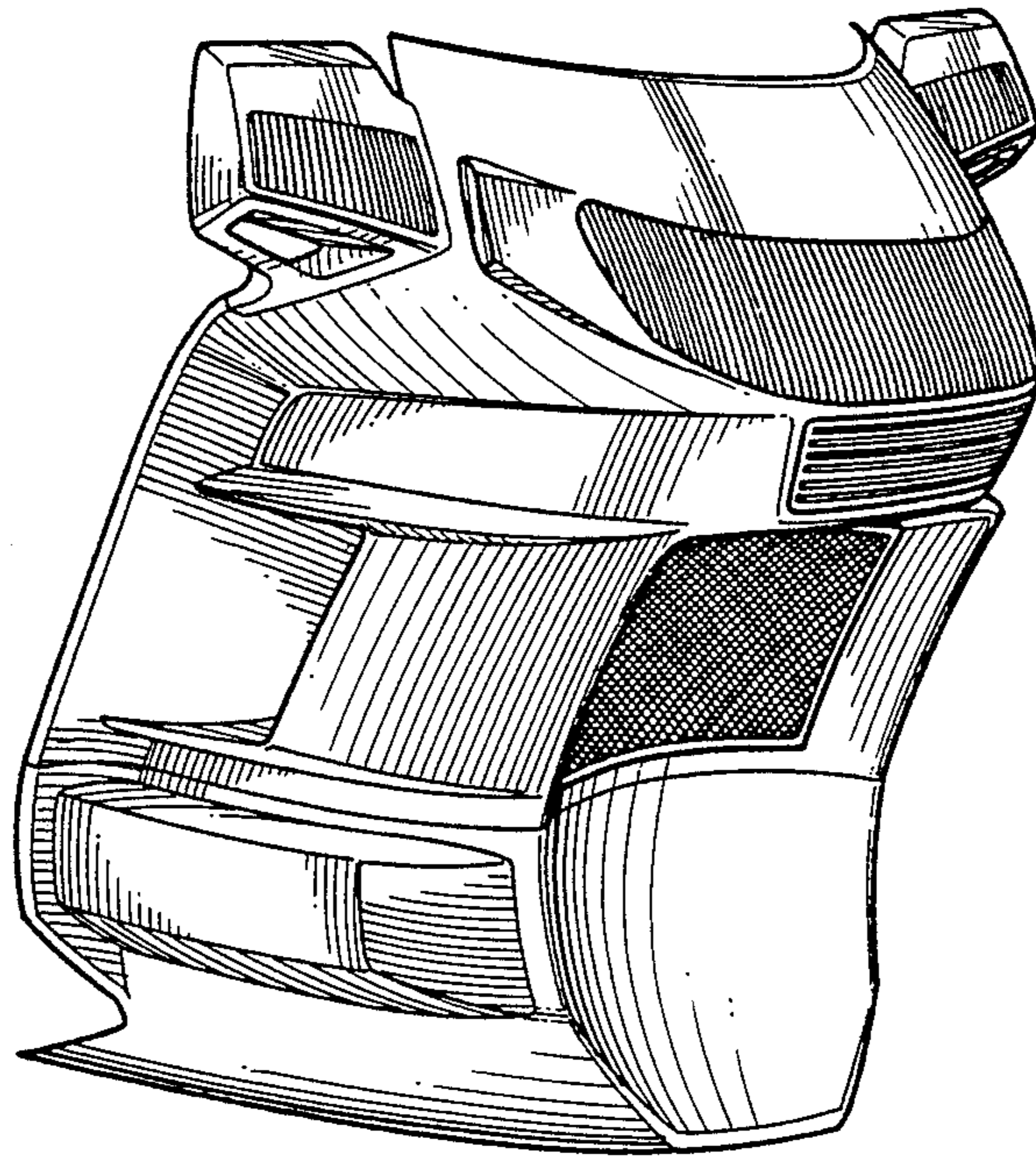

FIG. 15.

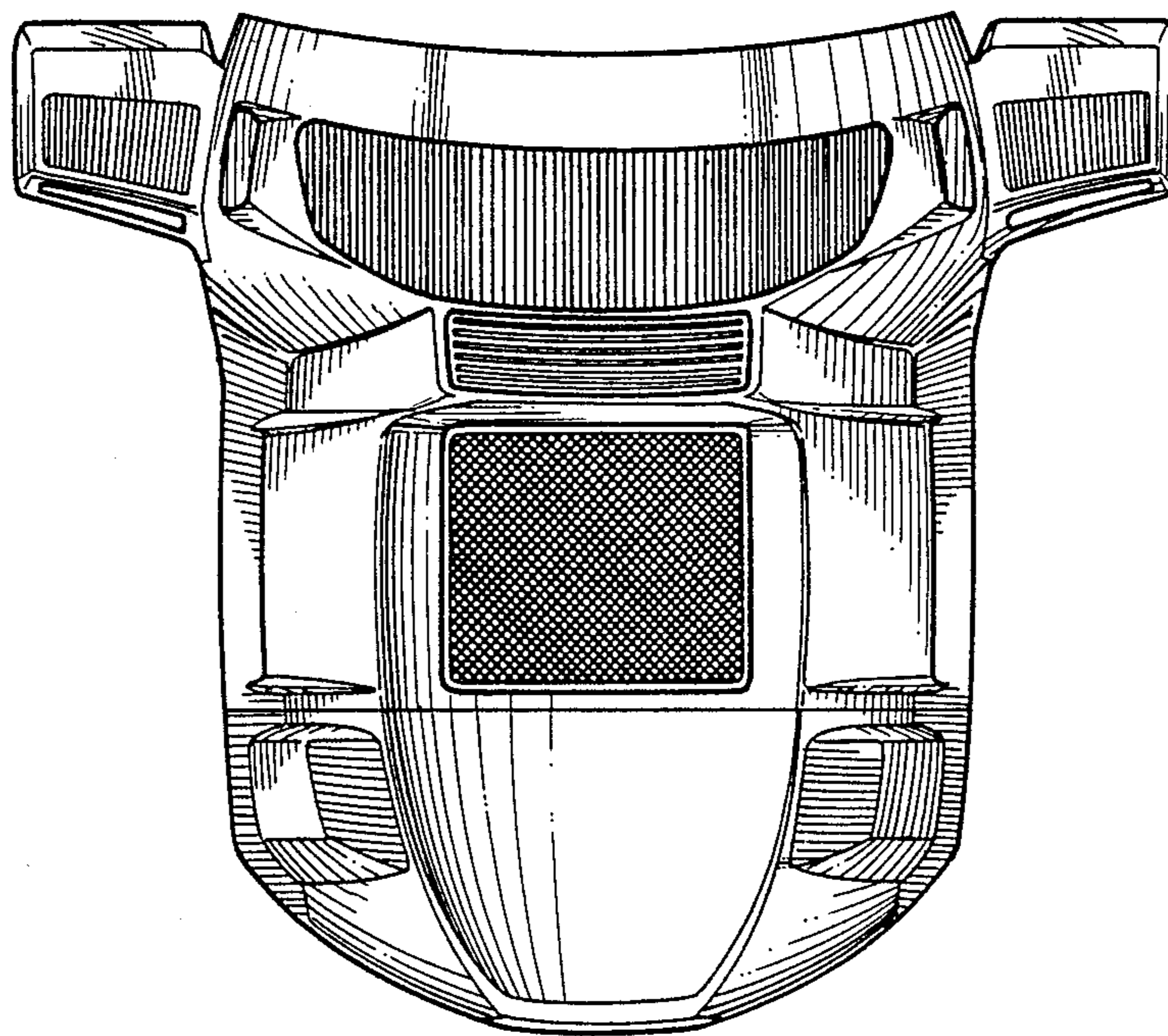

FIG. 16.

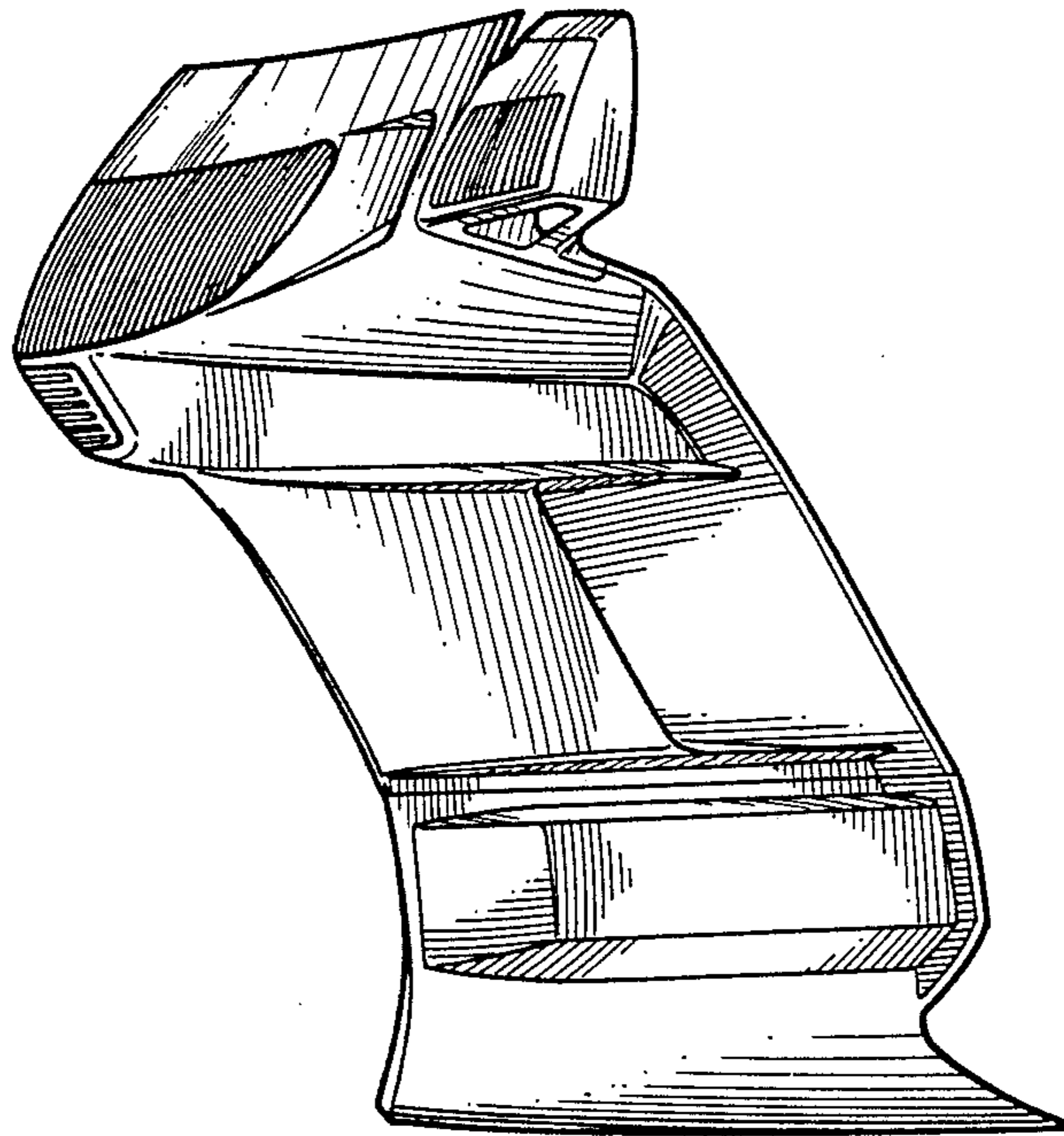

FIG. 17.