

[54] COMBINATION AUXILIARY BRAKE LIGHT AND CARGO LAMP FOR VEHICLES

[75] Inventors: Bradley C. VanRiper, Kennedy; Marlin Ong, Lakewood, both of N.Y.

[73] Assignee: Truck-Lite Co., Inc., Falconer, N.Y.

[**] Term: 14 Years

[21] Appl. No.: 222,227

[22] Filed: Jul. 21, 1988

[52] U.S. Cl. D26/35

[58] Field of Search D26/28-36, D26/120, 121, 122; 362/61, 74, 80, 80.1, 80.2, 82, 83, 83.2, 83.3, 362; 340/471-479, 468

[56] References Cited
U.S. PATENT DOCUMENTS

D. 247,991	5/1978	Tixier	D26/122
D. 279,927	7/1985	Preisler et al.	D26/35
4,554,617	11/1985	Tyler	362/61
4,628,417	12/1986	Kaminski et al.	362/80 X

FOREIGN PATENT DOCUMENTS

2811286 9/1979 Fed. Rep. of Germany 362/61

Primary Examiner—Susan J. Lucas
Attorney, Agent, or Firm—Mason, Fenwick & Lawrence

[57] CLAIM

The ornamental design for a combination auxiliary brake light and cargo lamp for vehicles, as shown and described.

DESCRIPTION

FIG. 1 is a side elevational view of a combination auxiliary brake light and cargo lamp for vehicles showing our new design;
 FIG. 2 is a front elevational view thereof;
 FIG. 3 is a top plan view thereof;
 FIG. 4 is a bottom plan view thereof;
 FIG. 5 is a vertical section view taken along the line 5—5 of FIG. 3;
 FIG. 6 is a vertical section view taken along the line 6—6 of FIG. 3; and
 FIG. 7 is a rear elevational view thereof.
 FIG. 8 is a bottom, front perspective view thereof on a reduced scale.

A portion of a vehicle roof in FIG. 1 and the end caps on the lamp bases in FIGS. 1 and 3 through 8 are shown in broken lines for illustrative purposes only.

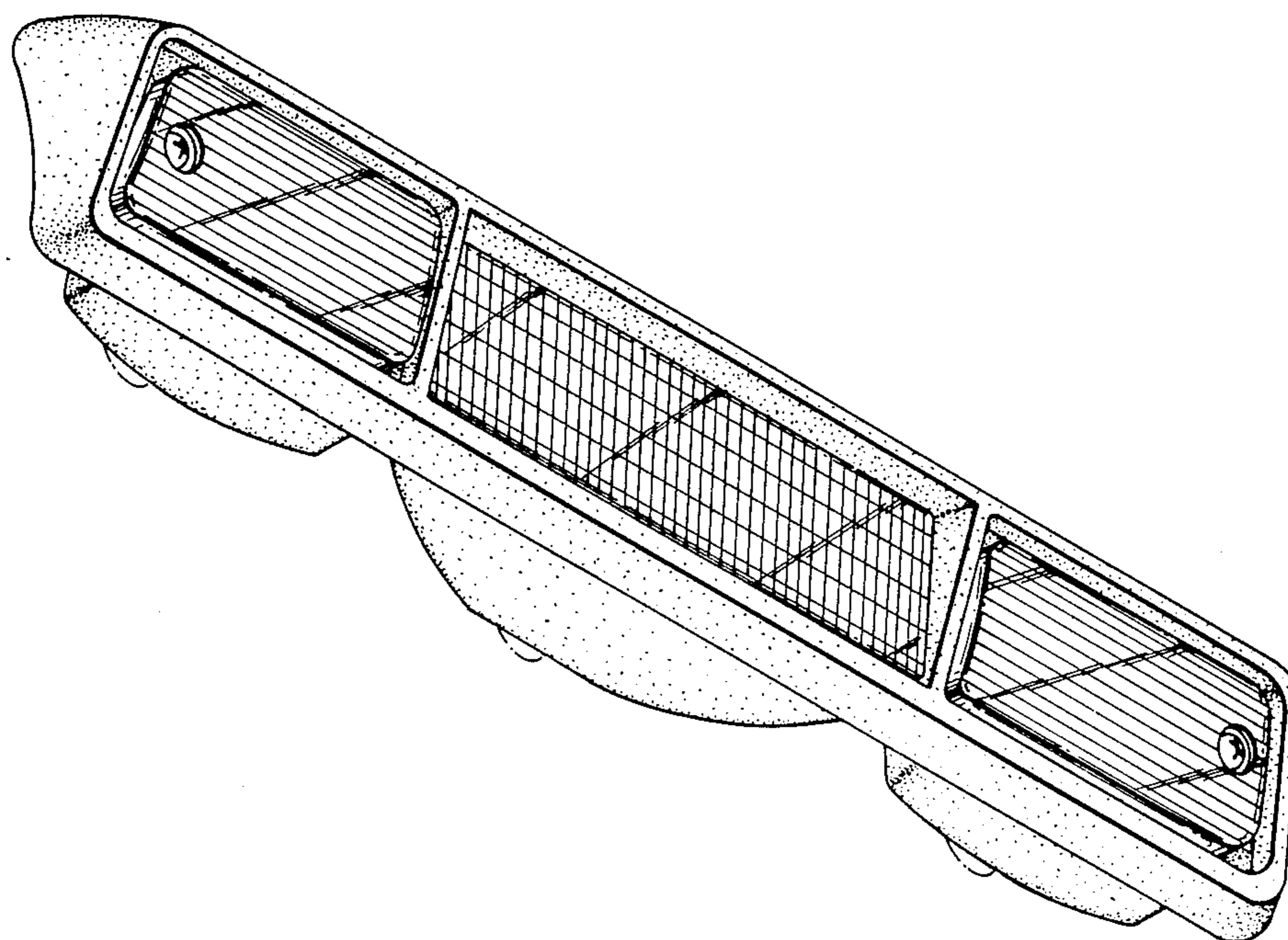

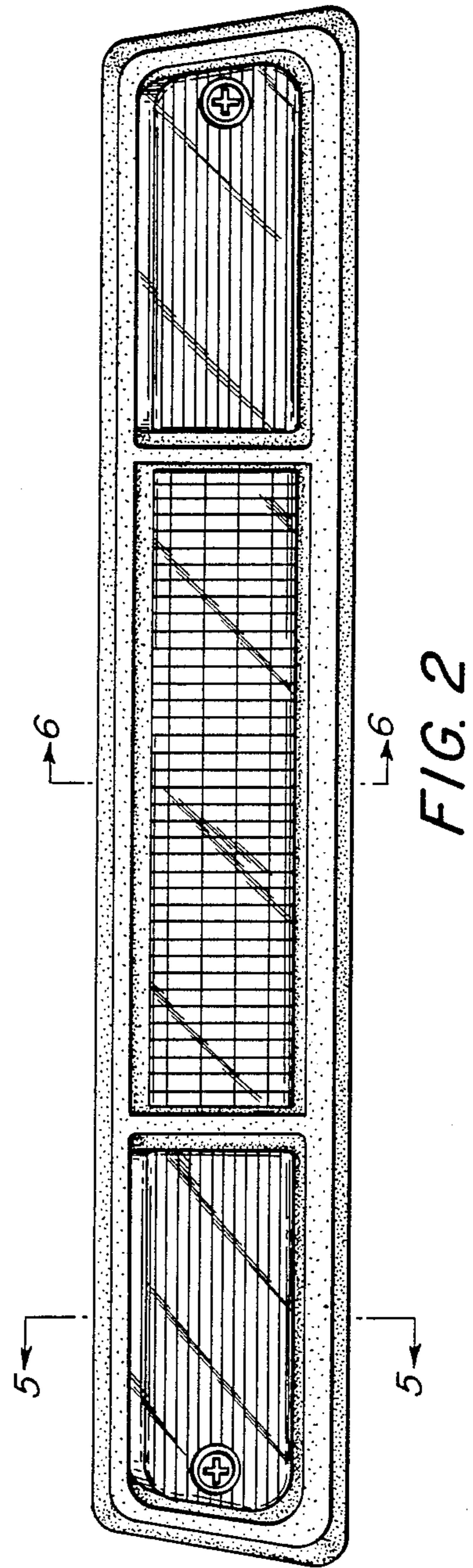
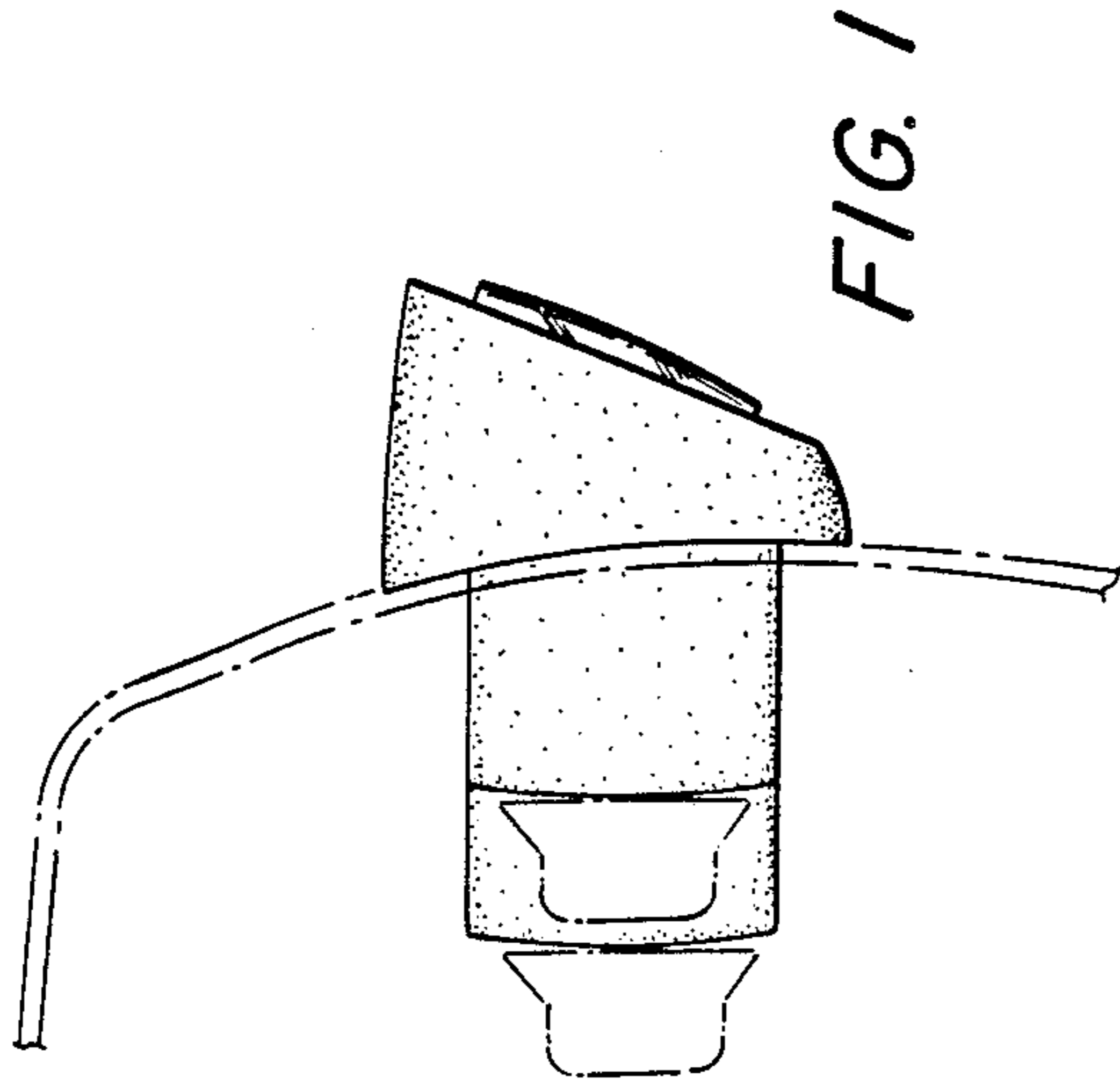

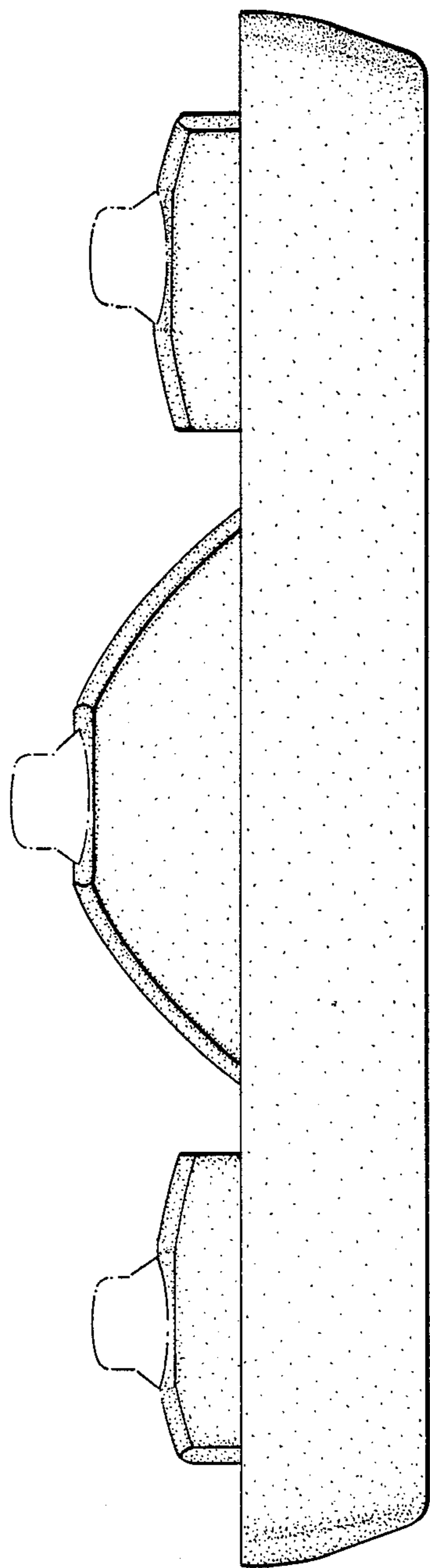
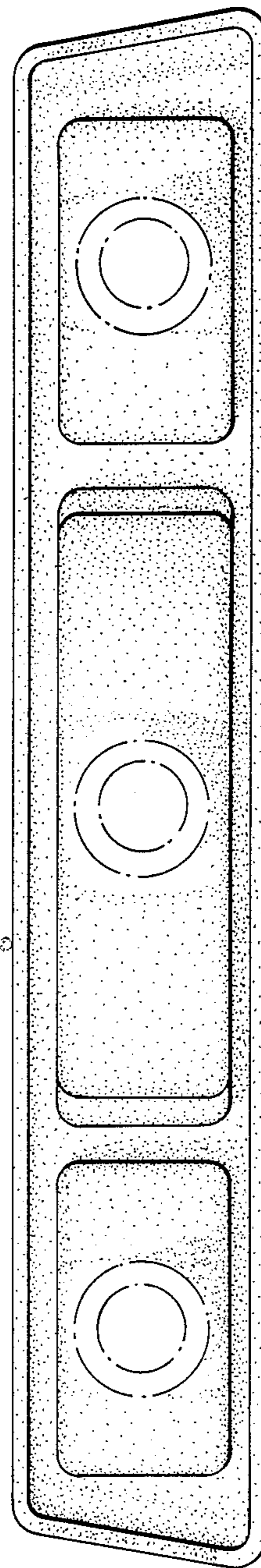

FIG. 3

FIG. 7



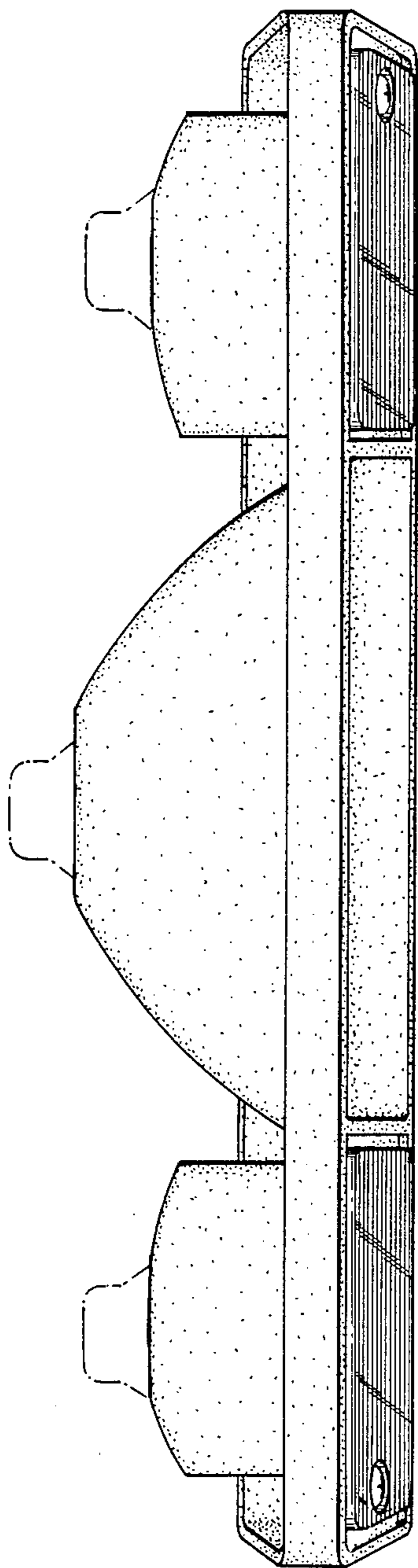

FIG. 4

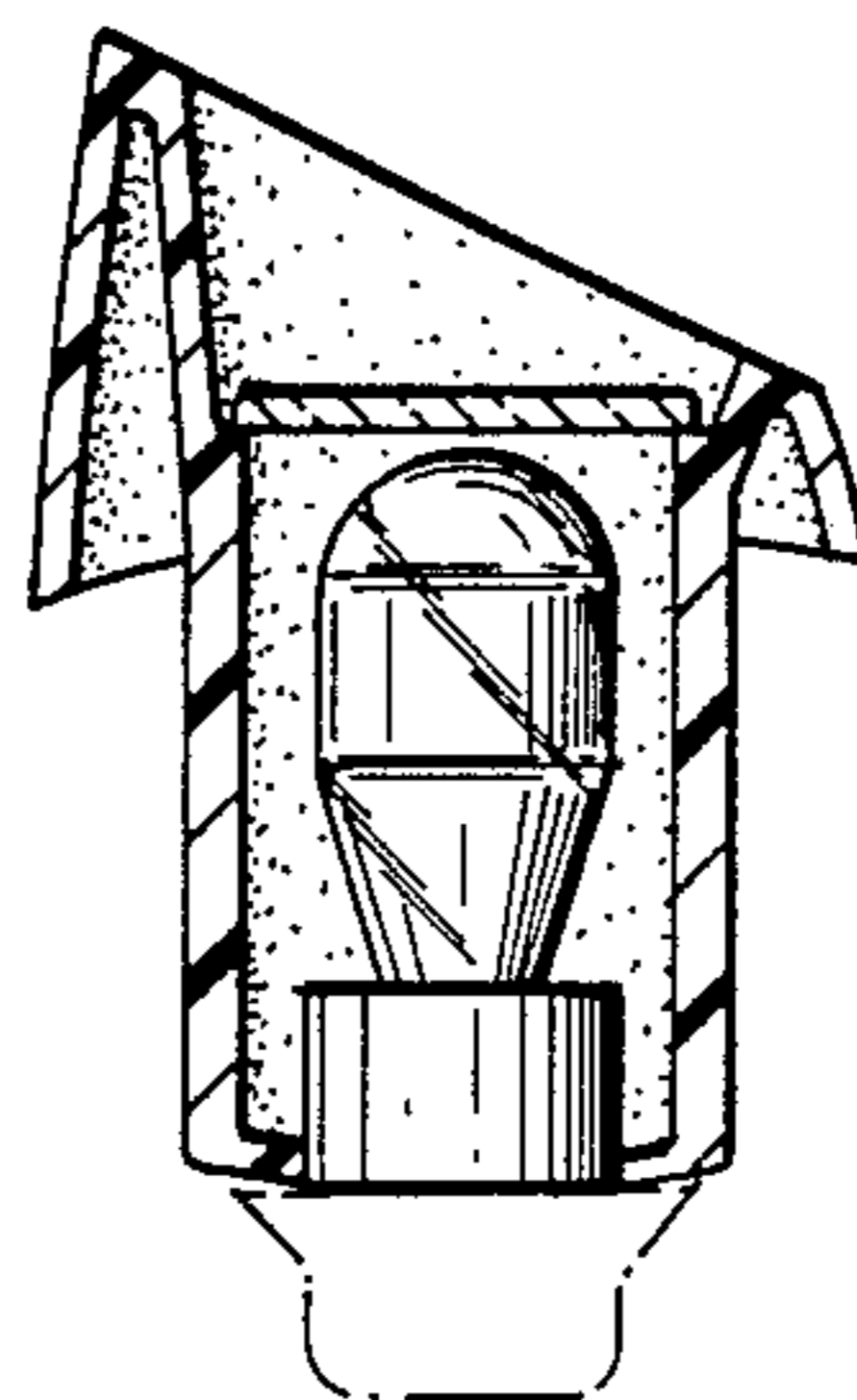

FIG. 6

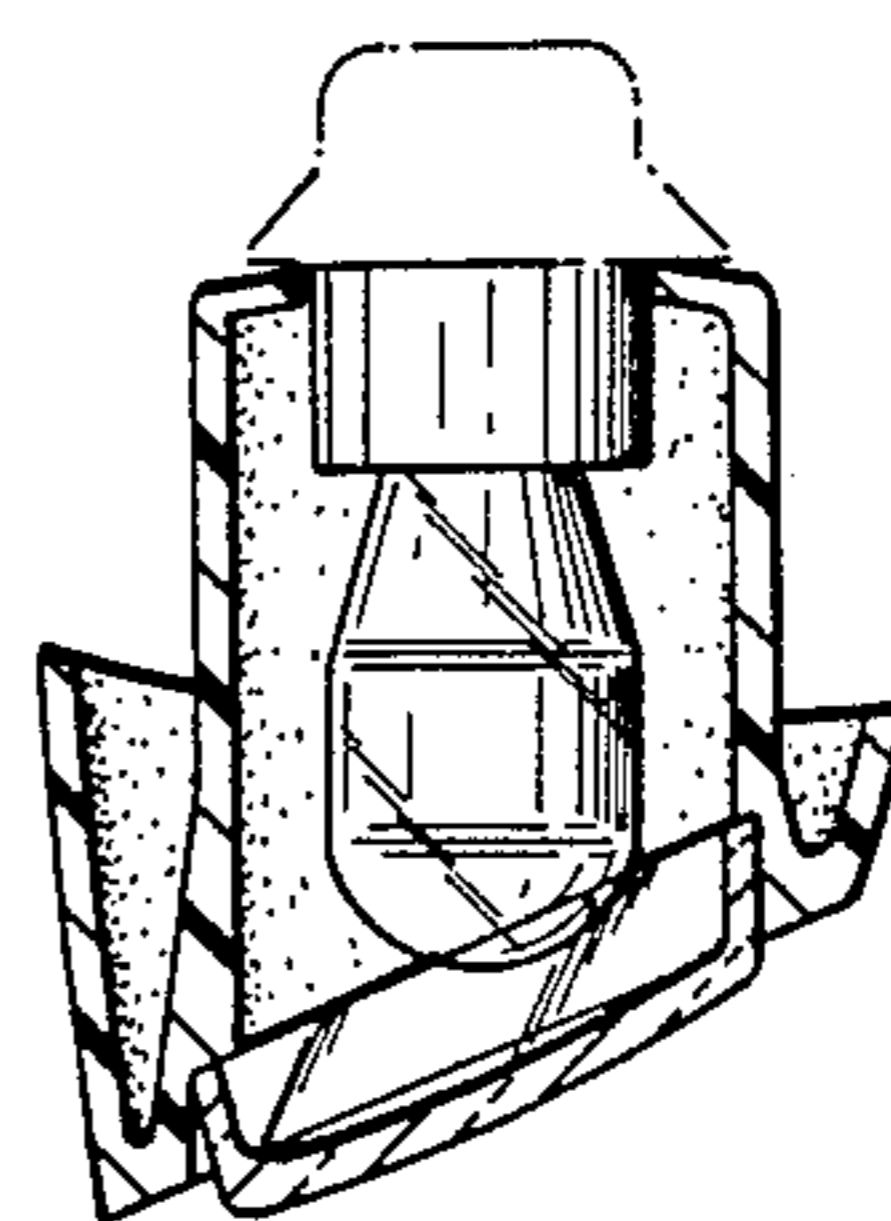

FIG. 5

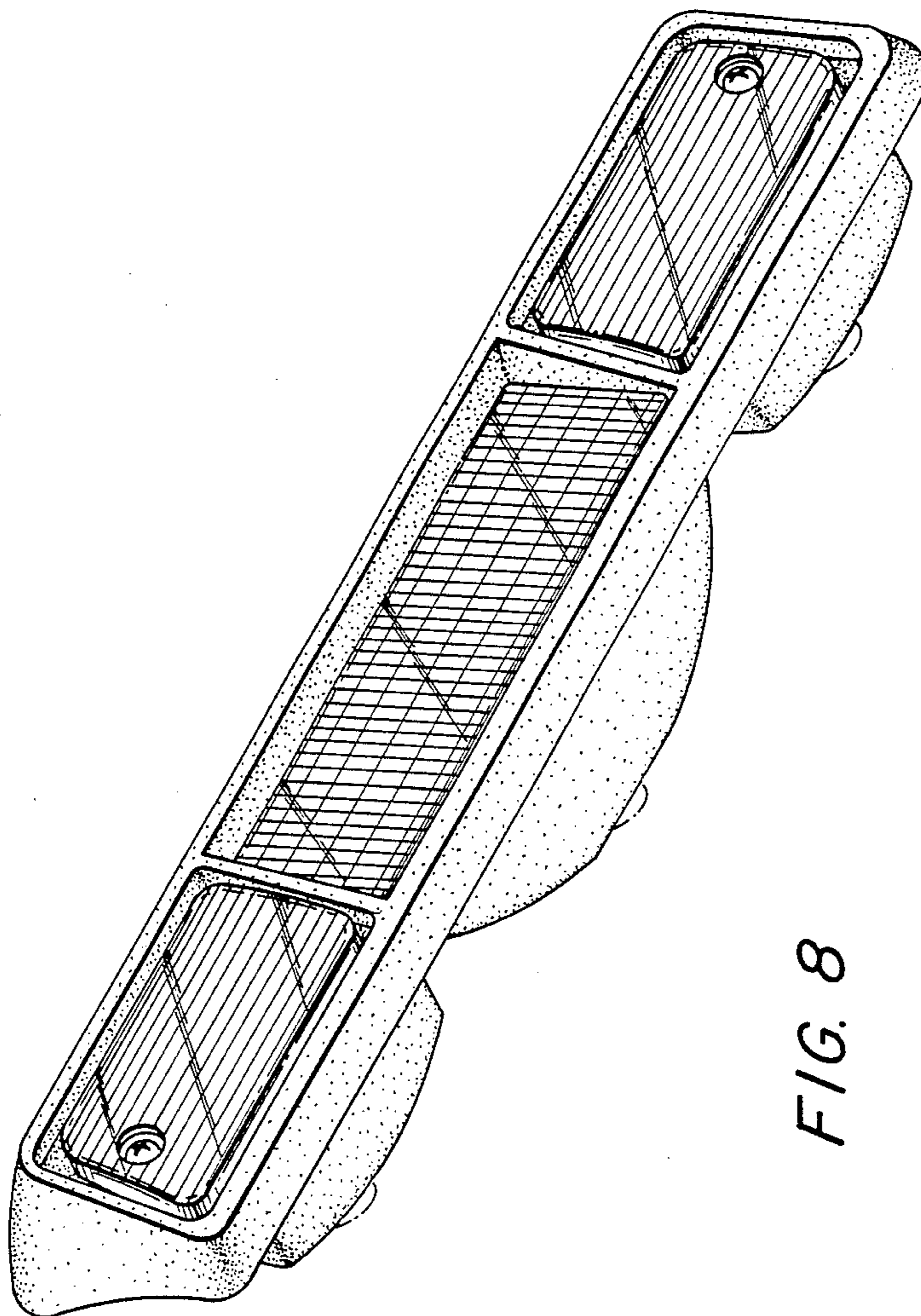

FIG. 8