

United States Patent [19]

Sano et al.

[11] Patent Number: **Des. 311,514**

[45] Date of Patent: **** Oct. 23, 1990**

[54] **LIGHT AIR PLANE**

[75] Inventors: **Isao Sano; Michiyoshi Shiraishi**, both of Tokyo, Japan

[73] Assignee: **Nissan Motor Co., Ltd.**, Yokohama, Japan

[**] Term: **14 Years**

[21] Appl. No.: **189,747**

[22] Filed: **May 3, 1988**

[30] **Foreign Application Priority Data**

Mar. 31, 1988 [JP] Japan 63-13038

[52] U.S. Cl. **D12/337; D12/319; D12/326**

[58] **Field of Search** D12/321, 339, 344, 319, D12/324, 326, 327, 328, 329, 331; 244/45 A, 45 R, 91, DIG. 1.4, 16, 13

[56] **References Cited**

U.S. PATENT DOCUMENTS

D. 178,584 8/1956 Toth D12/324
D. 211,215 5/1968 Girard D12/335

D. 219,844 2/1971 Biemond D12/337
D. 298,026 10/1988 Judge D12/319

OTHER PUBLICATIONS

Flight Int'l., Dec. 22 and 29, 1984, p. 1680, "Panther Plus".

Flight Int'l., Nov. 5, 1983, p. 1202, "De Vore", Ultra-light (bottom).

Primary Examiner—Kay H. Chin
Attorney, Agent, or Firm—Foley & Lardner, Schwartz, Jeffery, Schwaab, Mack, Blumenthal & Evans

[57] CLAIM

The ornamental design for a light air plane, as shown and described.

DESCRIPTION

FIG. 1 is a front and top perspective view of a light air plane showing our new design;
FIG. 2 is a front elevation view thereof;
FIG. 3 is a rear elevation view thereof;
FIG. 4 is a top plan view thereof;
FIG. 5 is a bottom plan view thereof;
FIG. 6 is a right side elevational view thereof; and
FIG. 7 is a left side elevational view thereof.

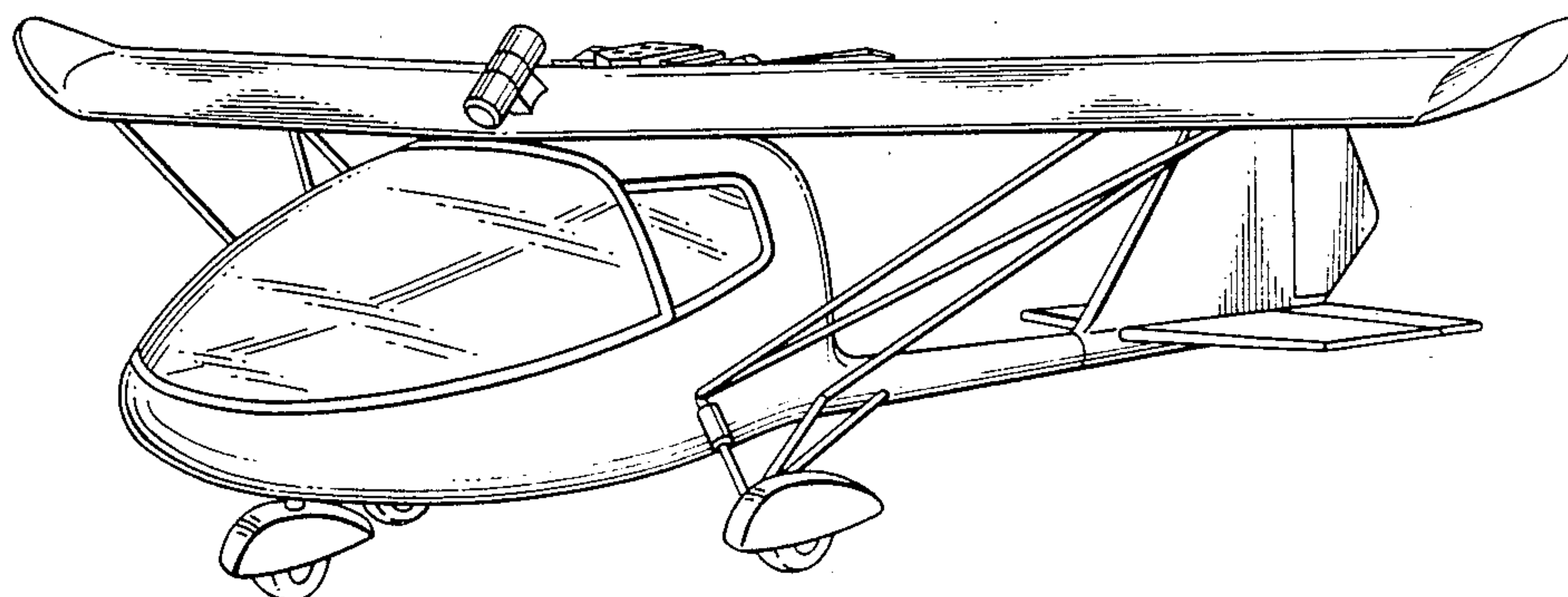

FIG. 1

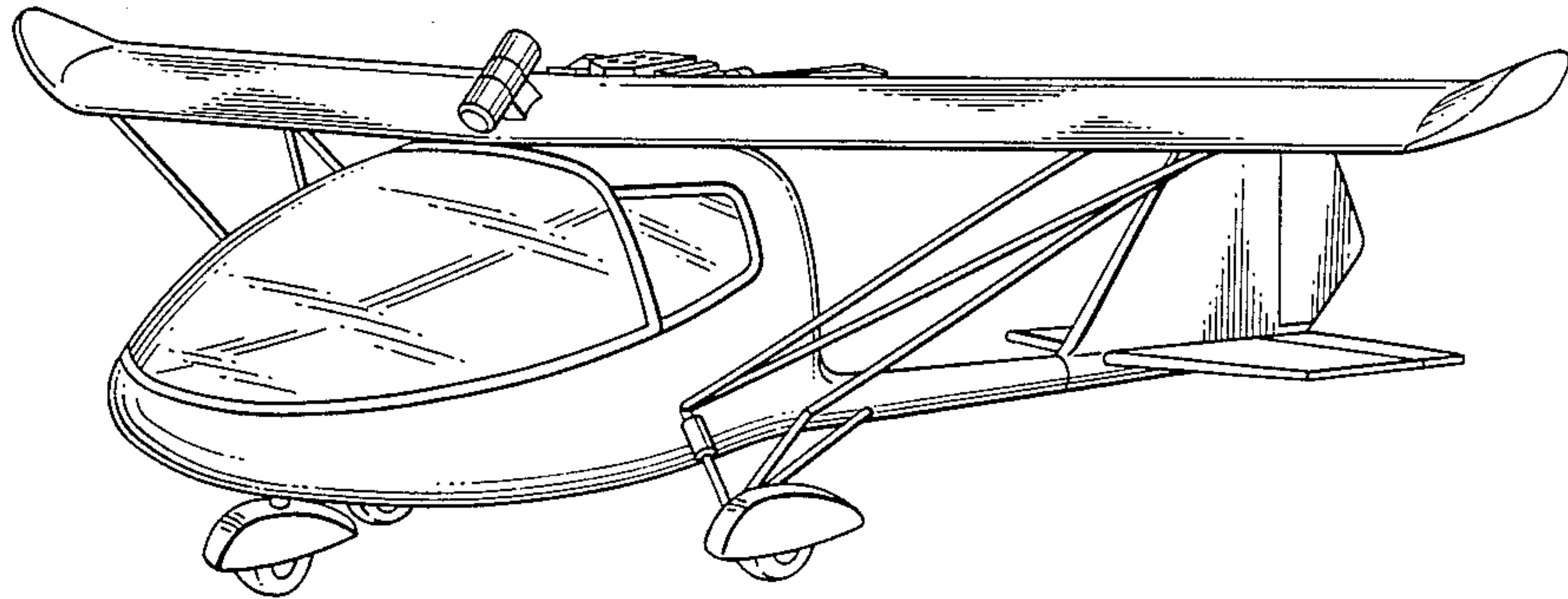

FIG. 2

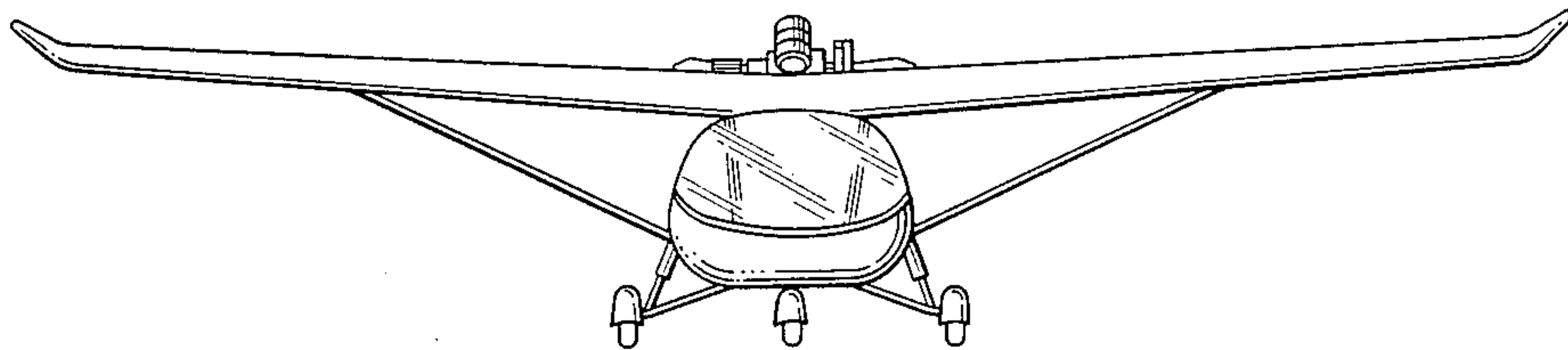

FIG. 3

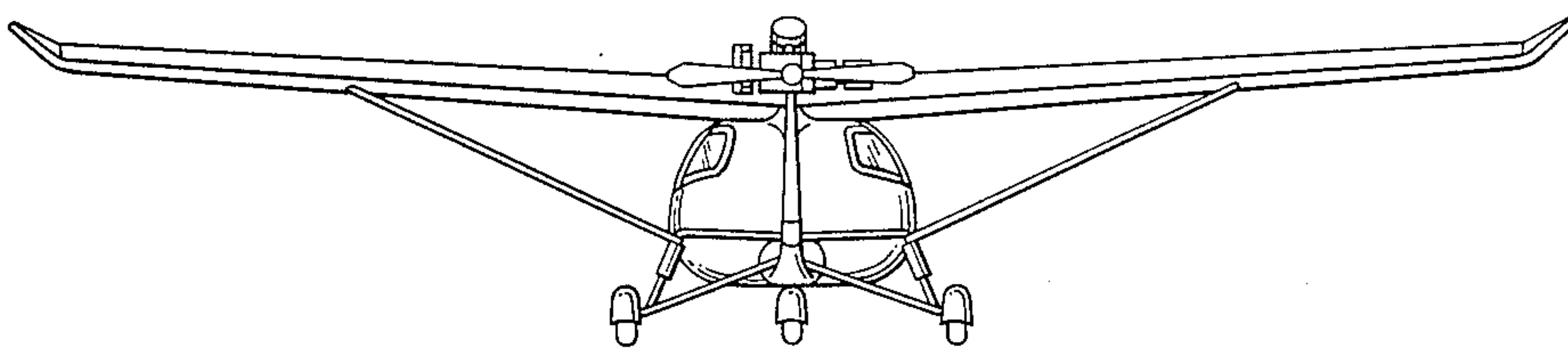

FIG. 4

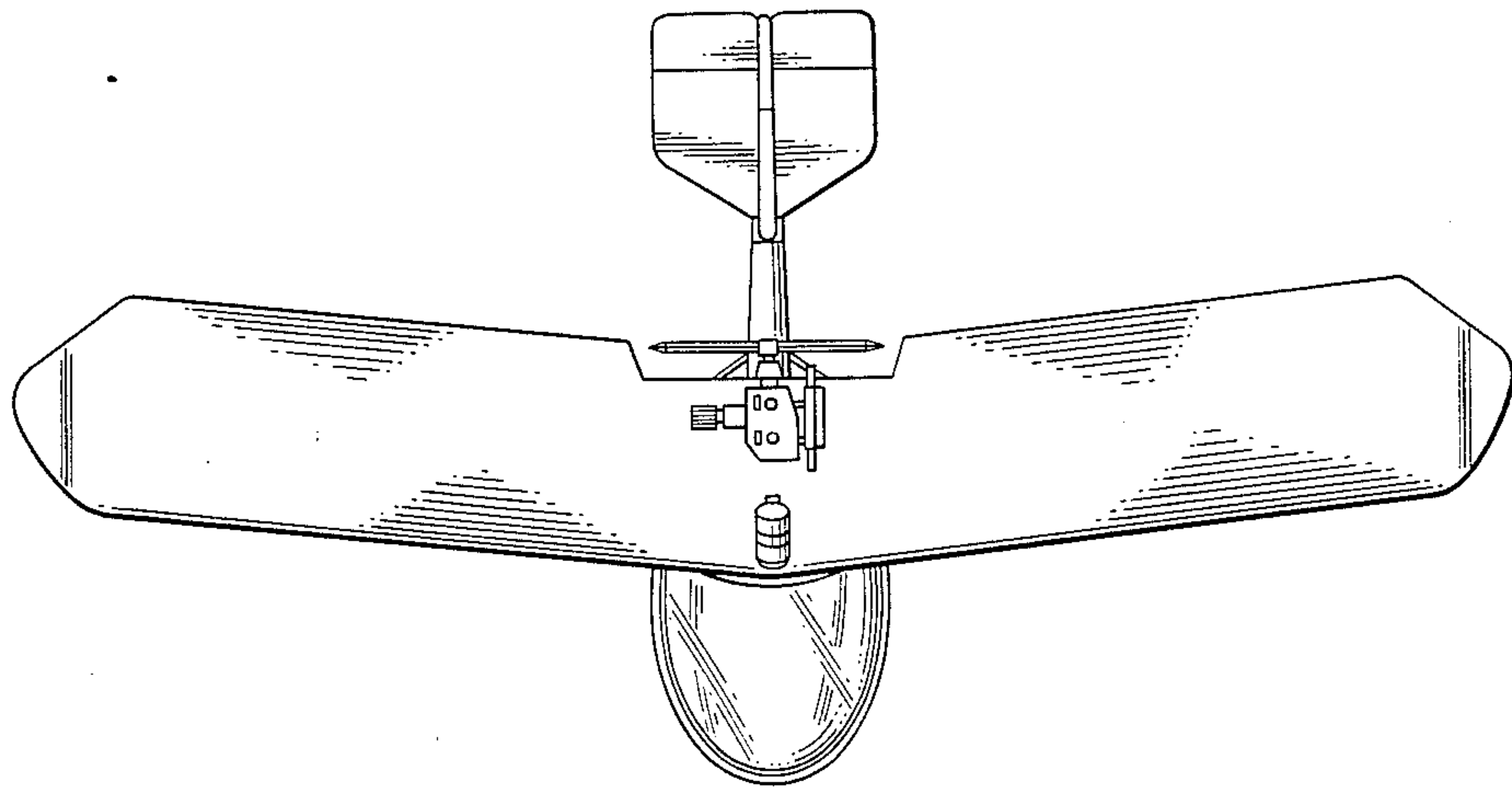

FIG. 5

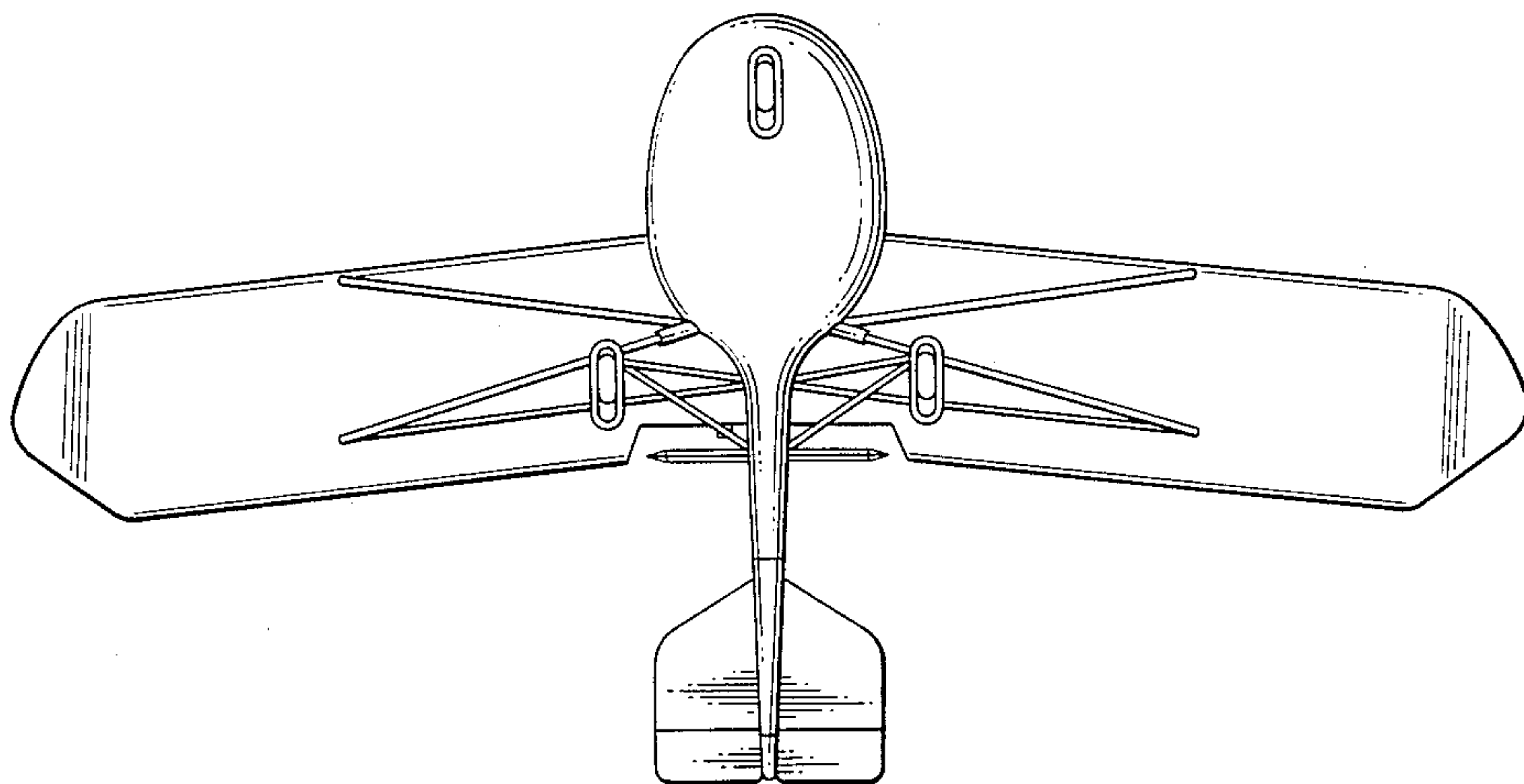

FIG. 6

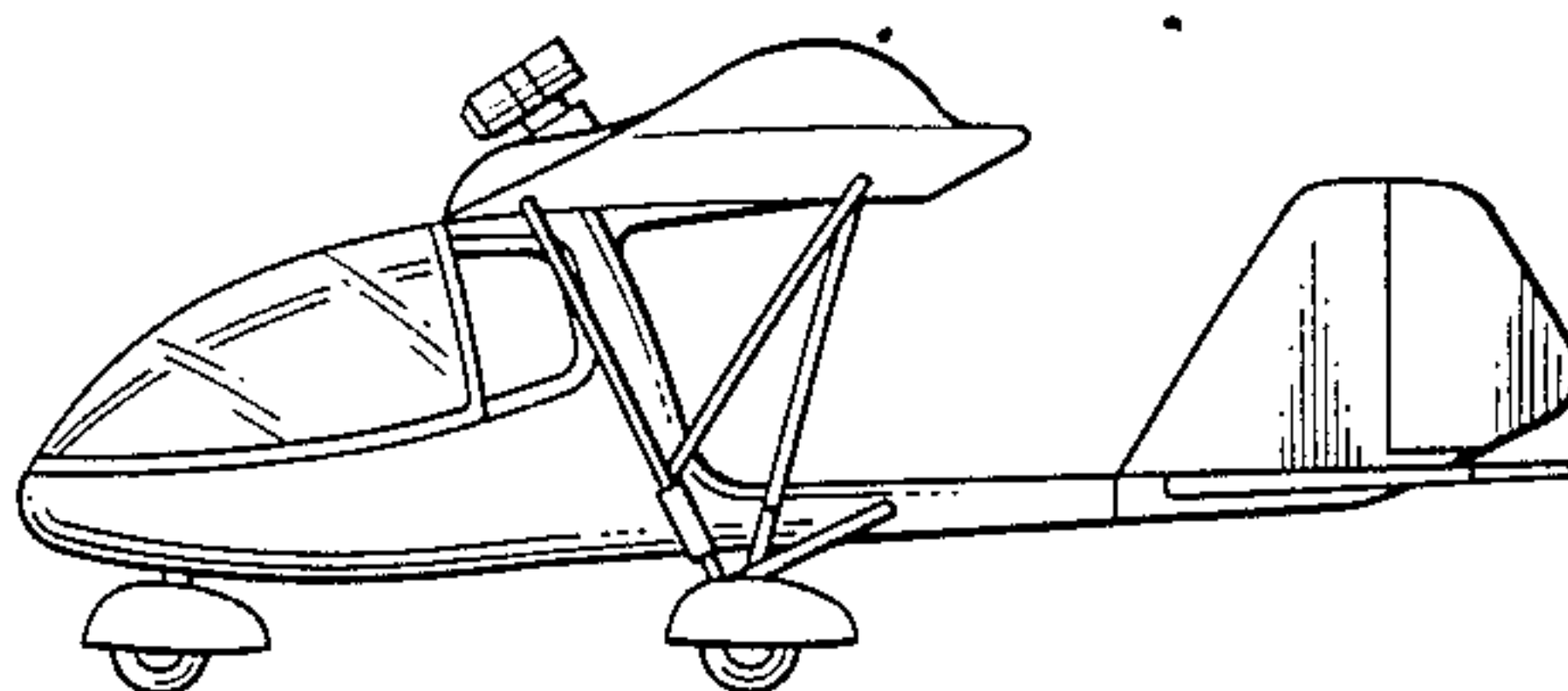

FIG. 7

