

[54] **TOW TRACTOR**

[75] **Inventor: Jay J. Reinhart, Battle Creek, Mich.**

[73] **Assignee: Clark Equipment Company, South Bend, Ind.**

[**] **Term: 14 Years**

[21] **Appl. No.: 144,391**

[22] **Filed: Jan. 15, 1988**

[52] **U.S. Cl. D12/14**

[58] **Field of Search D12/14, 1, 107, 3;
D15/15; 296/186, 1.1; 180/233, 54**

[56] **References Cited**

U.S. PATENT DOCUMENTS

D. 227,244	6/1973	Keene	D12/1
D. 282,153	1/1986	Wallace et al.	D12/14
D. 299,324	1/1989	Oba et al.	D12/3
3,064,746	11/1962	Williamson	180/54

OTHER PUBLICATIONS

New Equipment Digest, Jan. 1970, p. 65, Cushman Four-Wheel, Two Man Haulster Tractor. Clark CT Series brochure, copyright 1979.

Primary Examiner—James M. Gandy
Assistant Examiner—Melody Brown
Attorney, Agent, or Firm—King & Schickli

[57] **CLAIM**

The ornamental design for a tow tractor, as shown.

DESCRIPTION

FIG. 1 is a perspective view over the right rear quarter of the tow tractor, showing my new design;
FIG. 2 is a front perspective view thereof over the right front quarter;
FIG. 3 is a front elevational view thereof;
FIG. 4 is a rear elevational view thereof;
FIG. 5 is a left side elevational view thereof;
FIG. 6 is a right side elevational view thereof;
FIG. 7 is a top plan view thereof.

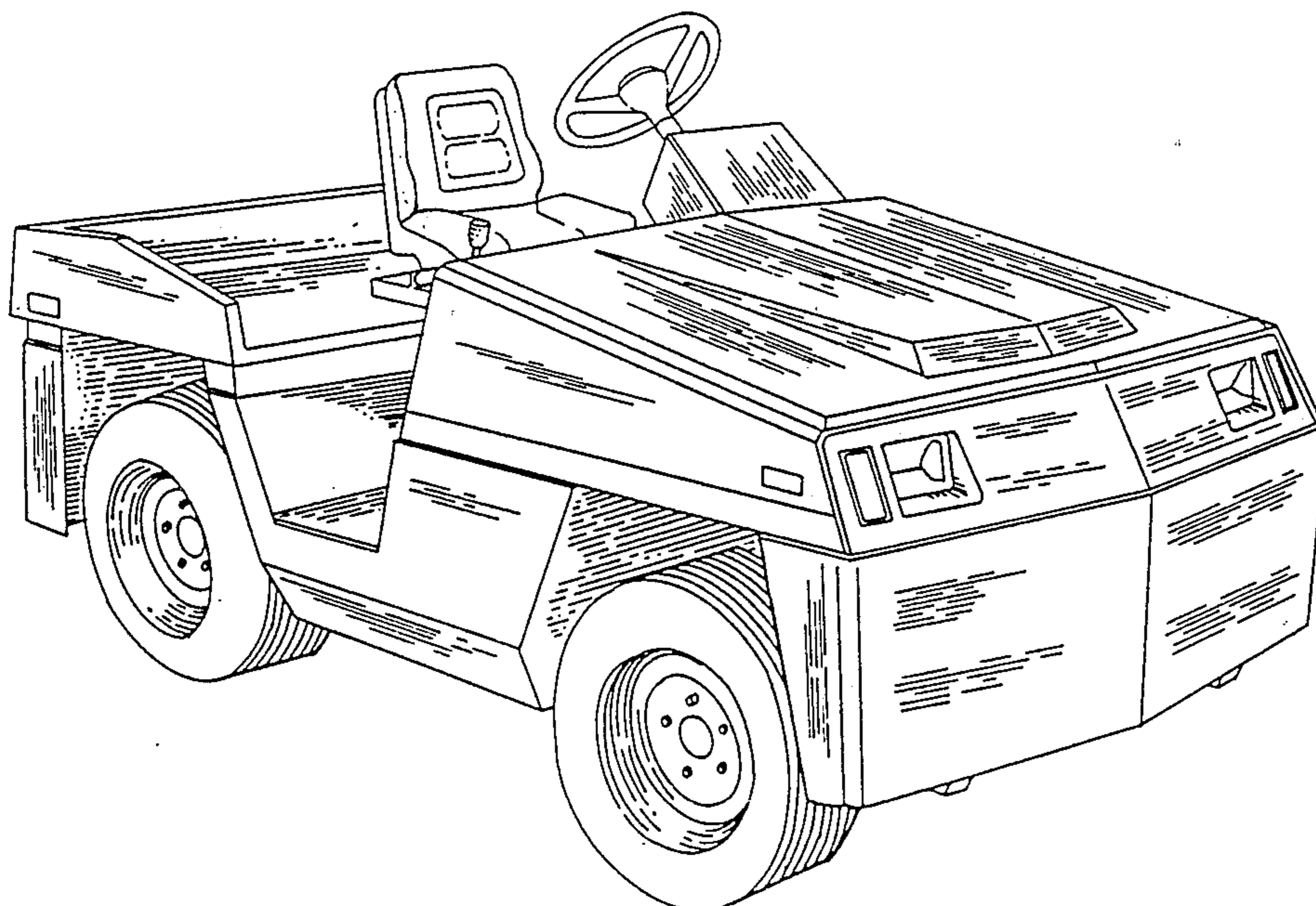

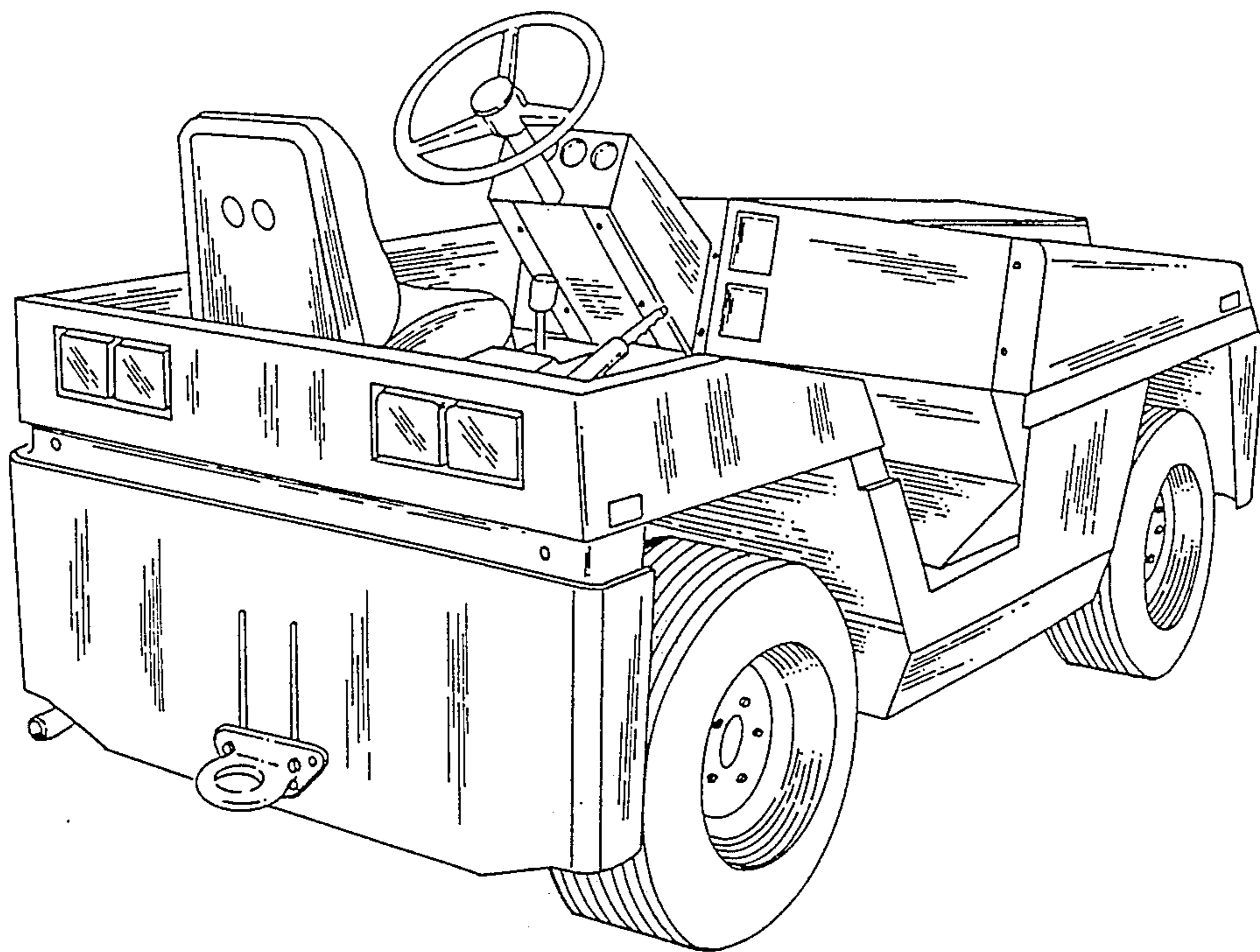

FIG. 1

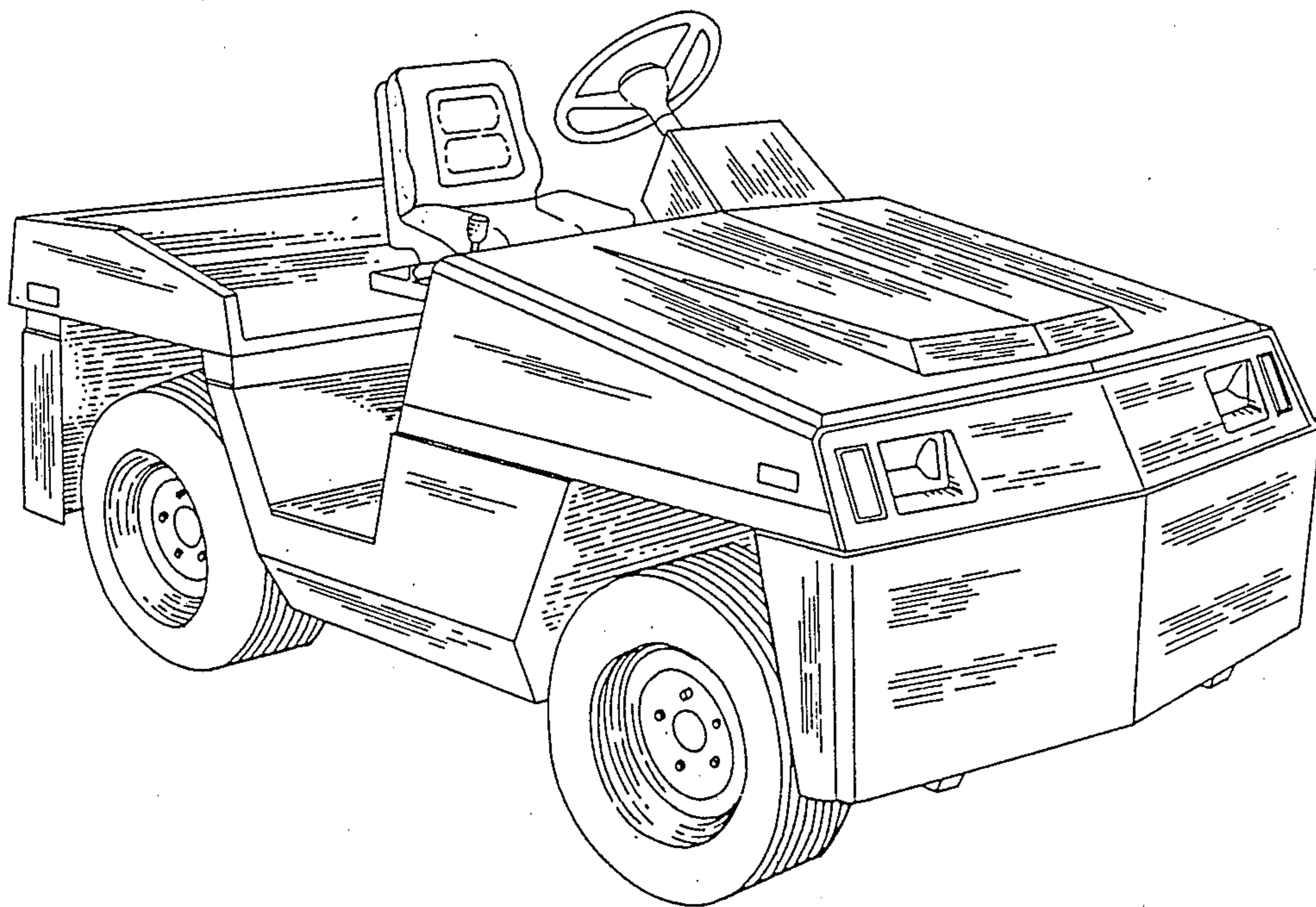

FIG. 2

FIG. 3

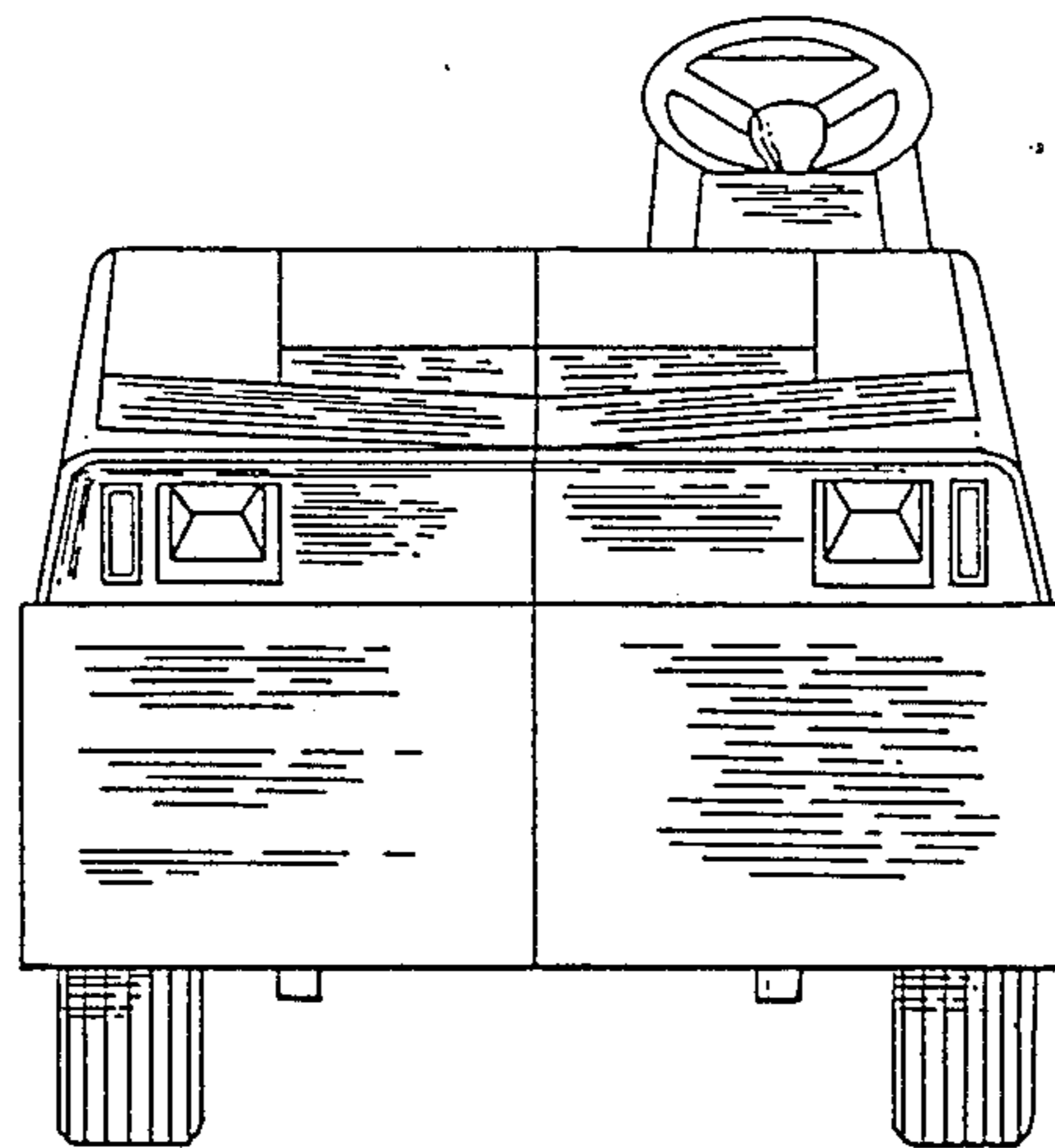

FIG. 4

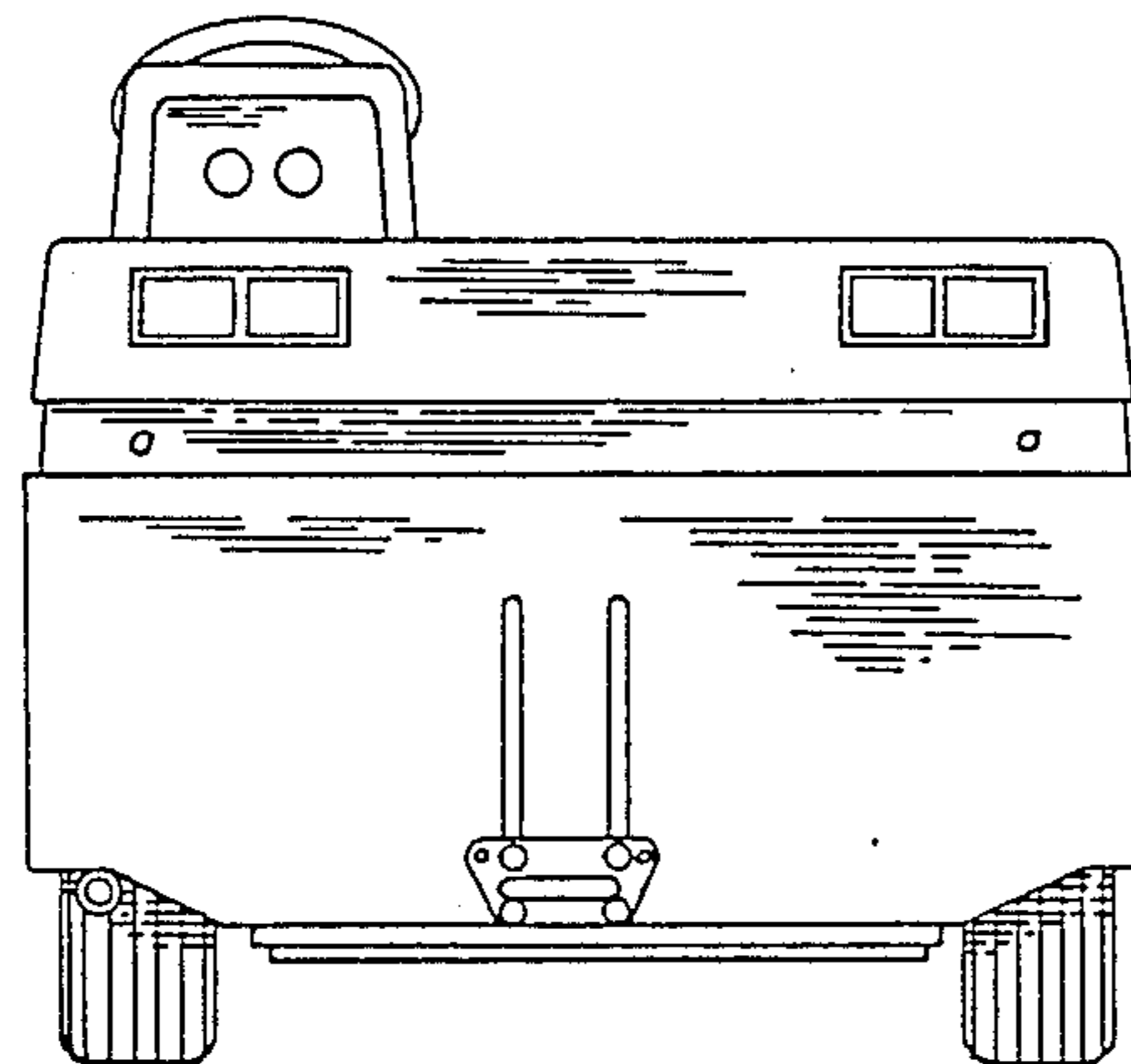

FIG. 5

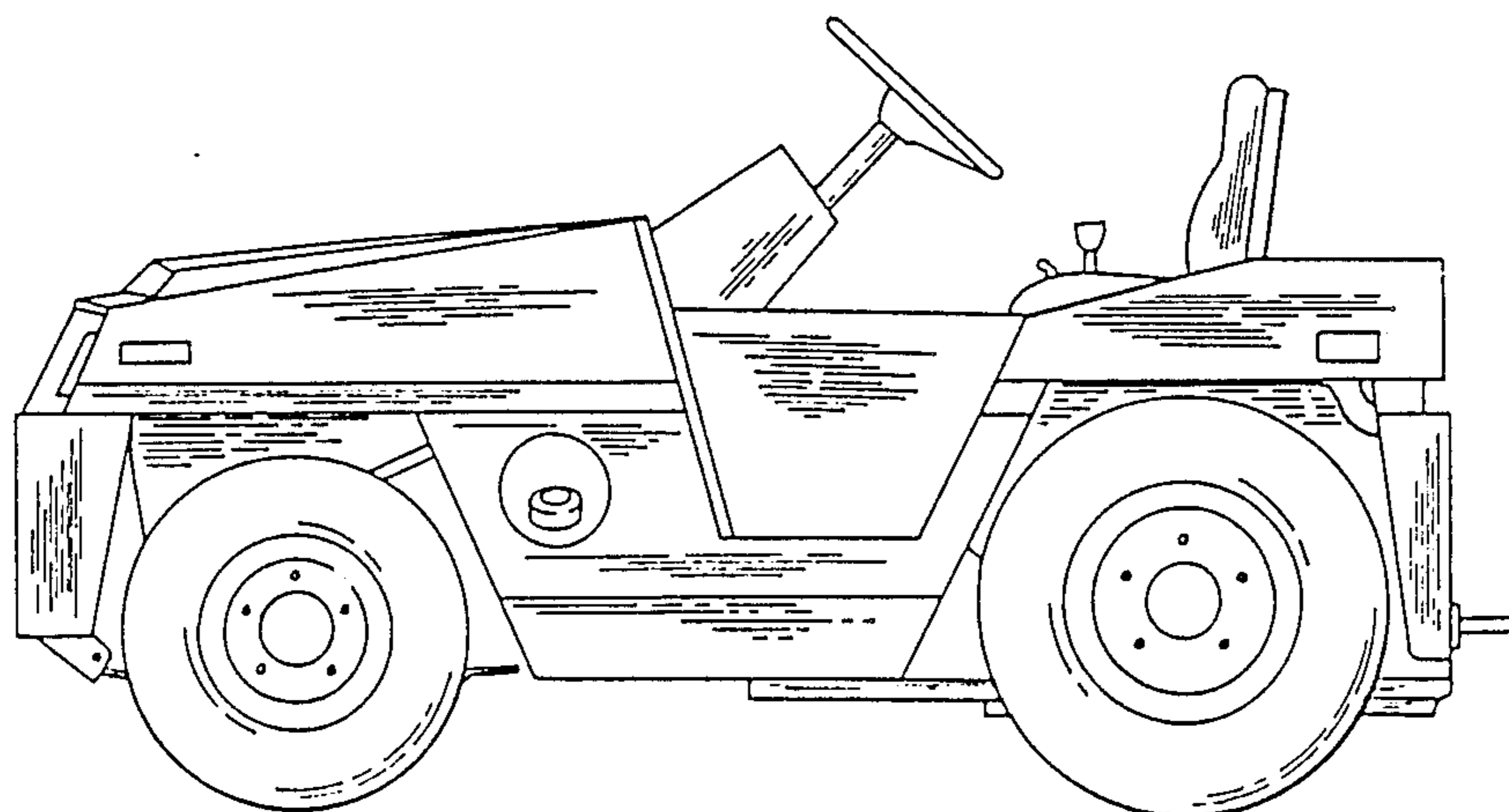

FIG. 6

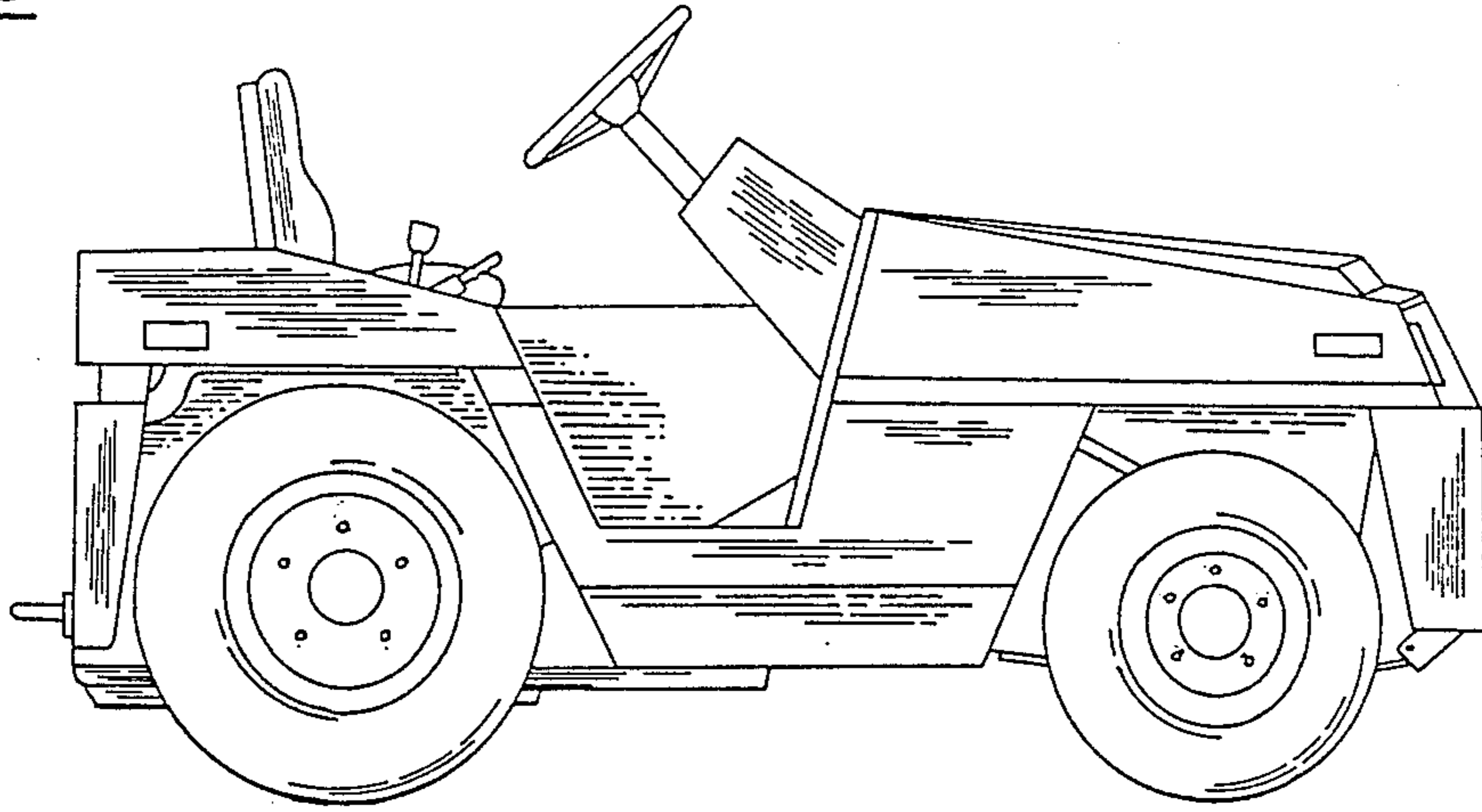

FIG. 7

