

[54] **MERCHANDISING DISPLAY STAND OR THE LIKE**

[75] **Inventor:** William Prendergast, Park Ridge, N.J.

[73] **Assignee:** Philip Morris Incorporated, New York, N.Y.

[*] **Notice:** The portion of the term of this patent subsequent to Oct. 23, 2004 has been disclaimed.

[**] **Term:** 14 Years

[21] **Appl. No.:** 938,774

[22] **Filed:** Dec. 5, 1986

[52] **U.S. Cl.** D6/461; D6/455

[58] **Field of Search** D6/455, 456, 457, 458, D6/459, 460, 461; 211/13, 42

[56] **References Cited**

U.S. PATENT DOCUMENTS

D. 241,998 10/1976 Rohrer et al. D6/461 X
2,972,415 2/1961 Rensch D6/461 X

Primary Examiner—Bruce W. Dunkins
Assistant Examiner—Jeffrey Asch
Attorney, Agent, or Firm—Charles B. Smith

[57] **CLAIM**

The ornamental design for a merchandising display stand or the like, as shown and described.

DESCRIPTION

FIG. 1 is a perspective view of a merchandising display stand or the like showing my new design;
FIG. 2 is a front elevational view, top plan view thereof; and
FIG. 3 is a bottom plan view thereof.

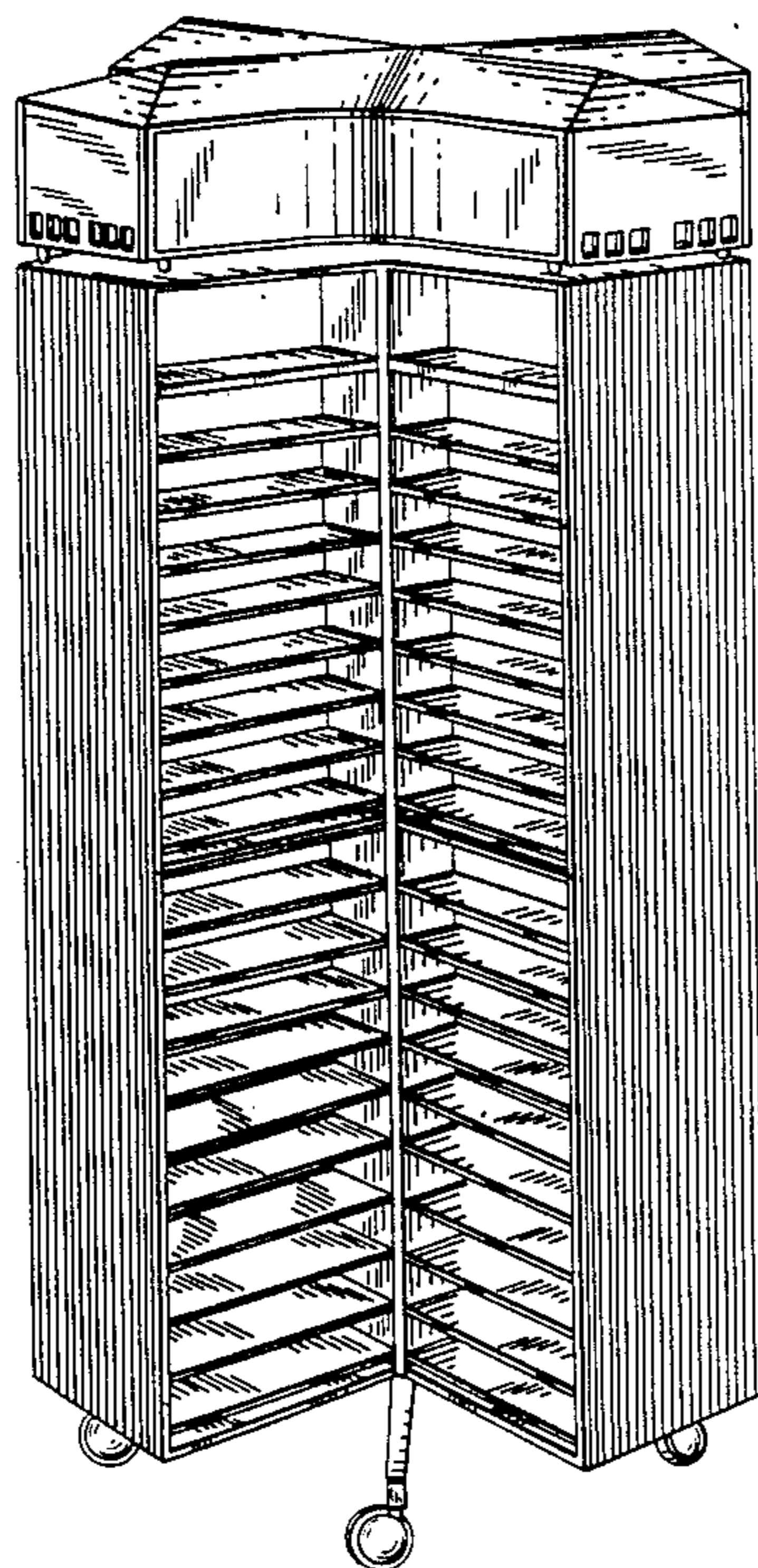

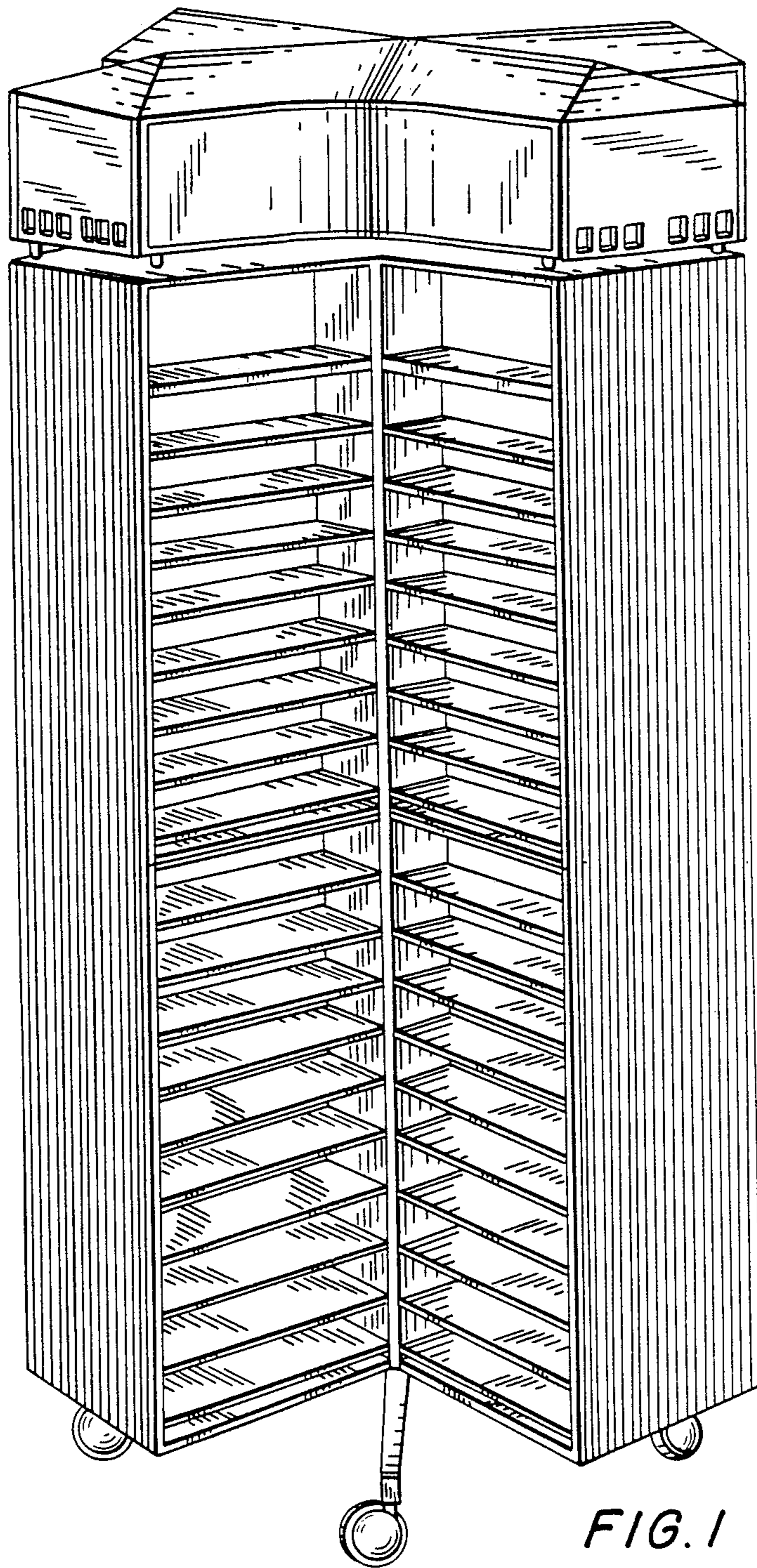

FIG. 1

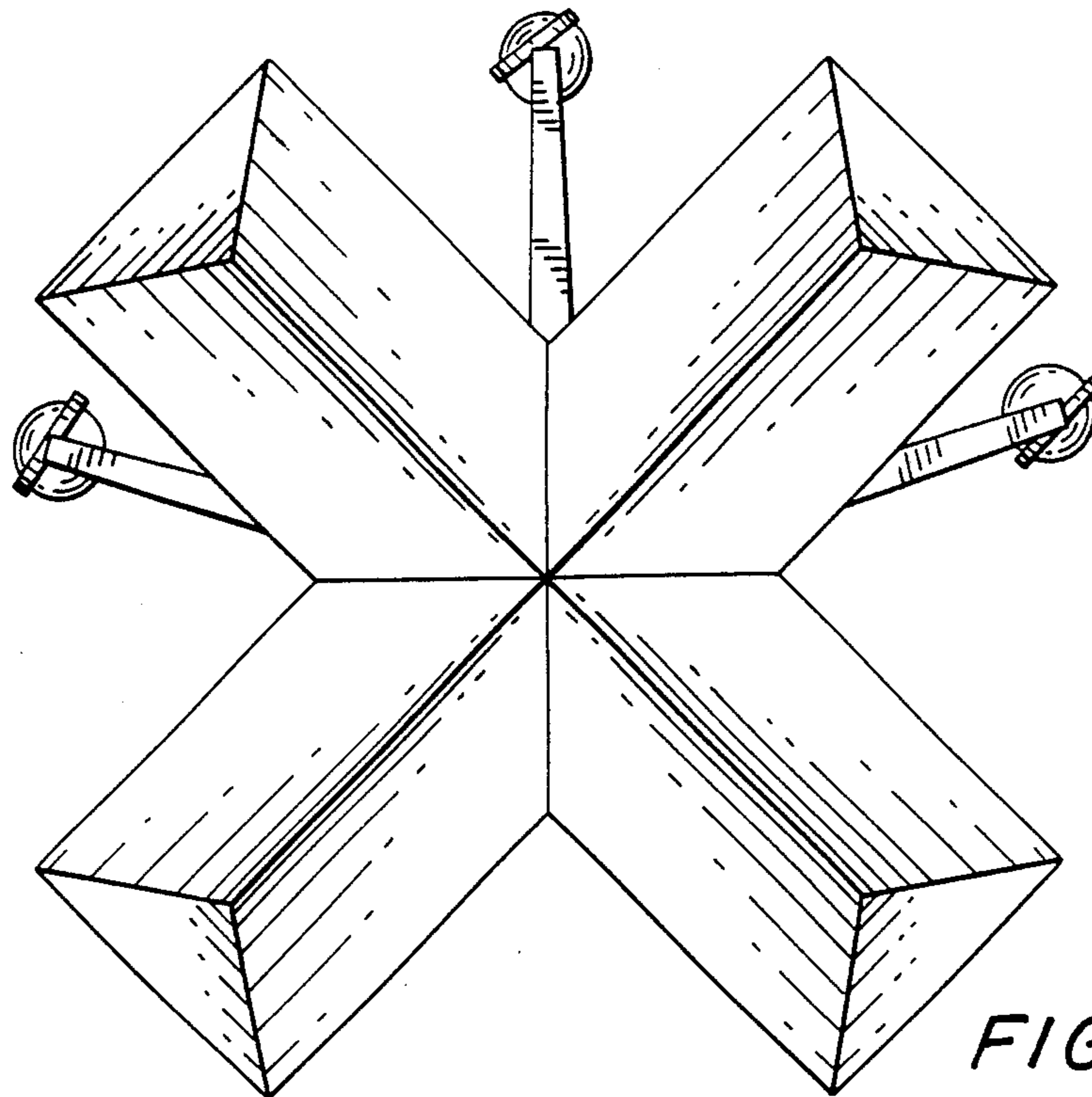

FIG. 2

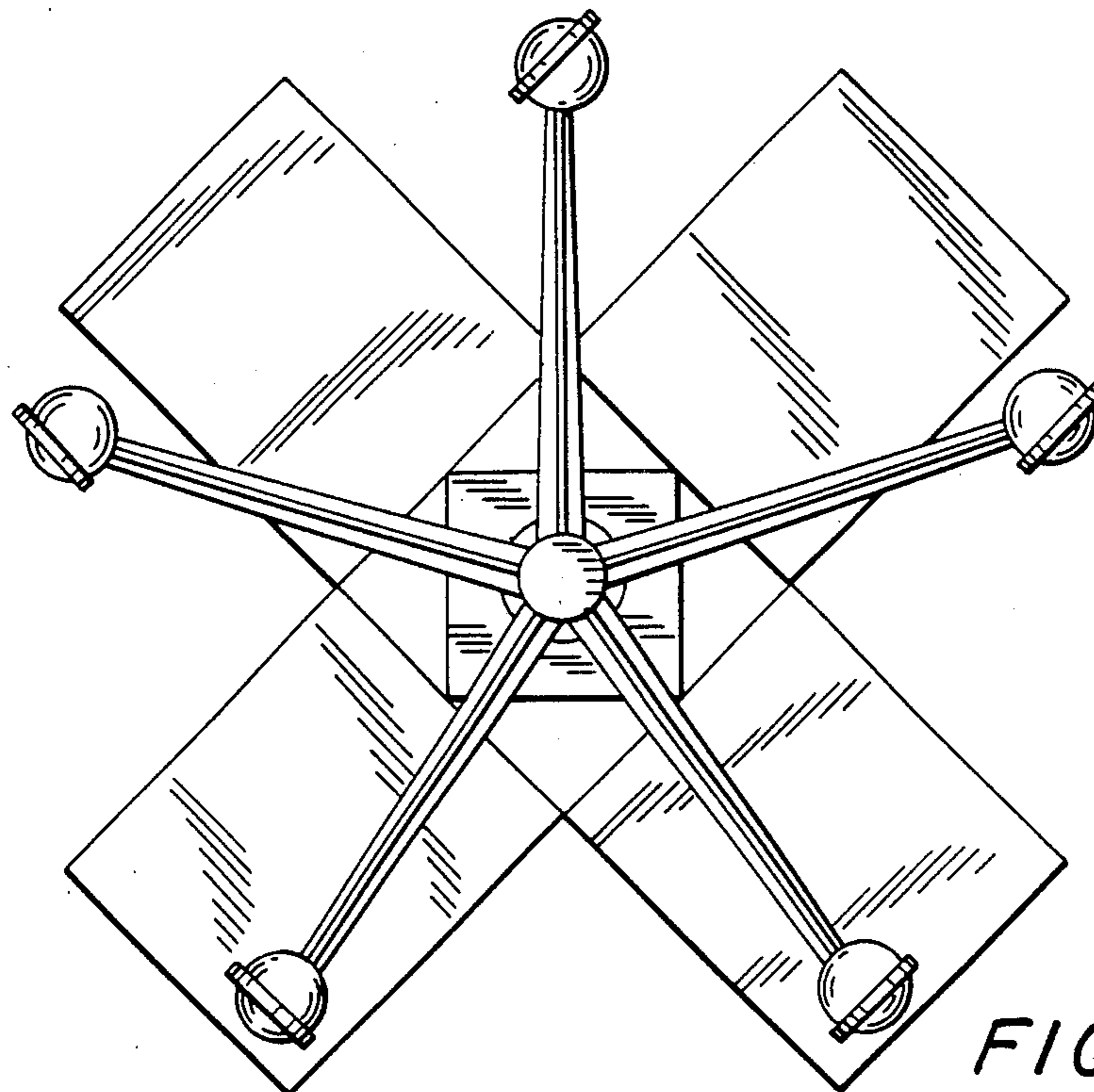

FIG. 3