

[54] COMBINED TOY SAND BOX AND LID

3,691,672 9/1972 Pendill 446/70

[75] Inventor: Donald F. Cattoni, Warwick, R.I.

Primary Examiner—Charles A. Rademaker

Assistant Examiner—Alicia A. Farrell

[73] Assignee: Spang & Company, Butler, Pa.

Attorney, Agent, or Firm—Raymond N. Baker

[**] Term: 14 Years

[57] CLAIM

[21] Appl. No.: 144,868

The ornamental design for a combined toy sand box and lid, as shown and described.

[22] Filed: Jan. 15, 1988

DESCRIPTION

[52] U.S. Cl. D21/252

[58] Field of Search D21/252; 272/1 A; 446/153, 70

FIG. 1 is a perspective view of a combined toy sand box and lid showing my new design;

FIG. 2 is a perspective view thereof with the lid removed;

FIG. 3 is a front elevational view thereof;

FIG. 4 is a top plan view thereof;

FIG. 5 is a side elevational view thereof with the lid in a raised position, all sides being substantially identical; and

FIG. 6 is a top plan view thereof with the lid removed.

[56] References Cited

U.S. PATENT DOCUMENTS

- D. 213,839 4/1969 Diamond D21/252
- D. 245,524 8/1977 Friedlander D21/252
- D. 280,436 9/1985 Mariol D21/252
- 3,020,045 7/1959 Moss D21/252

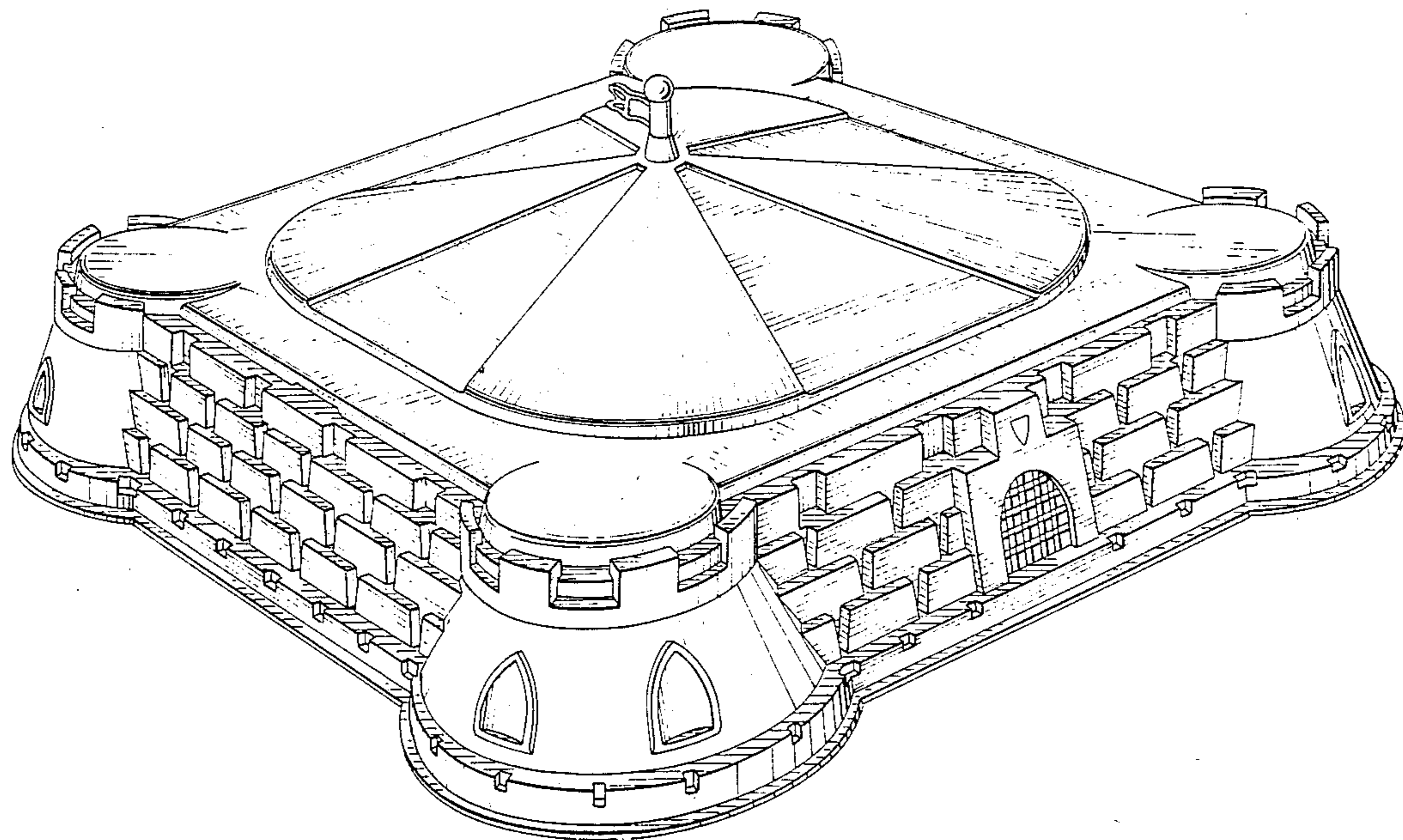

FIG. 1

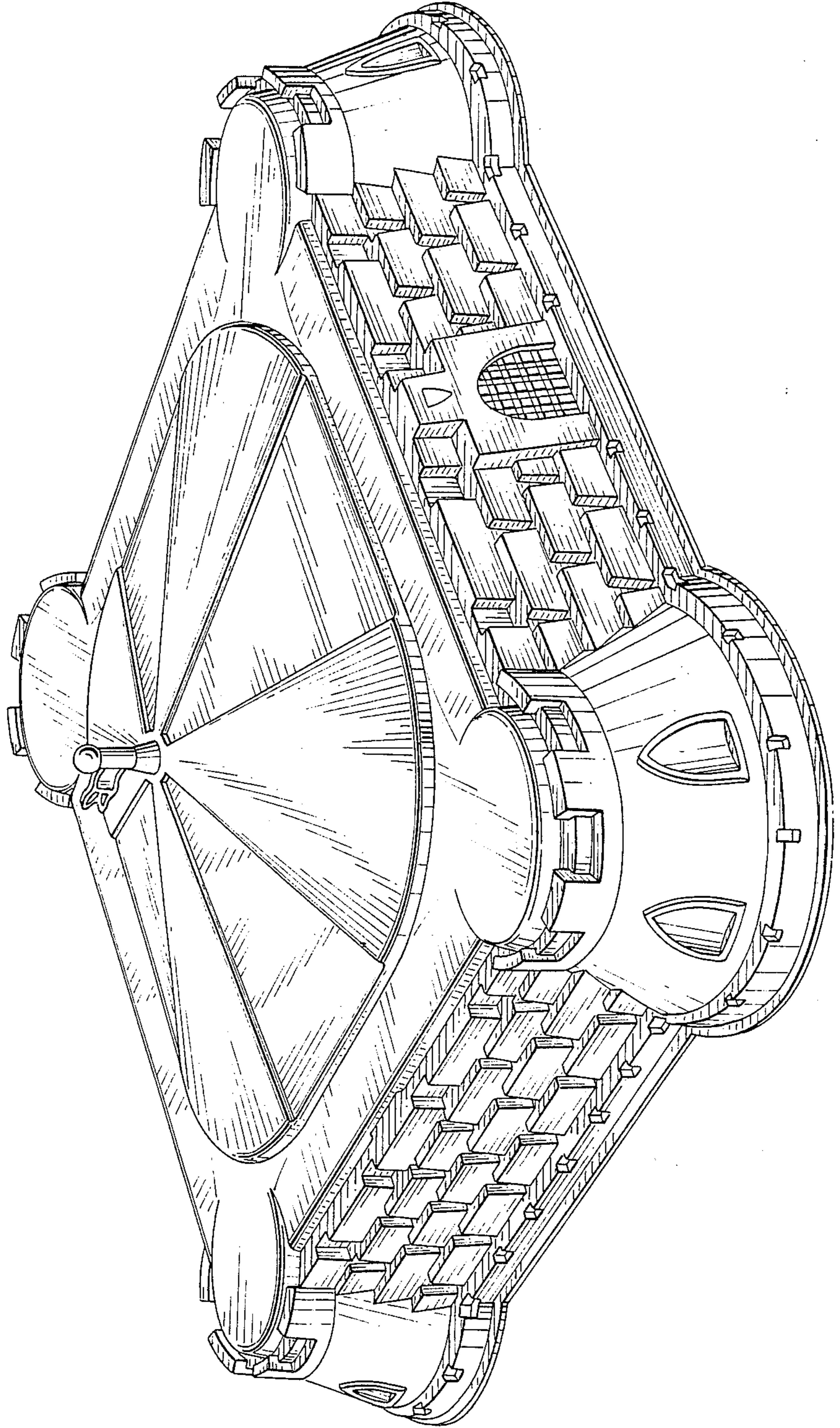

FIG. 2

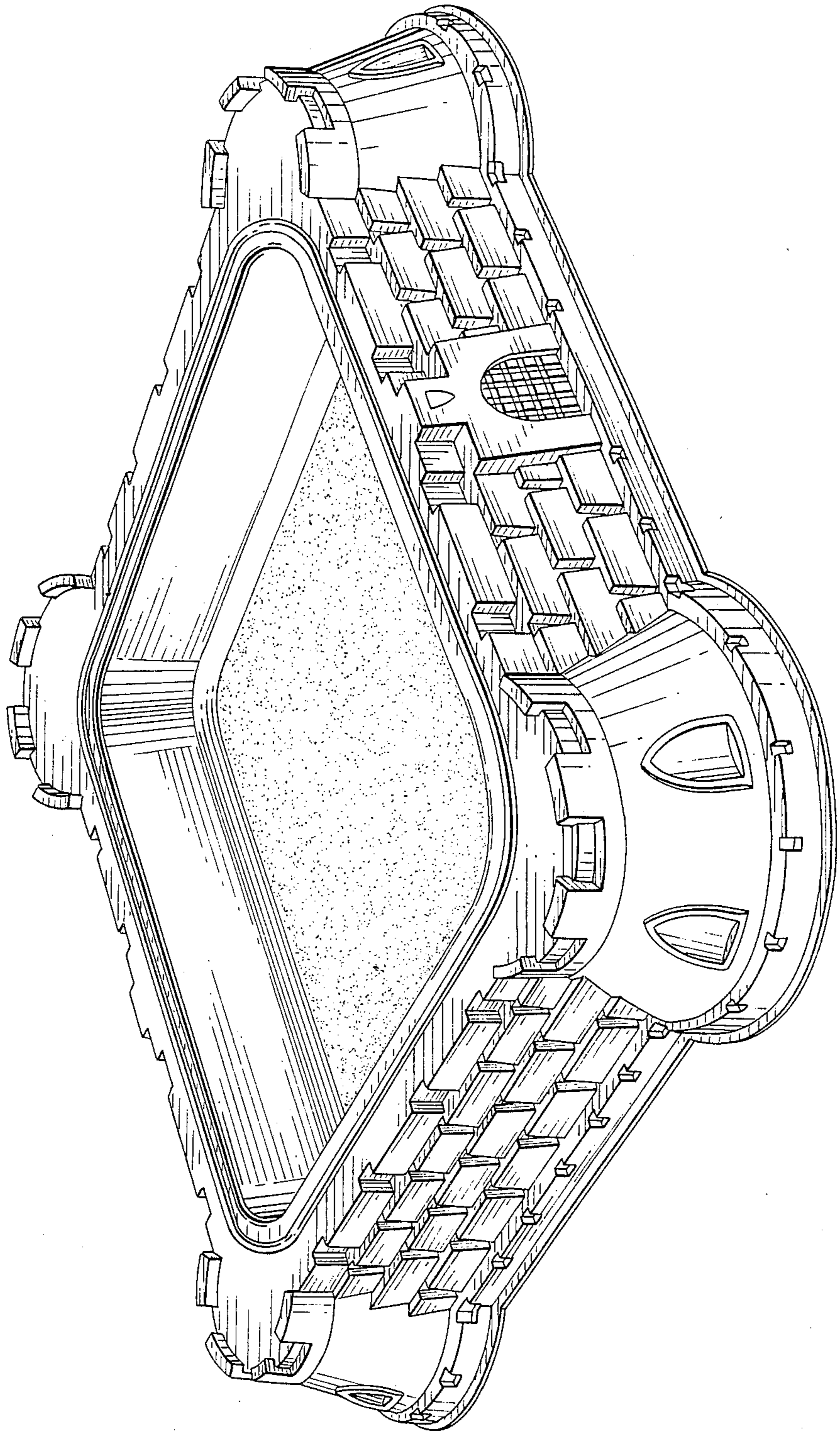

FIG. 3

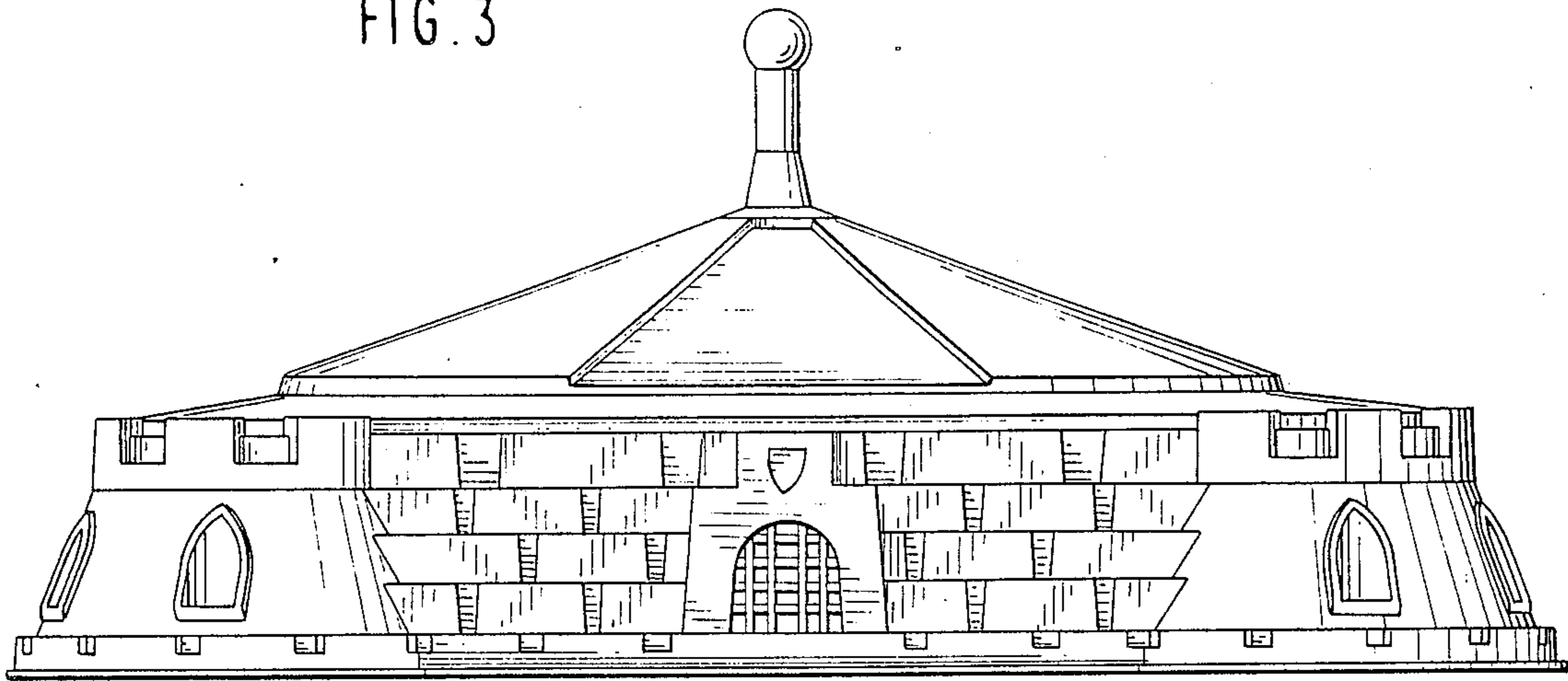

FIG. 4

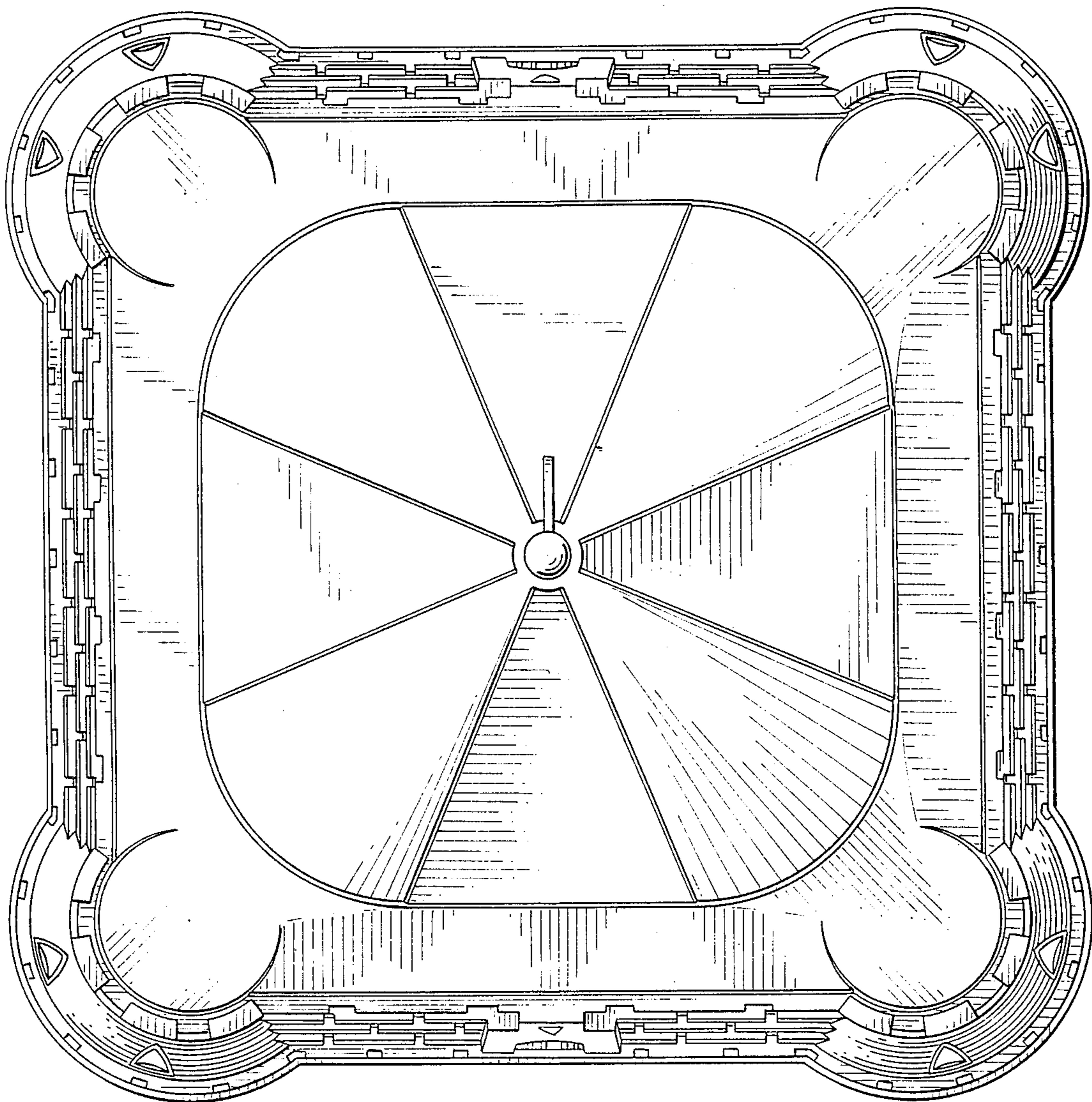

FIG. 5

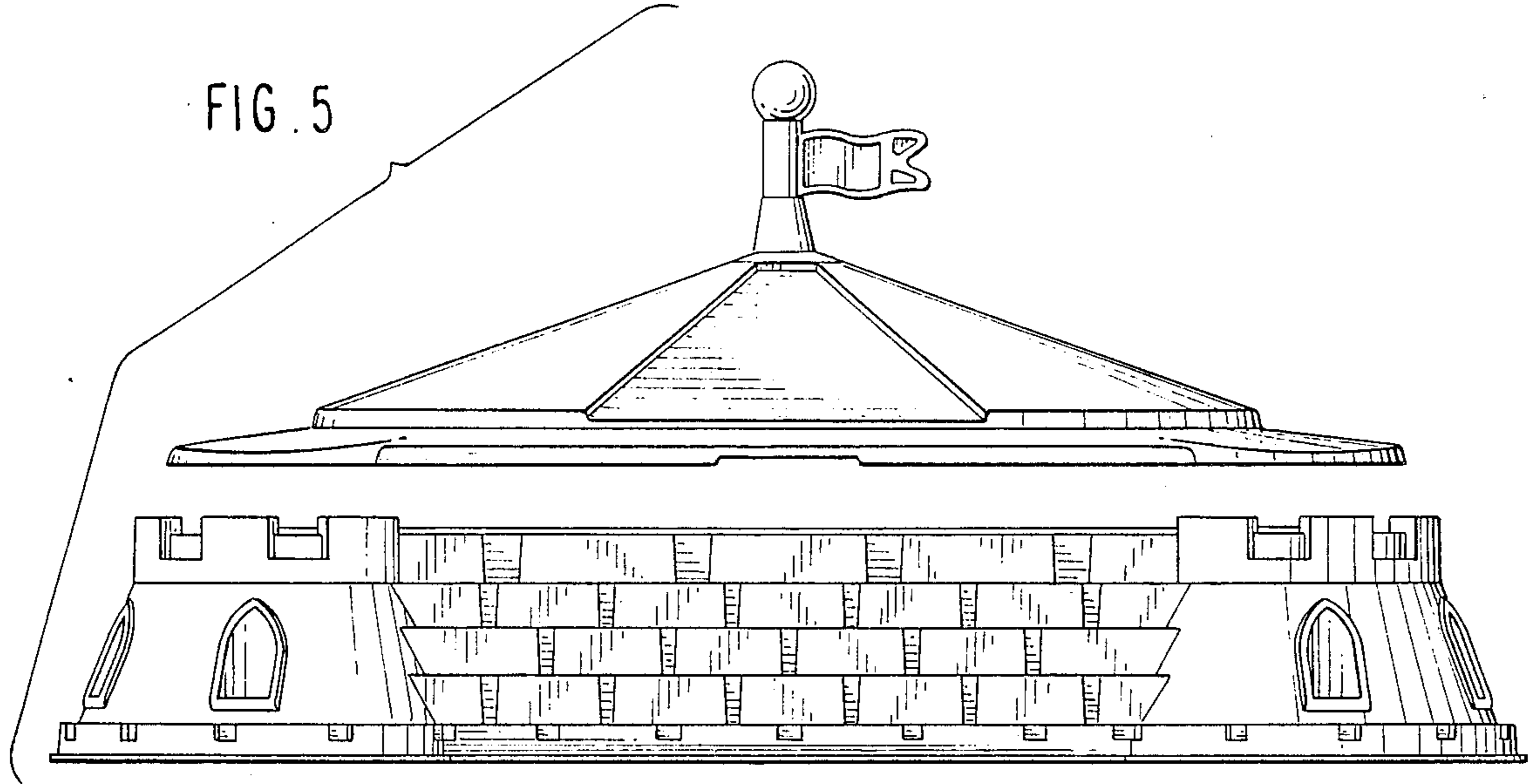

FIG. 6

