

[54] TUNING MACHINE FOR GUITAR

[75] Inventors: Daniel J. Smith; Charles H. Todd, III, both of La Habra, Calif.

[73] Assignee: Fender Musical Instruments Corporation, Brea, Calif.

[\*\*] Term: 14 Years

[21] Appl. No.: 492,216

[22] Filed: May 6, 1983

[52] U.S. Cl. .... D17/20

[58] Field of Search ..... D17/14, 15, 18-20

[56] References Cited

U.S. PATENT DOCUMENTS

D. 249,583	9/1978	Worthing et al. ....	D17/20
D. 256,367	8/1980	Bolen .....	D17/14
D. 274,732	7/1984	Hampton et al. ....	D17/14
3,427,916	2/1969	Fender .....	84/267

OTHER PUBLICATIONS

U.S. Trademark Reg. No. 1,138,967, Registered 8-2-6-80, Music Man, Inc.

*American Guitars*, T. Wheeler, Harper & Row, N.Y., ©'82, p. 183, Gibson '63 EB-6 & '72 EB-3 Tuning Machines.

Page 5 of Fender Muscial Instruments (assignee herein) 1982 catalog.

*Primary Examiner*—Bernard Ansher

*Assistant Examiner*—Theodore M. Shooman

*Attorney, Agent, or Firm*—Richard L. Gausewitz

[57] CLAIM

The ornamental design for a tuning machine for guitar, as shown and described.

DESCRIPTION

FIG. 1 is a front elevational view of a tuning machine for a guitar showing our new design; FIG. 2 is a left side elevational view; FIG. 3 is a right side elevational view; FIG. 4 is a top plan view; FIG. 5 is a bottom plan view; and FIG. 6 is a rear elevational view.

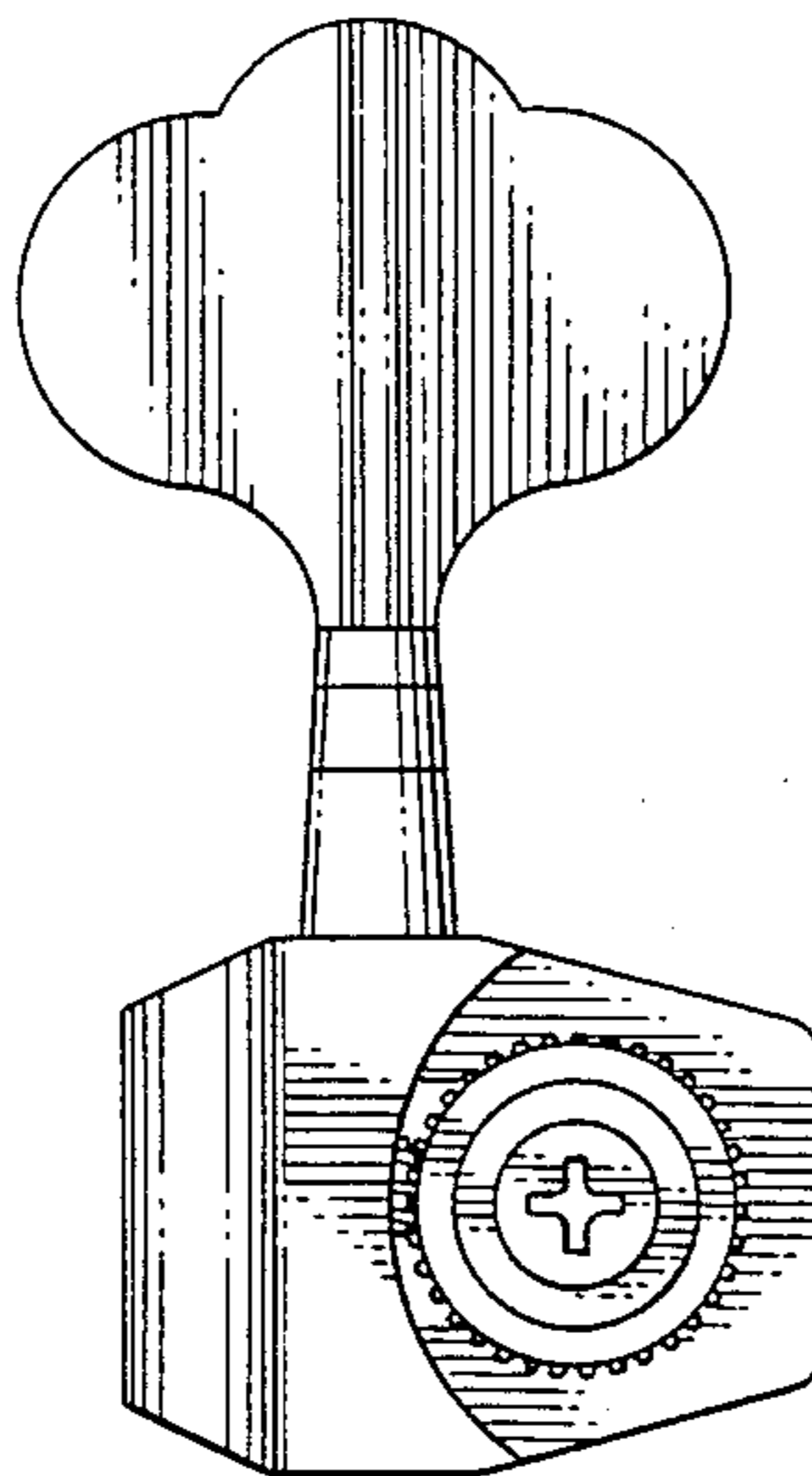

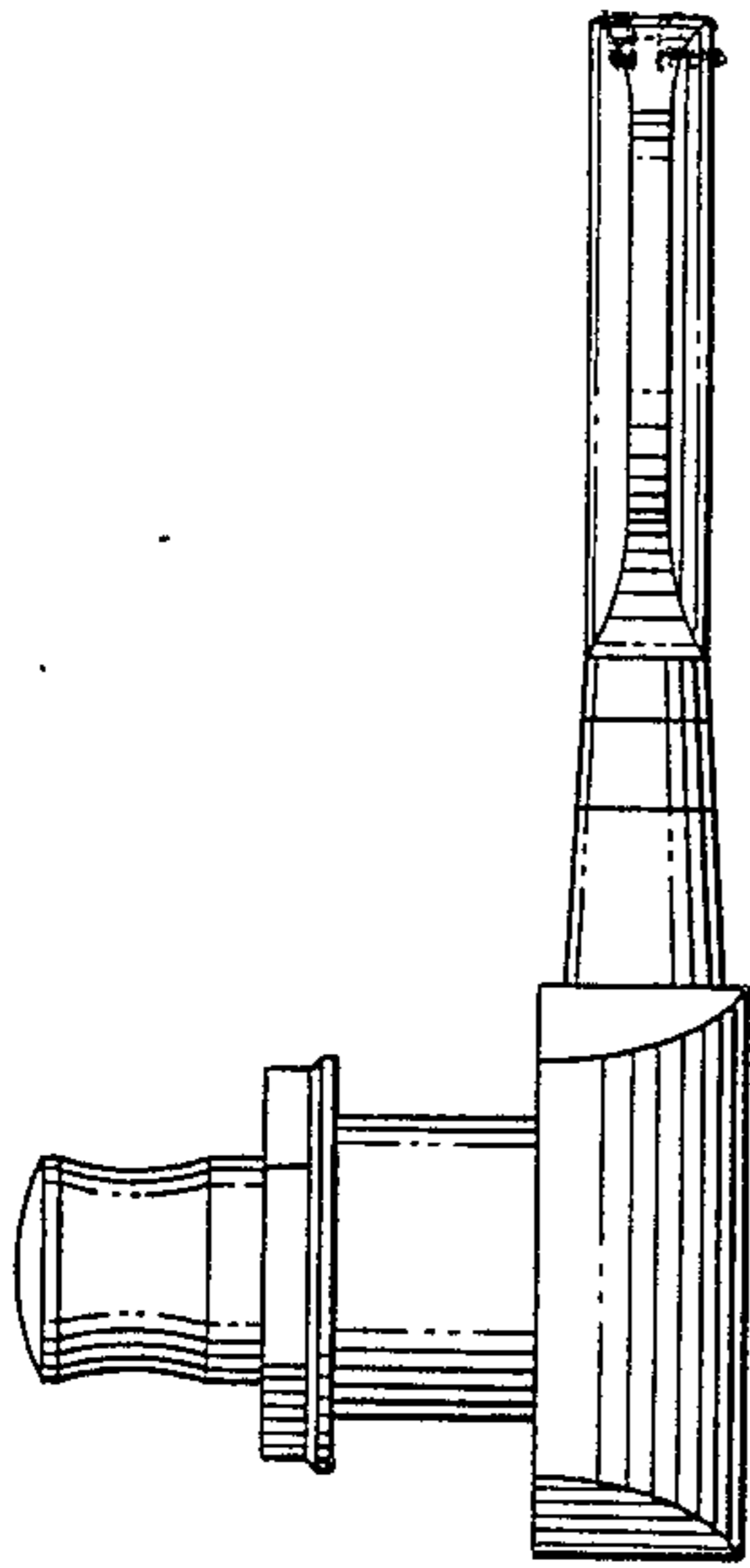

FIG. 2.

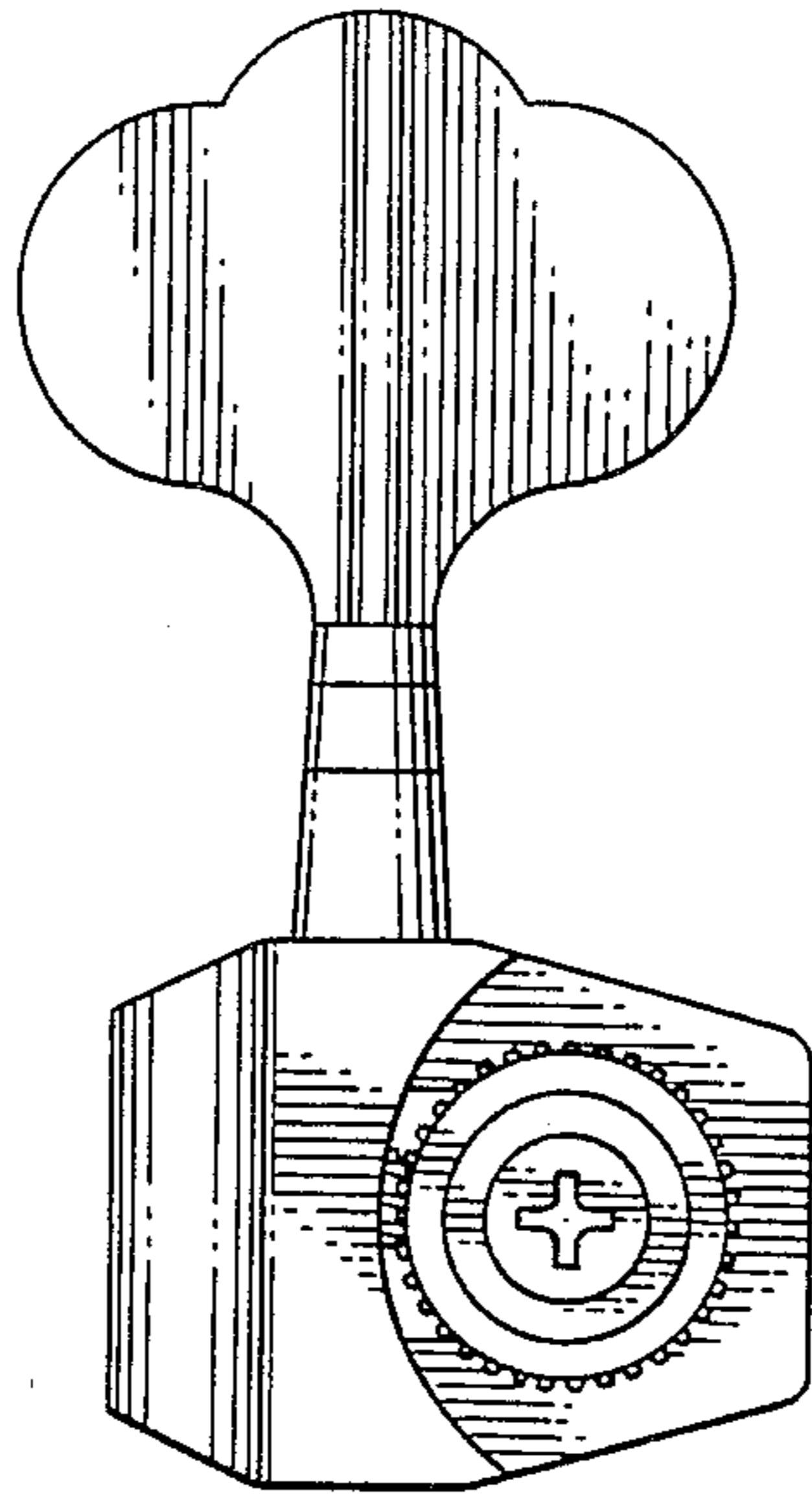

FIG. 1.

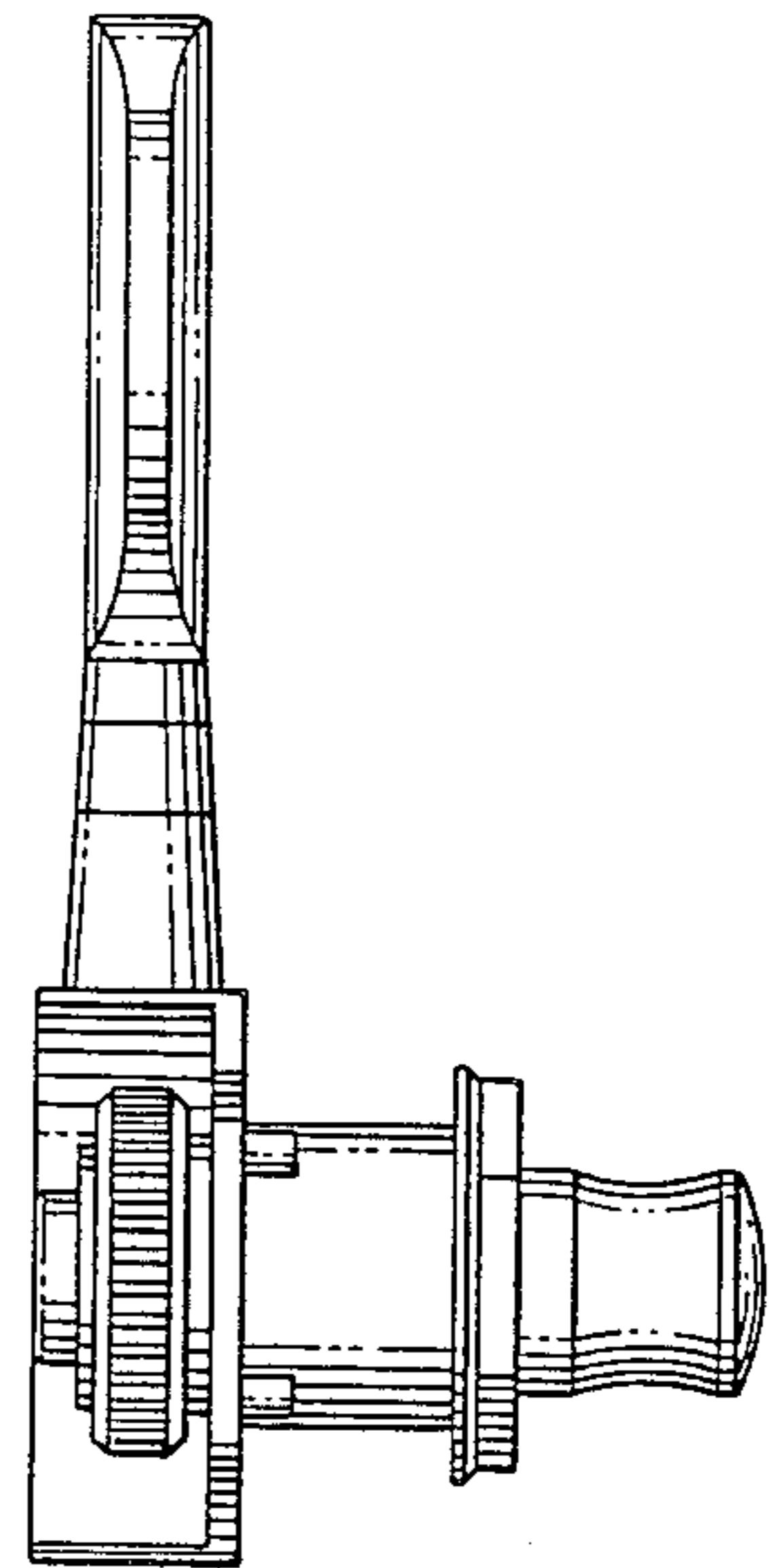

FIG. 3.

FIG. 4.

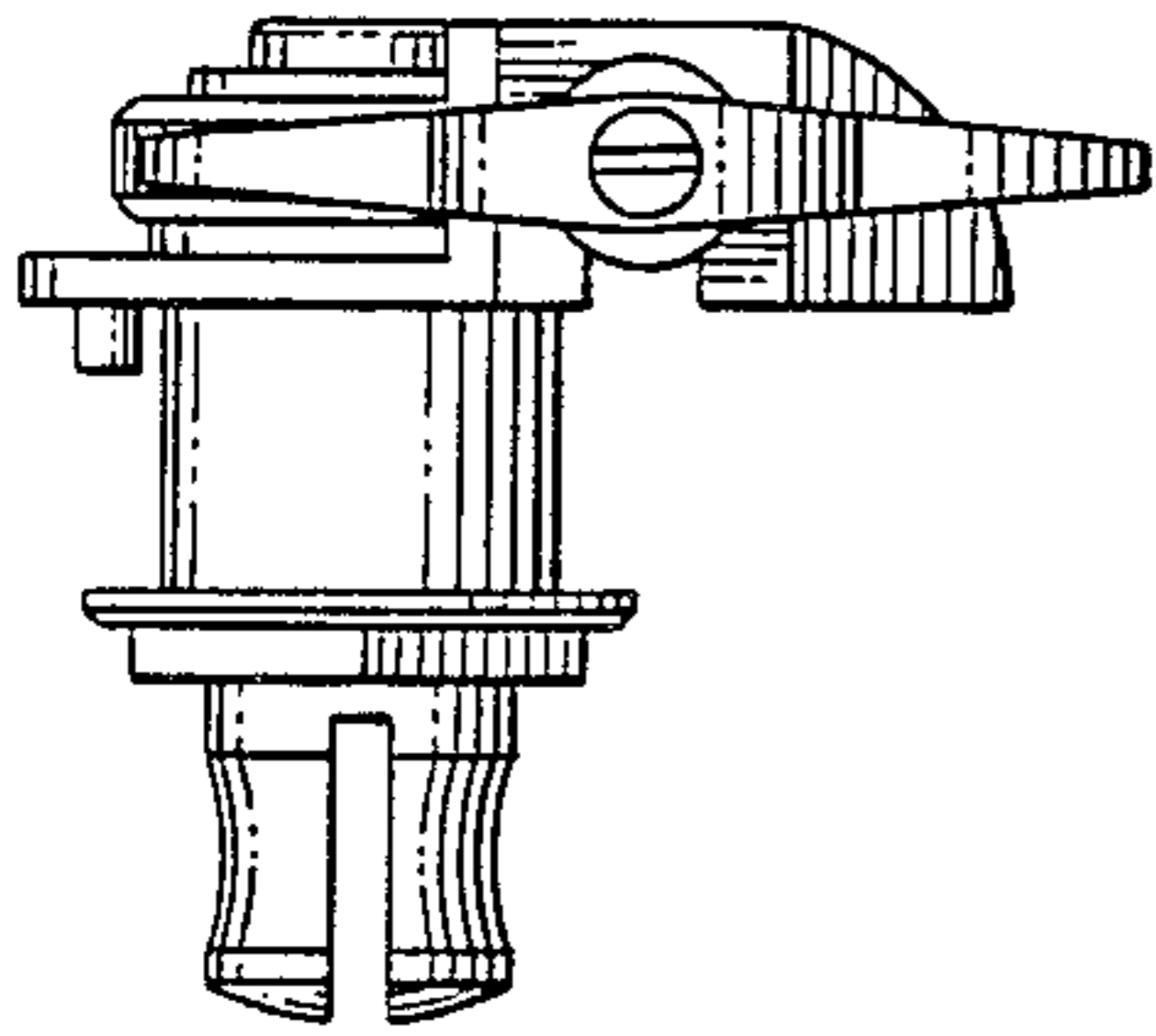

FIG. 5.

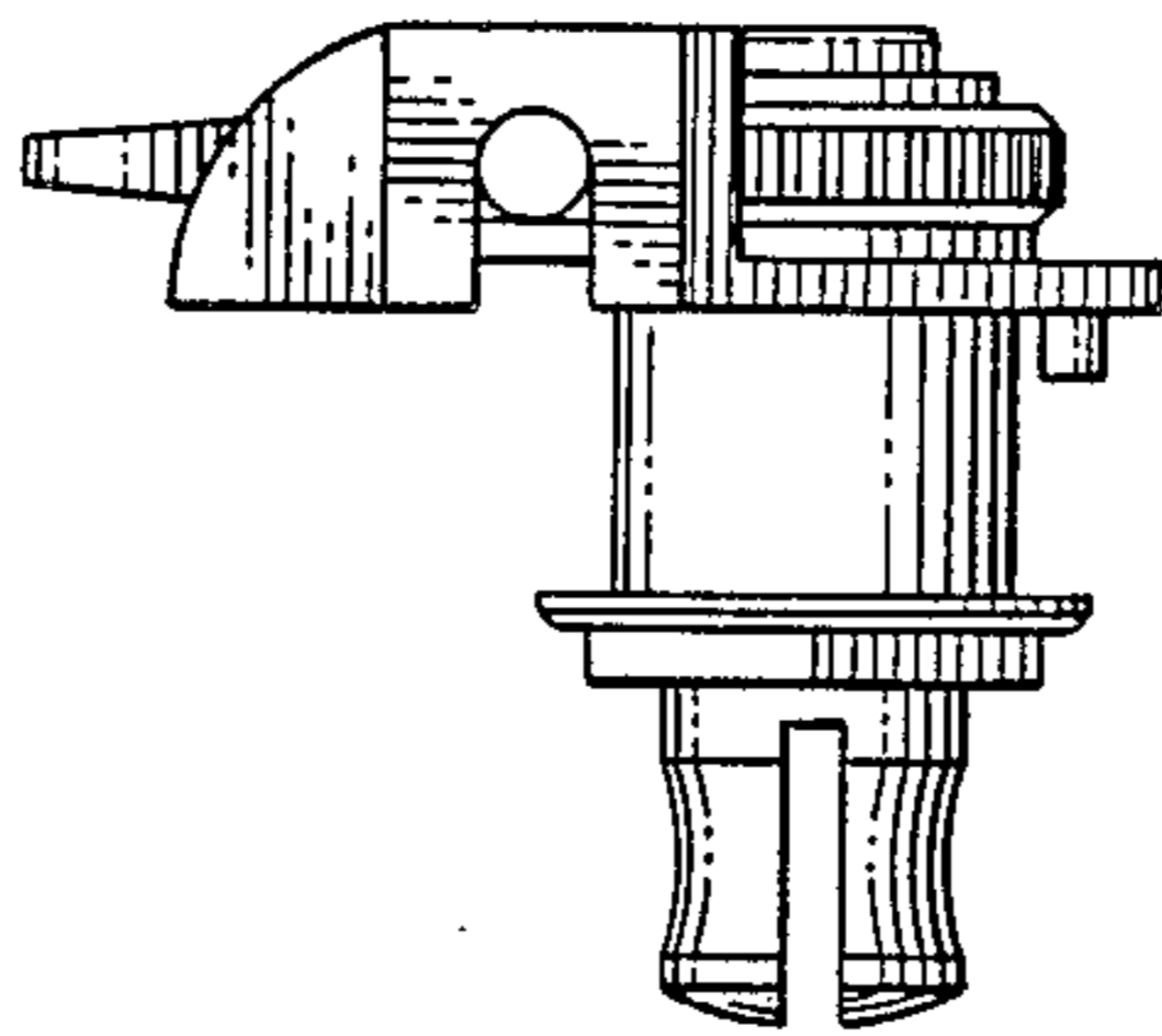

FIG. 6.

