

[54] **TERMINAL BLOCK ASSEMBLY FOR A LEADLESS MOTOR**

[75] Inventor: **Arthur C. Keck, Fort Wayne, Ind.**

[73] Assignee: **General Electric Company, Fort Wayne, Ind.**

[**] Term: **14 Years**

[21] Appl. No.: **155,625**

[22] Filed: **Feb. 12, 1988**

[52] U.S. Cl. **D13/146**

[58] Field of Search **D13/24, 30; 439/350, 439/660, 682, 685, 544, 550, 571, 572, 926; 310/71**

[56] **References Cited**

U.S. PATENT DOCUMENTS

3,012,159	8/1959	Druessedow	310/71
3,283,186	11/1966	Perry	310/71
3,399,374	8/1968	Pauza et al.	339/91
3,501,736	3/1970	Norris	339/91
3,502,917	3/1970	Bizoe	310/71
3,518,616	6/1970	Lewis	339/107
3,983,428	9/1976	Bitsch et al.	310/71
3,984,712	10/1976	Hill	310/71

4,213,070	7/1980	Lund et al.	310/71
4,429,243	1/1984	Crow	310/71
4,523,117	6/1985	Daniels	310/71
4,585,964	4/1986	Hildebrandt	310/71
4,655,527	4/1987	Vandame	439/350
4,677,330	6/1987	Watanabe et al.	310/154
4,727,274	2/1988	Adam et al.	310/239
4,748,355	5/1988	Anderson et al.	310/71

FOREIGN PATENT DOCUMENTS

0041746	4/1981	Japan	310/71
---------	--------	-------	--------

Primary Examiner—Susan J. Lucas
Assistant Examiner—Joel Sincavage
Attorney, Agent, or Firm—Ralph E. Krisher, Jr.

[57] **CLAIM**

The ornamental design for a terminal block assembly for a leadless motor, as shown and described.

DESCRIPTION

FIG. 1 is a front elevational view of a terminal block assembly for a leadless motor showing my new design. FIG. 2 is a left side elevational view thereof. FIG. 3 is a top plan view thereof. FIG. 4 is a right side elevational view thereof. FIG. 5 is a rear elevational view thereof. FIG. 6 is a bottom plan view thereof.

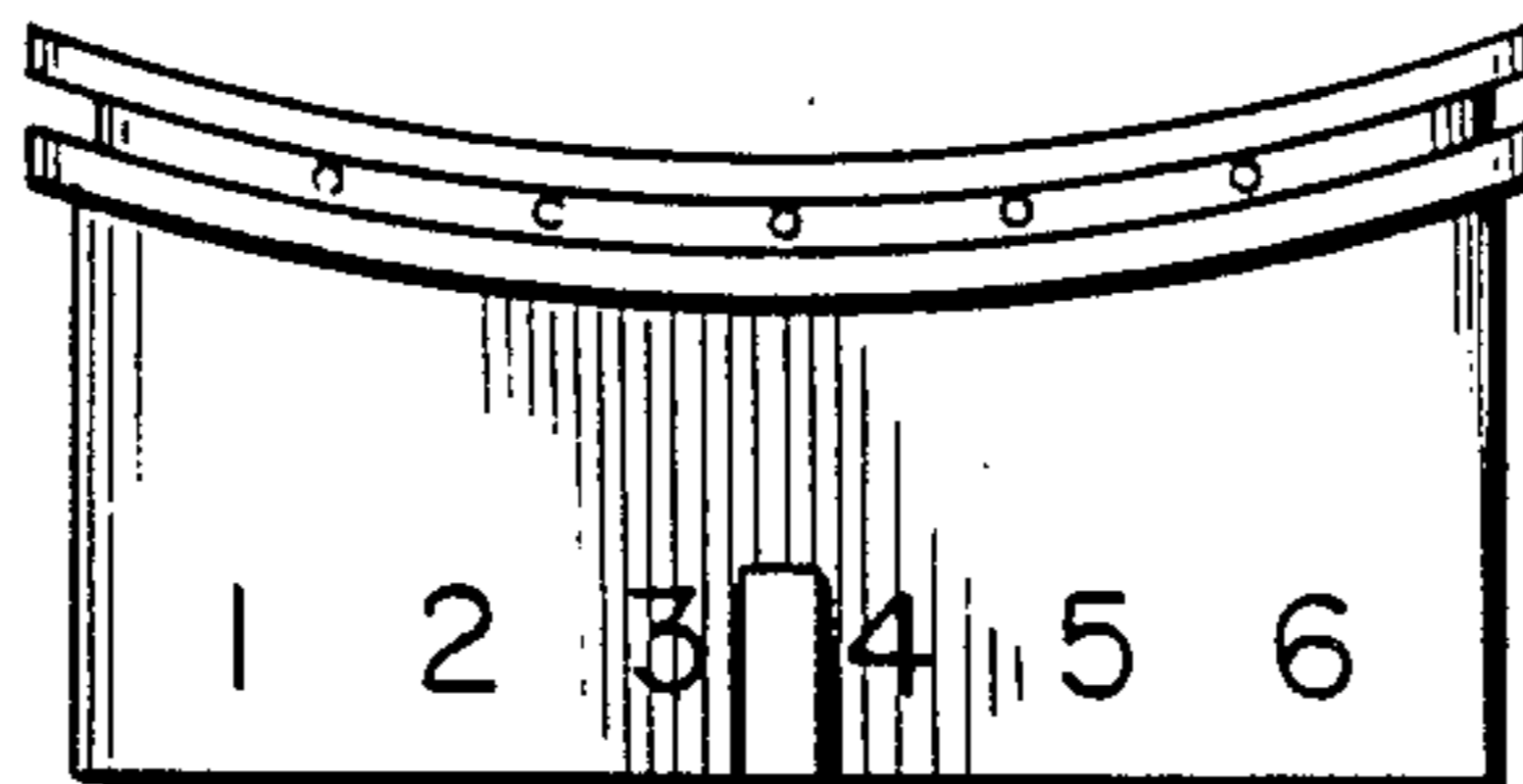
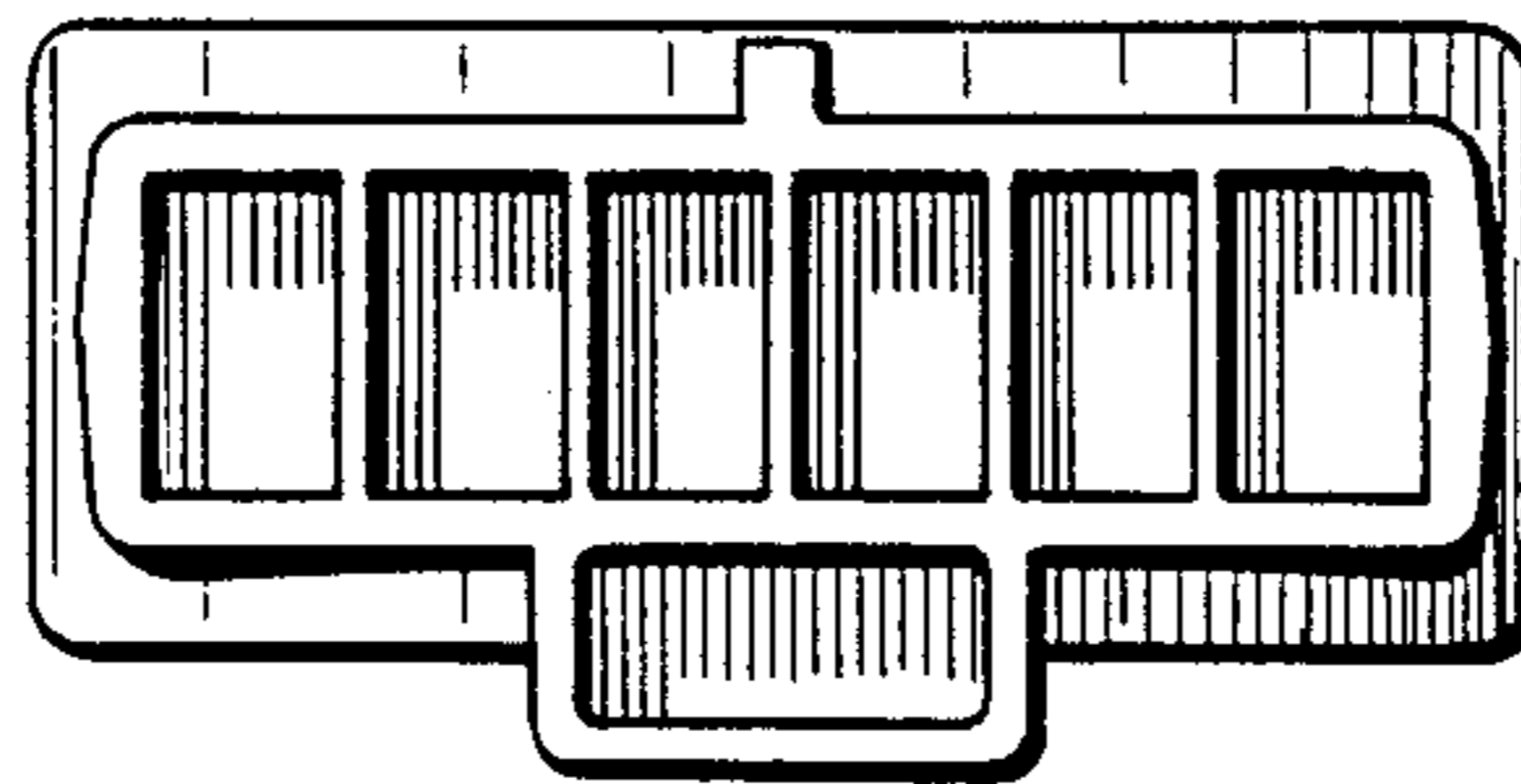

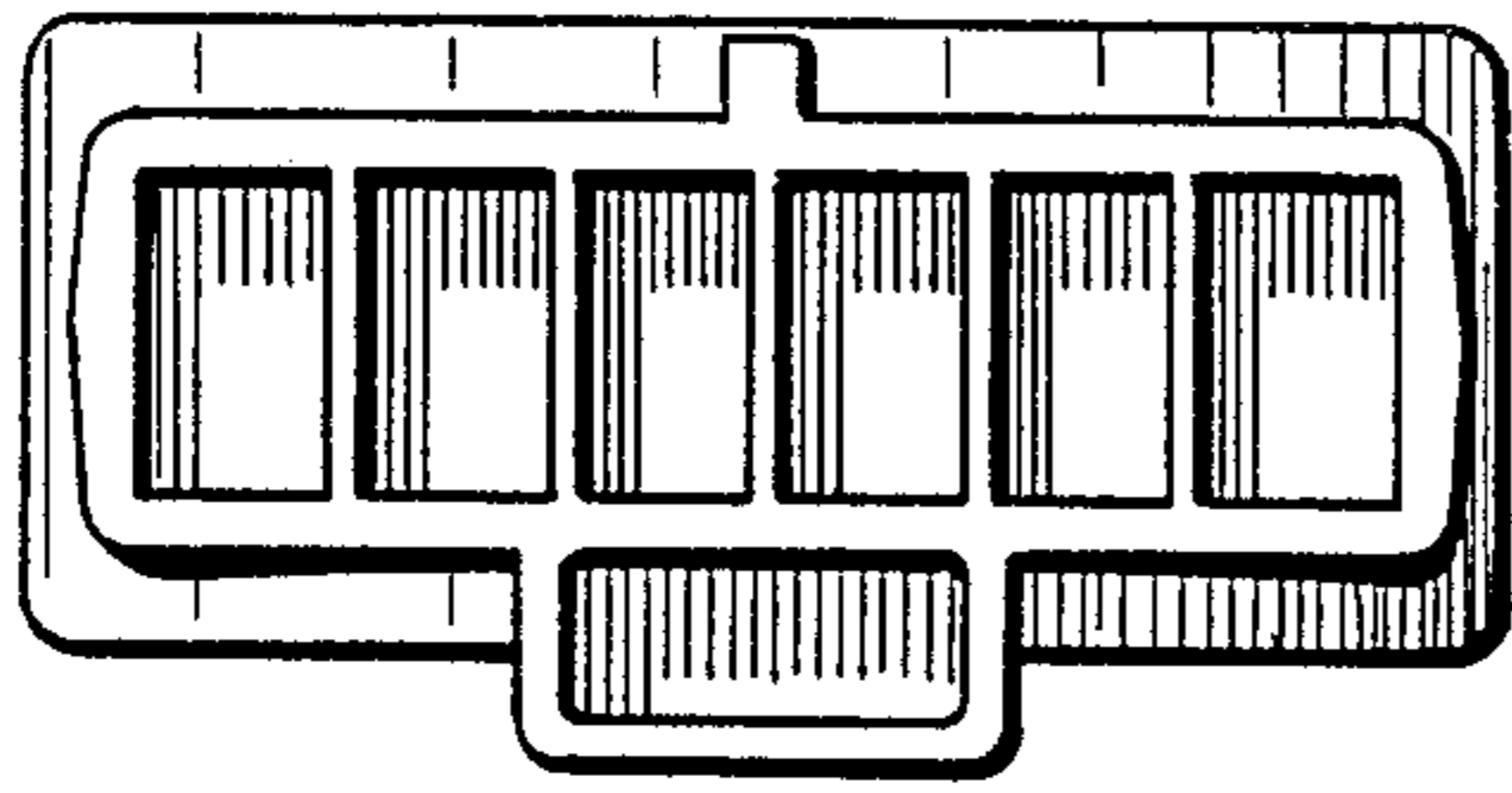

FIG. 1

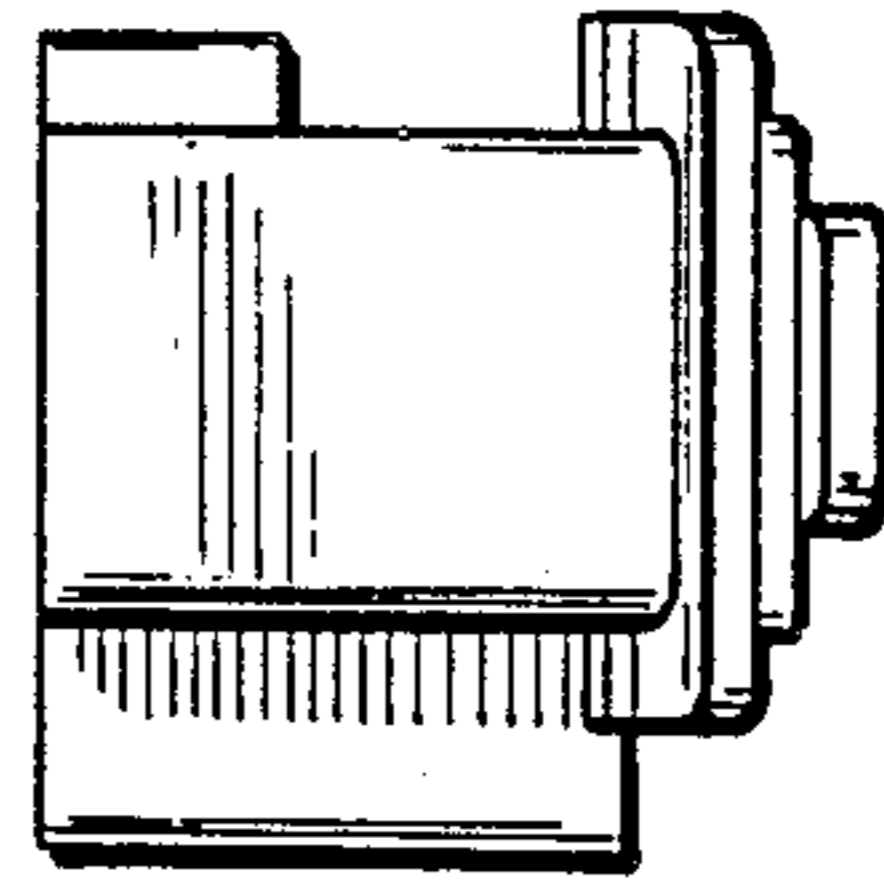

FIG. 2

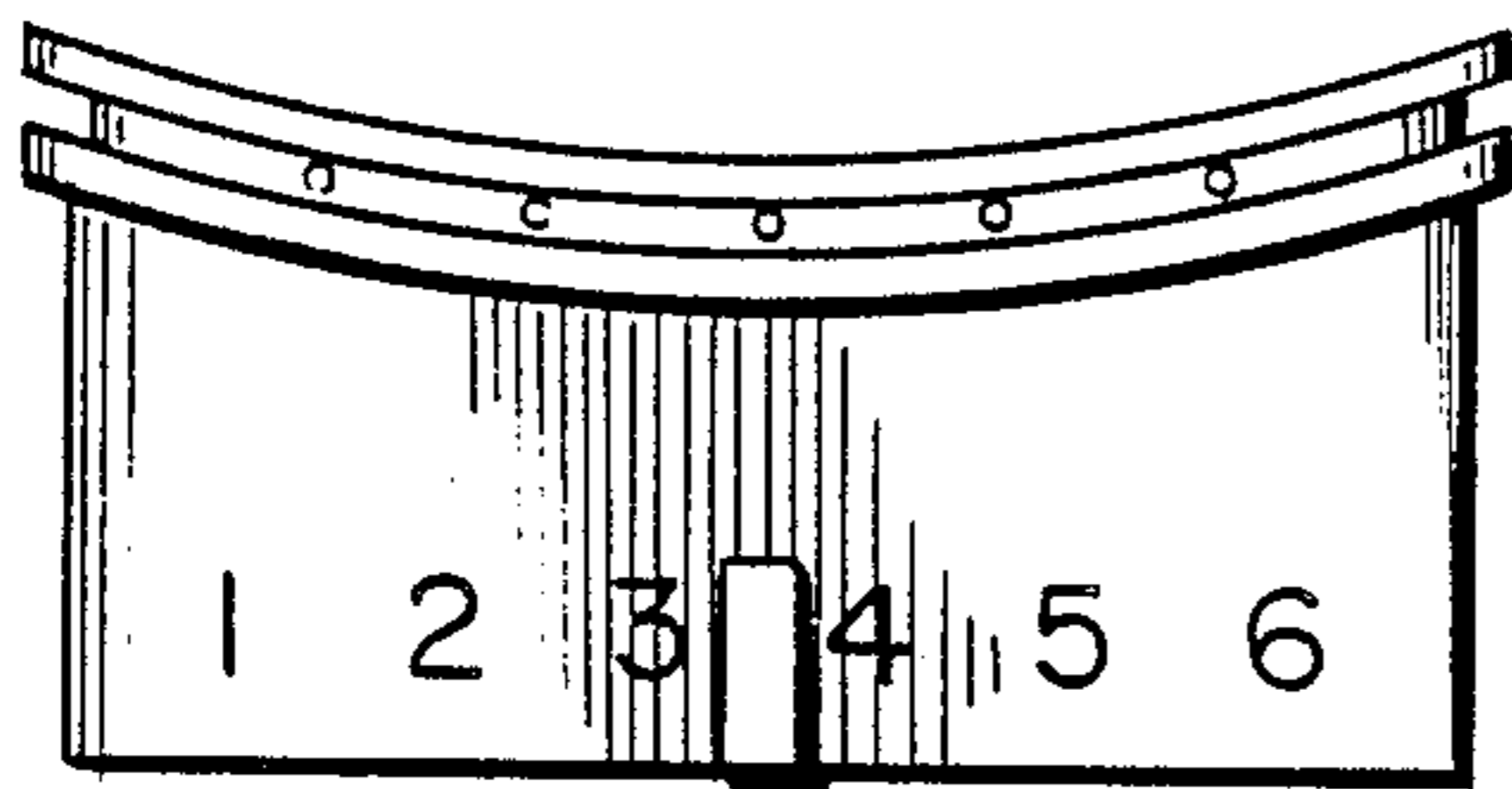

FIG. 3

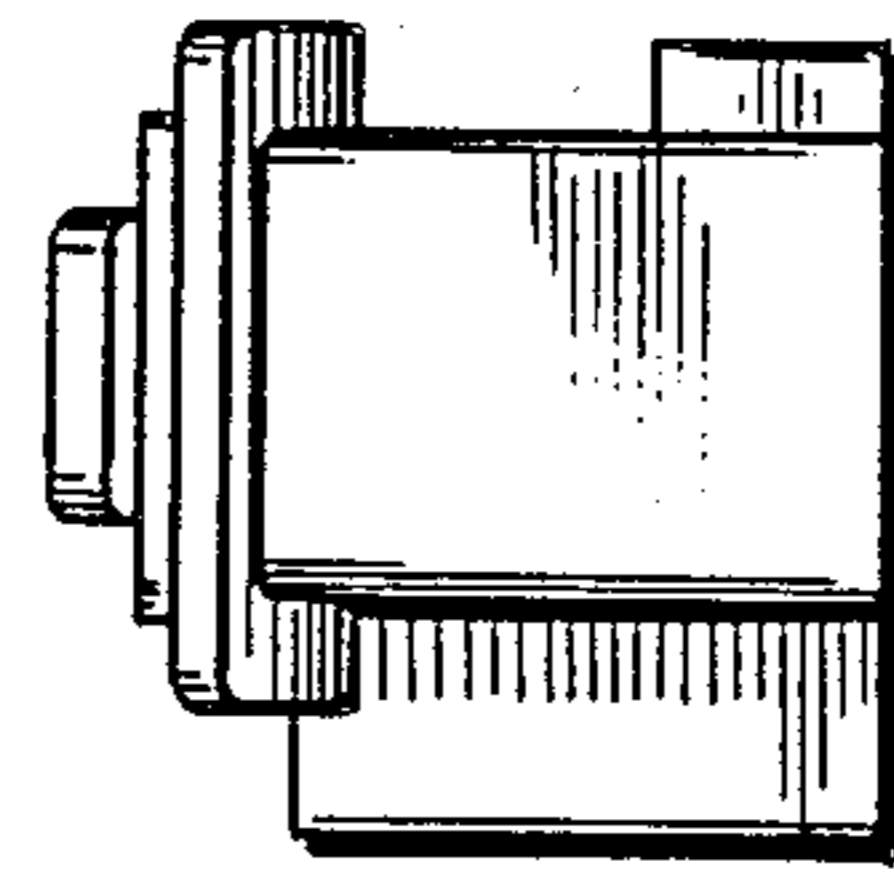

FIG. 4

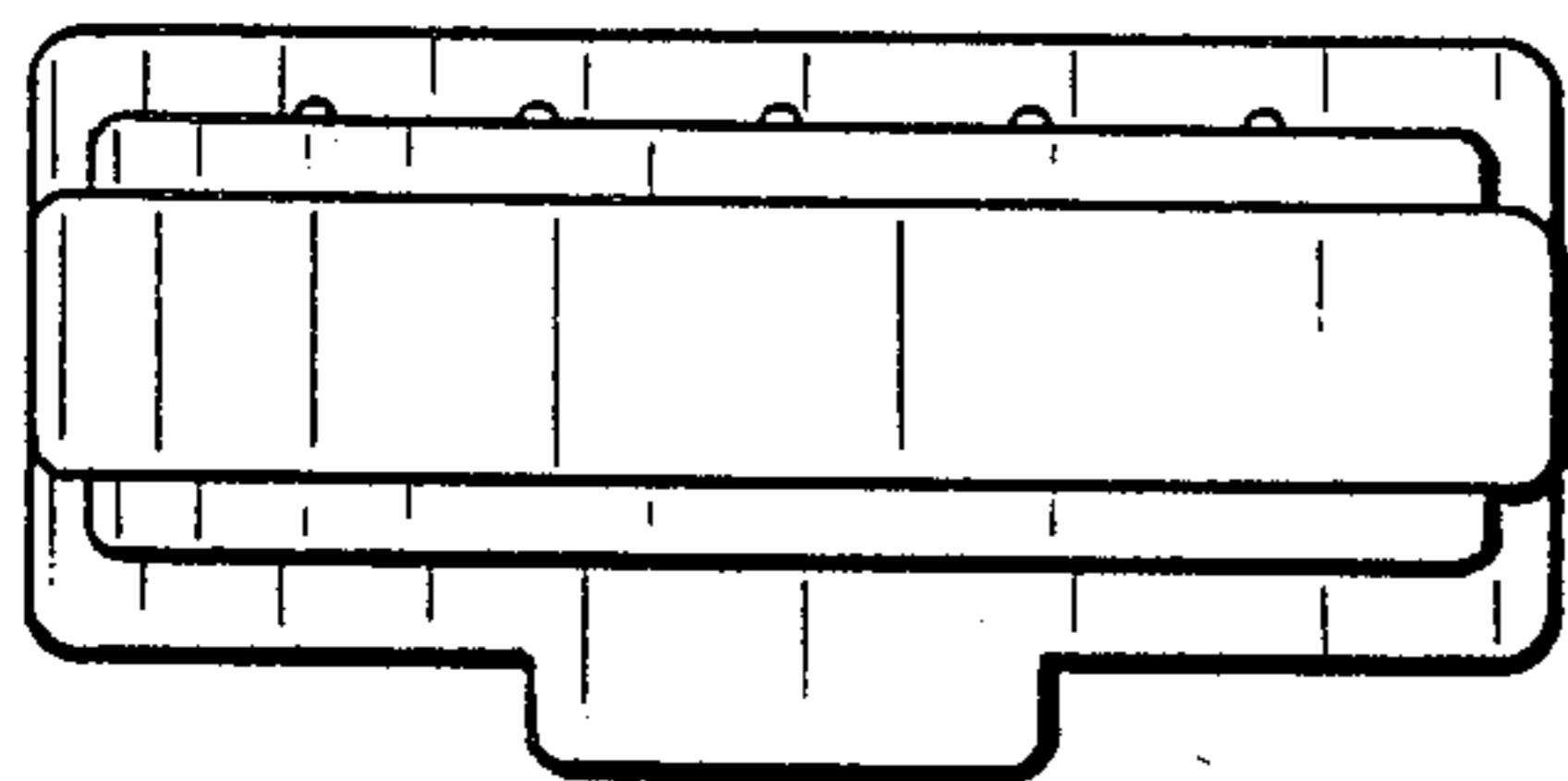

FIG. 5

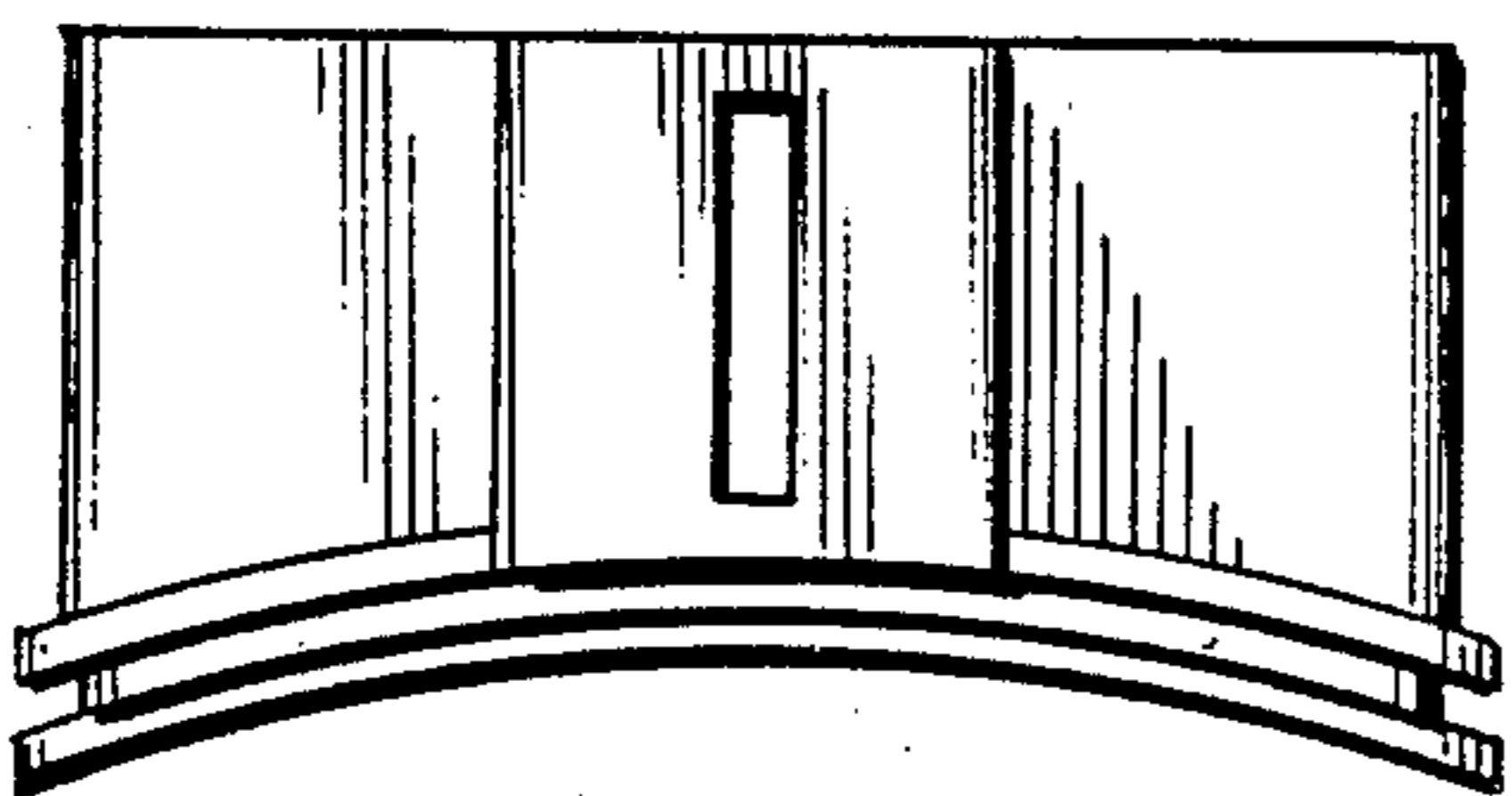

FIG. 6