

United States Patent [19]

Wood

[11] Patent Number: **Des. 311,364**

[45] Date of Patent: **** Oct. 16, 1990**

[54] **ARM REST ENGAGABLE MOUNTING BRACKET**

[76] Inventor: **Charles F. Wood, 8341 W. Foothill Dr., Peoria, Ariz. 85345**

[**] Term: **14 Years**

[21] Appl. No.: **12,636**

[22] Filed: **Feb. 9, 1987**

[52] U.S. Cl. **D12/133; D8/354**

[58] Field of Search **D12/133, 128; D8/354; 248/283, 118, 321; 297/412, 194; 108/141**

[56] **References Cited**

U.S. PATENT DOCUMENTS

598,895	2/1898	Bell	108/141
1,664,835	4/1928	Stevens	108/142
2,433,570	12/1947	Markkula	403/95
2,602,488	7/1952	Conning	248/118
4,332,363	6/1982	Ware	248/321

4,807,935	2/1989	King	297/412
4,815,688	3/1989	Wood	248/283
4,822,103	4/1989	Stenvall	297/412

FOREIGN PATENT DOCUMENTS

117294 9/1946 Sweden .

Primary Examiner—Kay H. Chin

Attorney, Agent, or Firm—Cahill, Sutton & Thomas

[57] **CLAIM**

The ornamental design for an arm rest engagable mounting bracket, as shown and described.

DESCRIPTION

FIG. 1 is a top and front perspective view of an arm rest engagable mounting bracket showing my new design; FIG. 2 is a right side elevational view thereof; FIG. 3 is a bottom plan view thereof; FIG. 4 is a left side elevational view thereof; and FIG. 5 is a rear elevational view thereof.

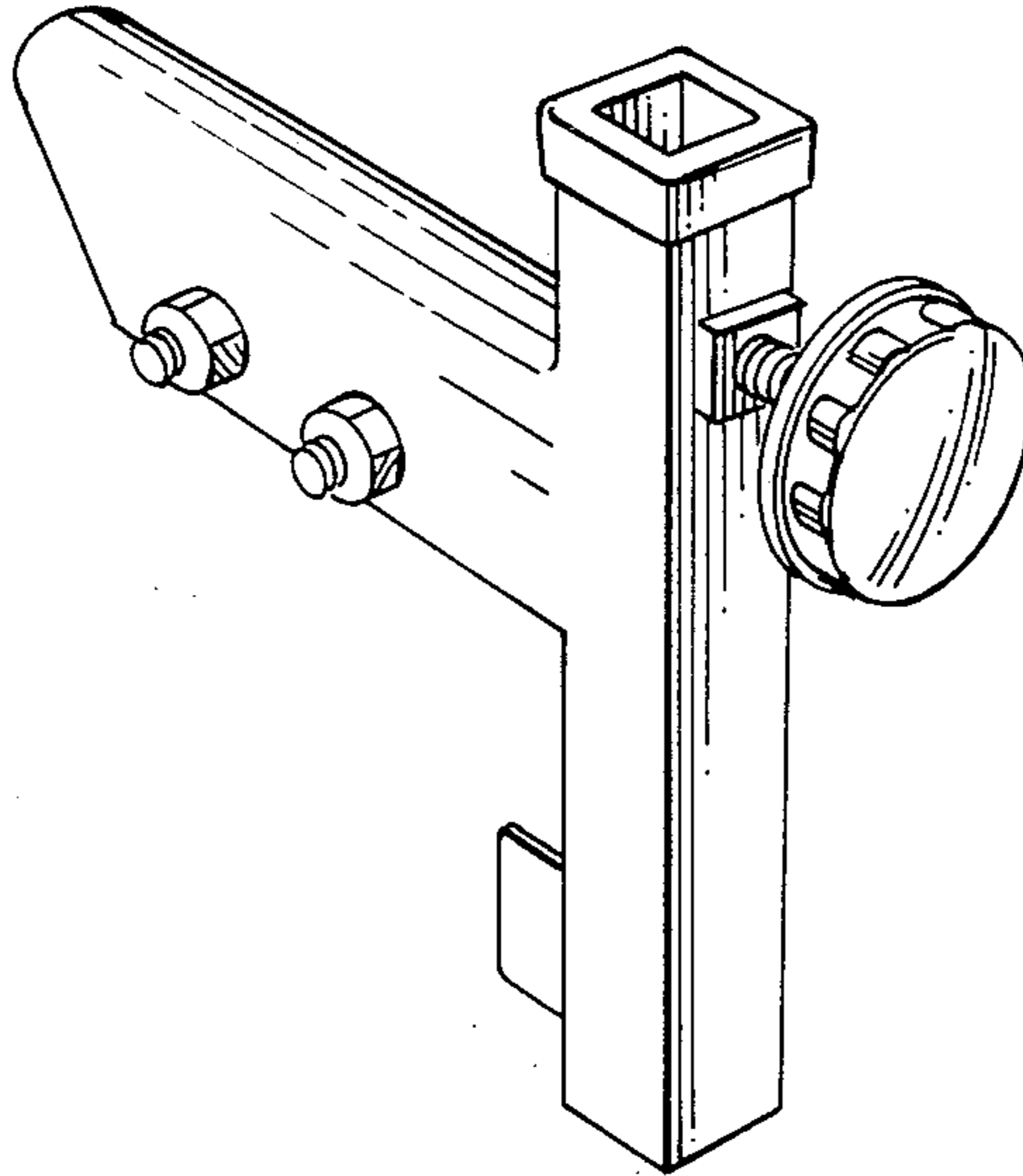

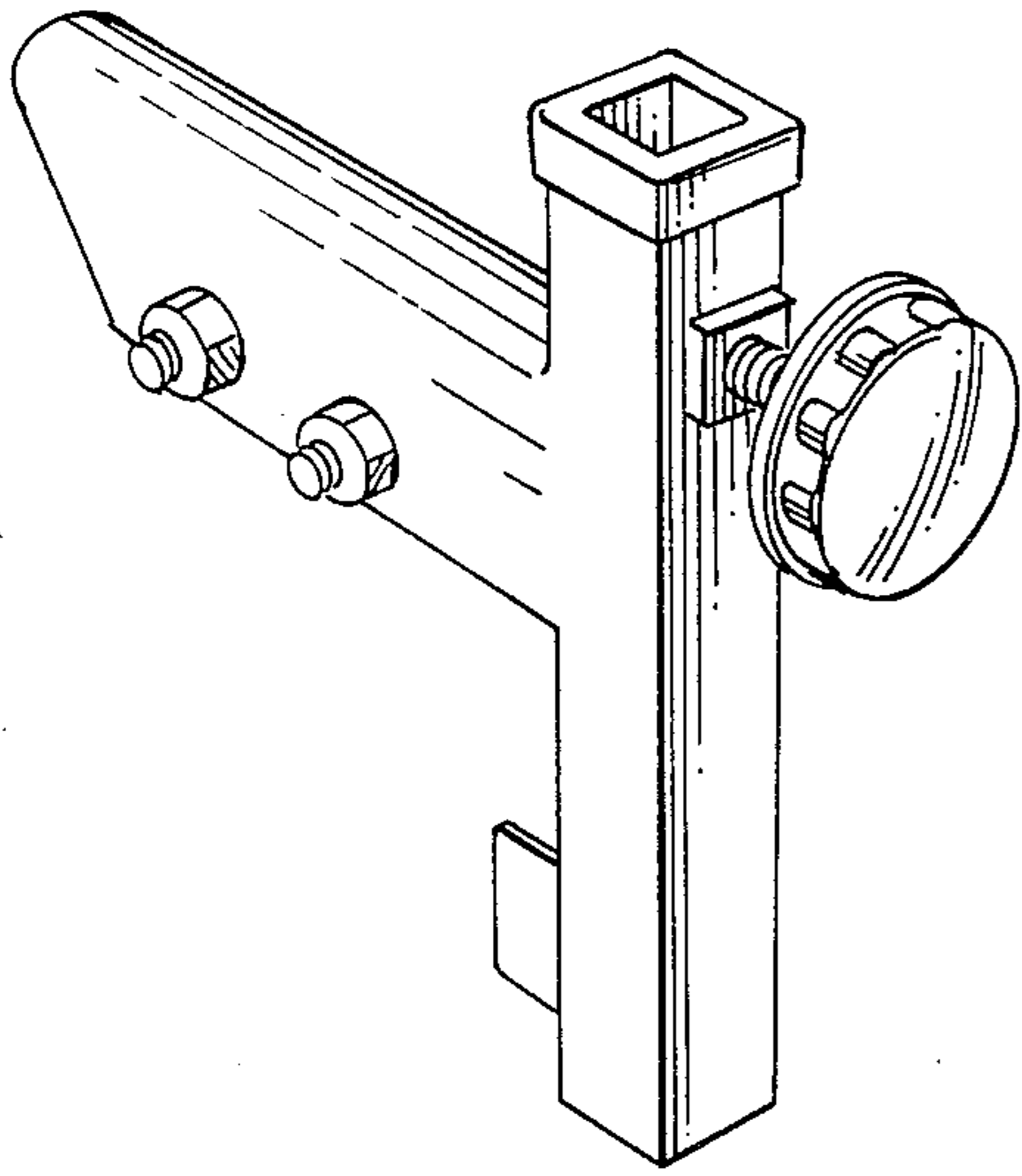

fig. 1

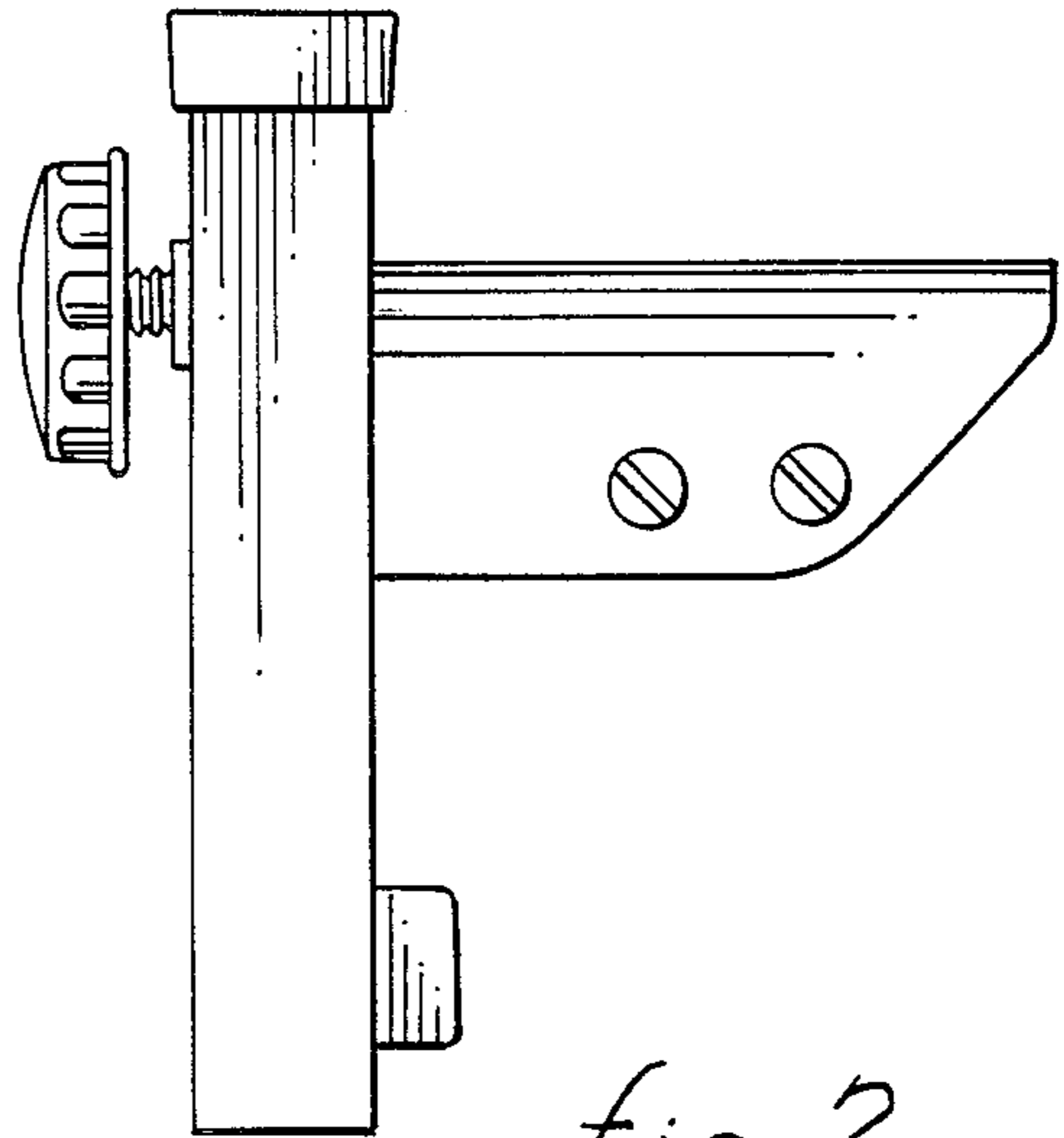

fig. 2

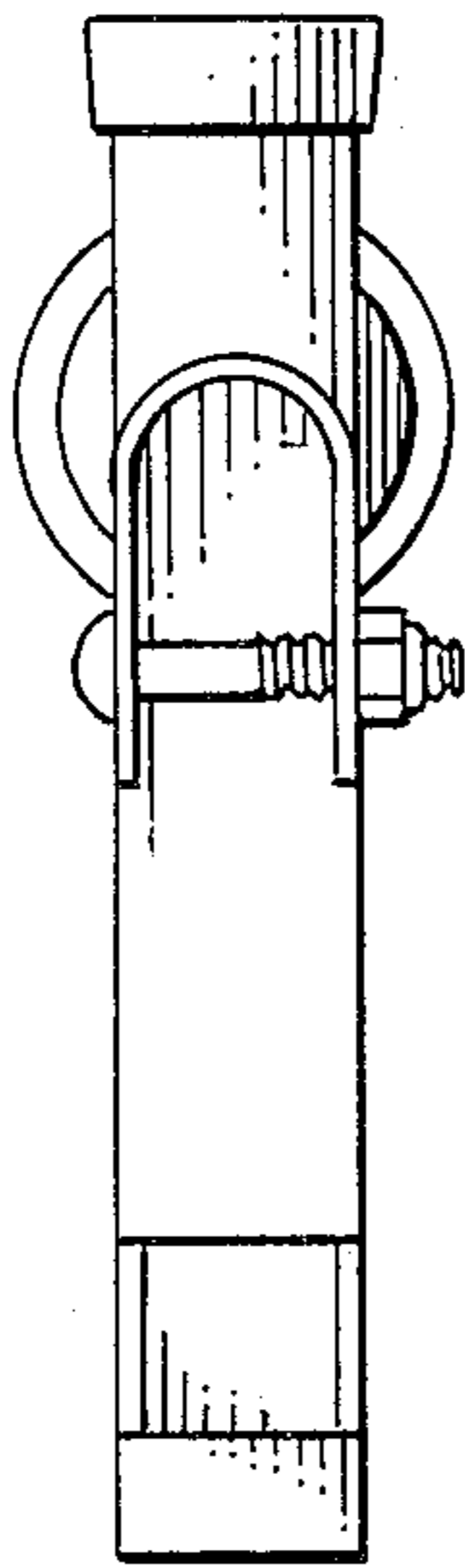

fig. 5

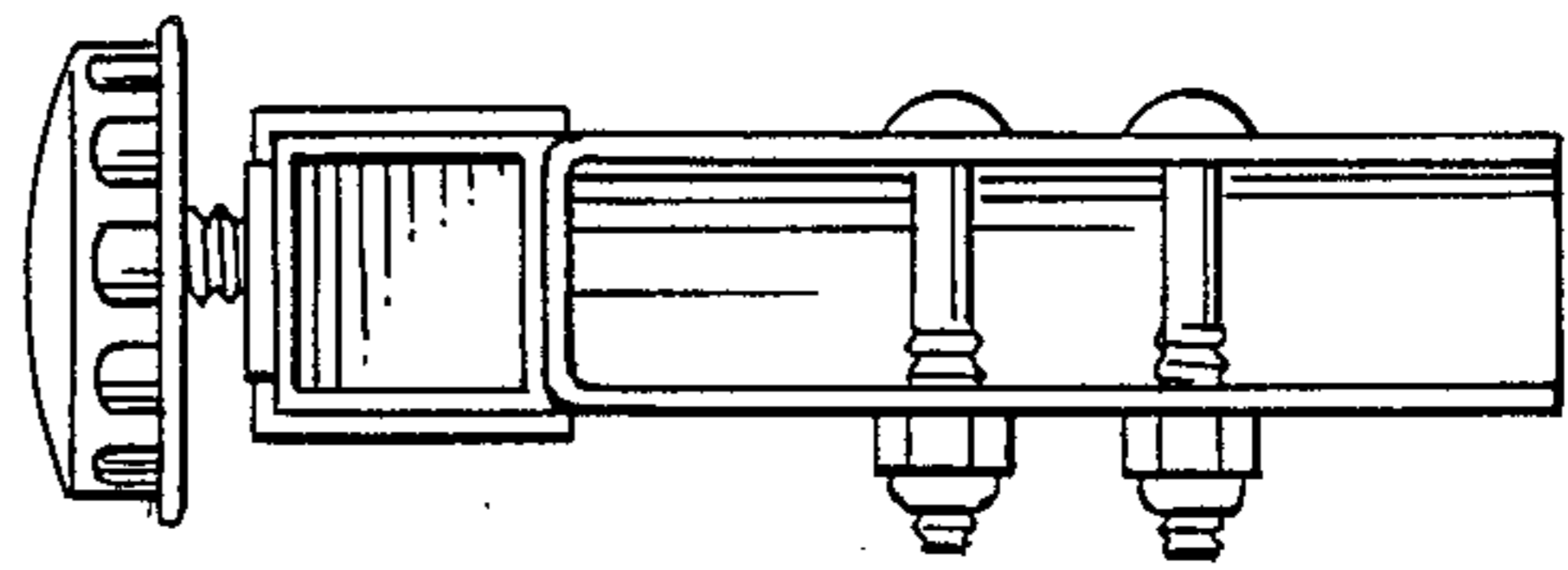

fig. 3

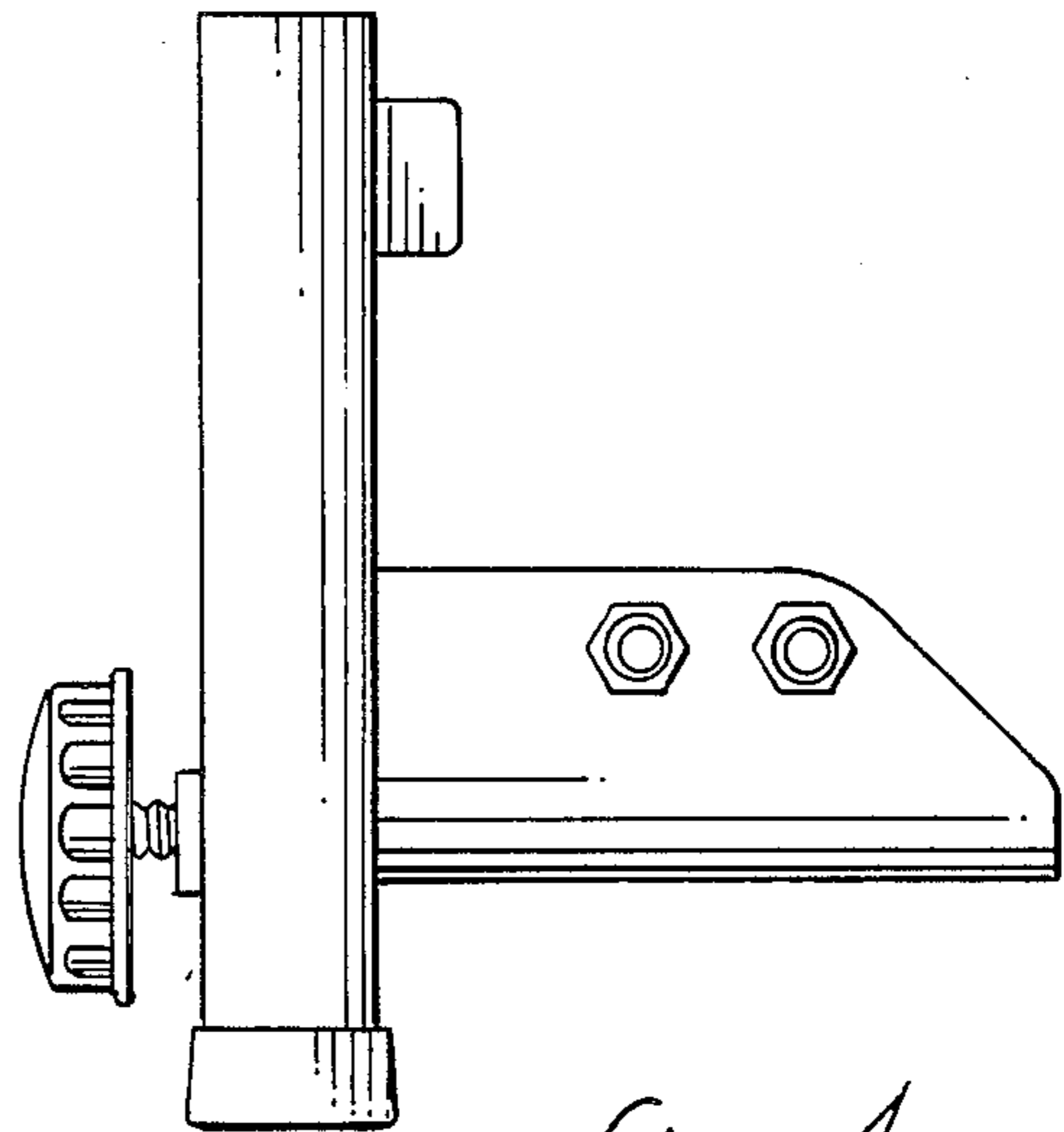

fig. 4