

[54] BABY CARRIAGE

[76] Inventor: Chih-Chung Lin, 265, Fu Hsing Rd., Shuh Lin Chen, Taipei Hsien, Taiwan

[**] Term: 14 Years

[21] Appl. No.: 183,034

[22] Filed: Apr. 18, 1988

[30] Foreign Application Priority Data

Aug. 21, 1987 [TW] Taiwan76305048

[52] U.S. Cl. D12/129

[58] Field of Search D12/128, 129; 280/642, 280/650, 658, 47.4, 647, 643, 644, 30, 42; 297/45, 39

[56] References Cited

U.S. PATENT DOCUMENTS

- D. 138,468 8/1944 Call D12/129
- D. 145,468 8/1946 Spence D12/129

- D. 296,540 7/1988 Perego D12/129
- 1,707,186 3/1929 Chatfield D12/128
- 4,542,915 9/1985 Wheeler, III et al. D12/129

Primary Examiner—Wallace R. Burke
Assistant Examiner—Kay H. Chin
Attorney, Agent, or Firm—Varndell Legal Group

[57] CLAIM

The ornamental design for a baby carriage, as shown and described.

DESCRIPTION

FIG. 1 is a front and left side perspective view of a baby carriage showing my new design;
FIG. 2 is a left side elevational view thereof, the right side view being a mirror image of that shown;
FIG. 3 is a top plan view thereof;
FIG. 4 is a front elevational view thereof;
FIG. 5 is a rear elevational view thereof;
FIG. 6 is a bottom plan view thereof.

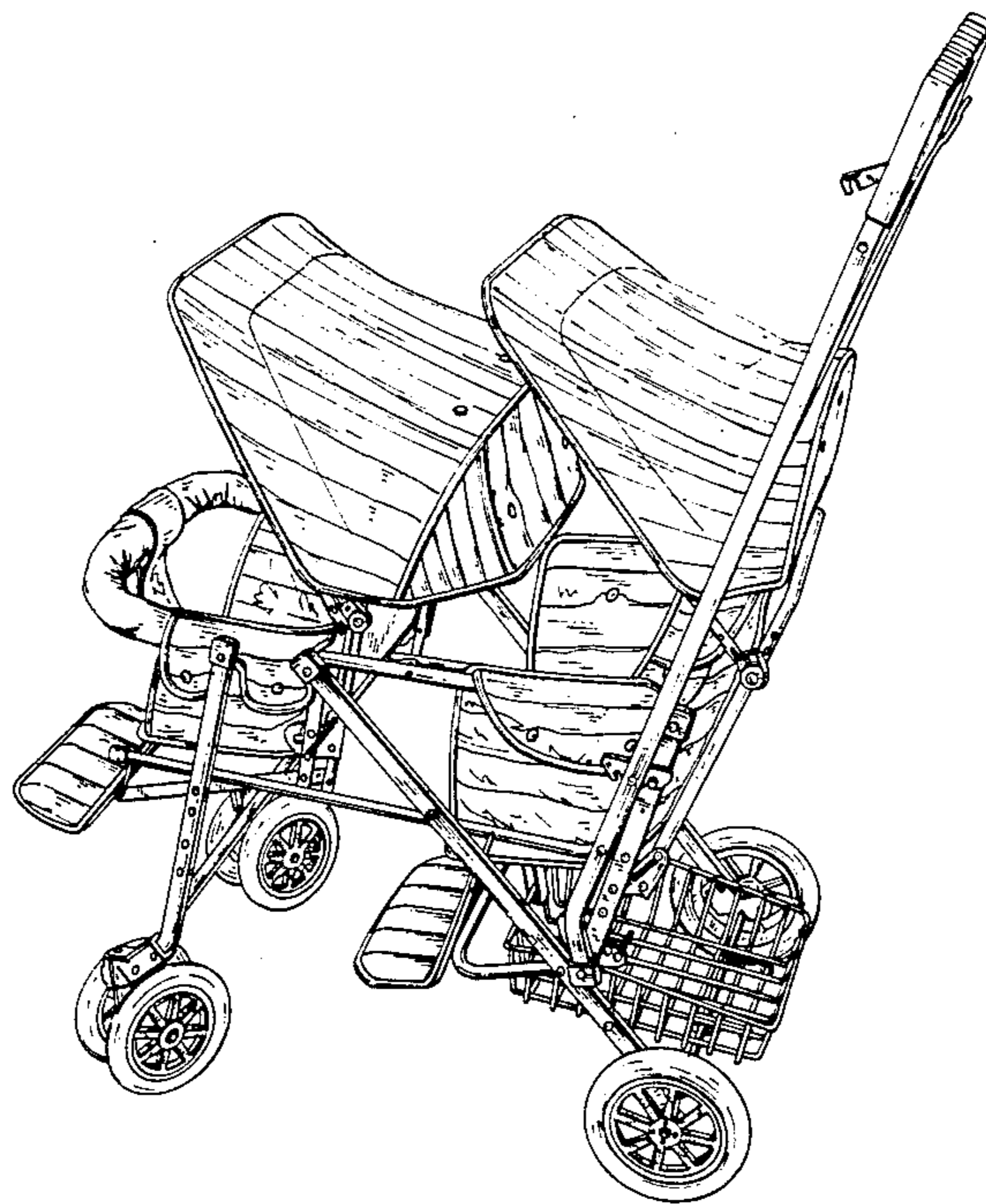

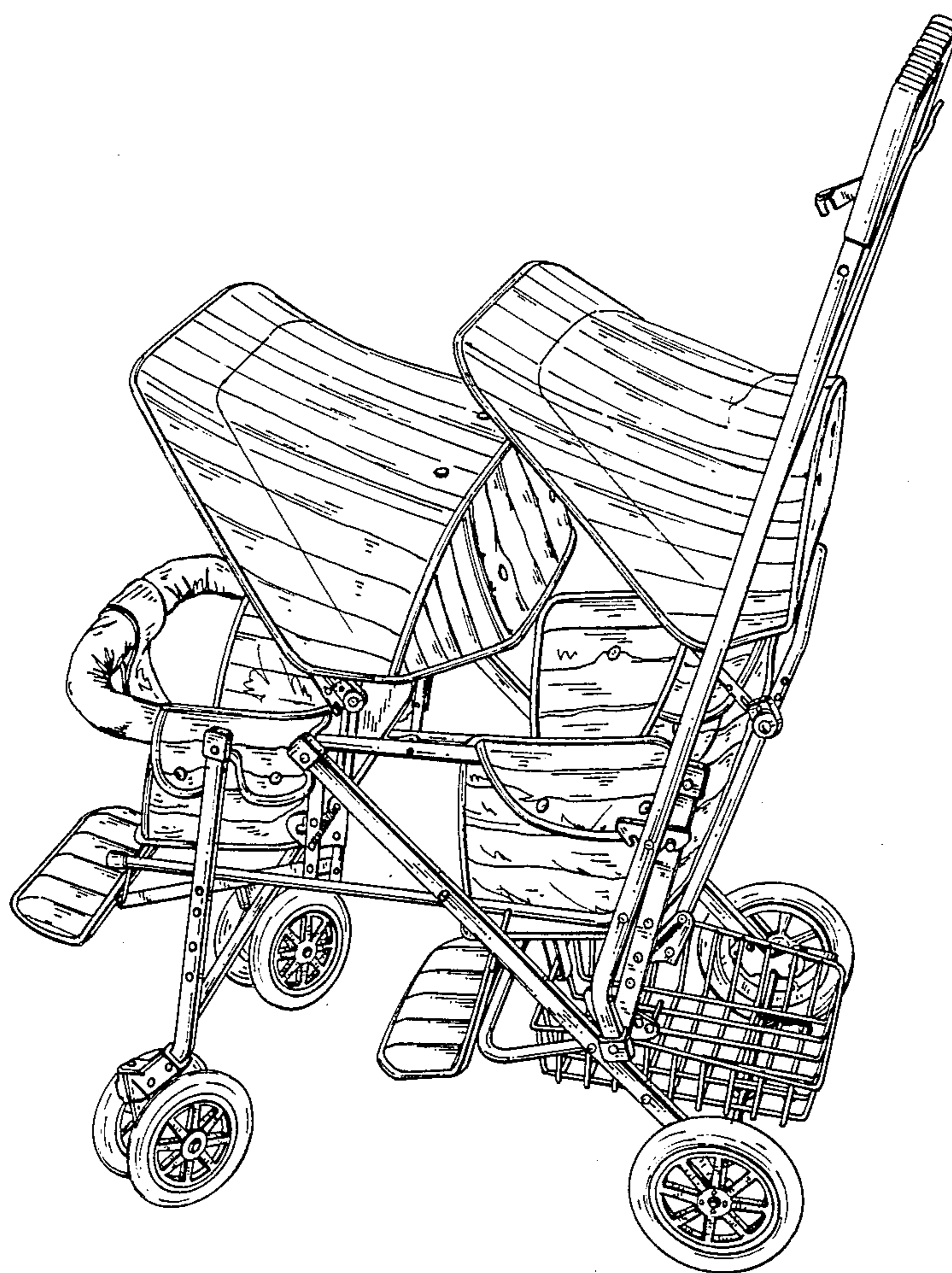

Fig. 1

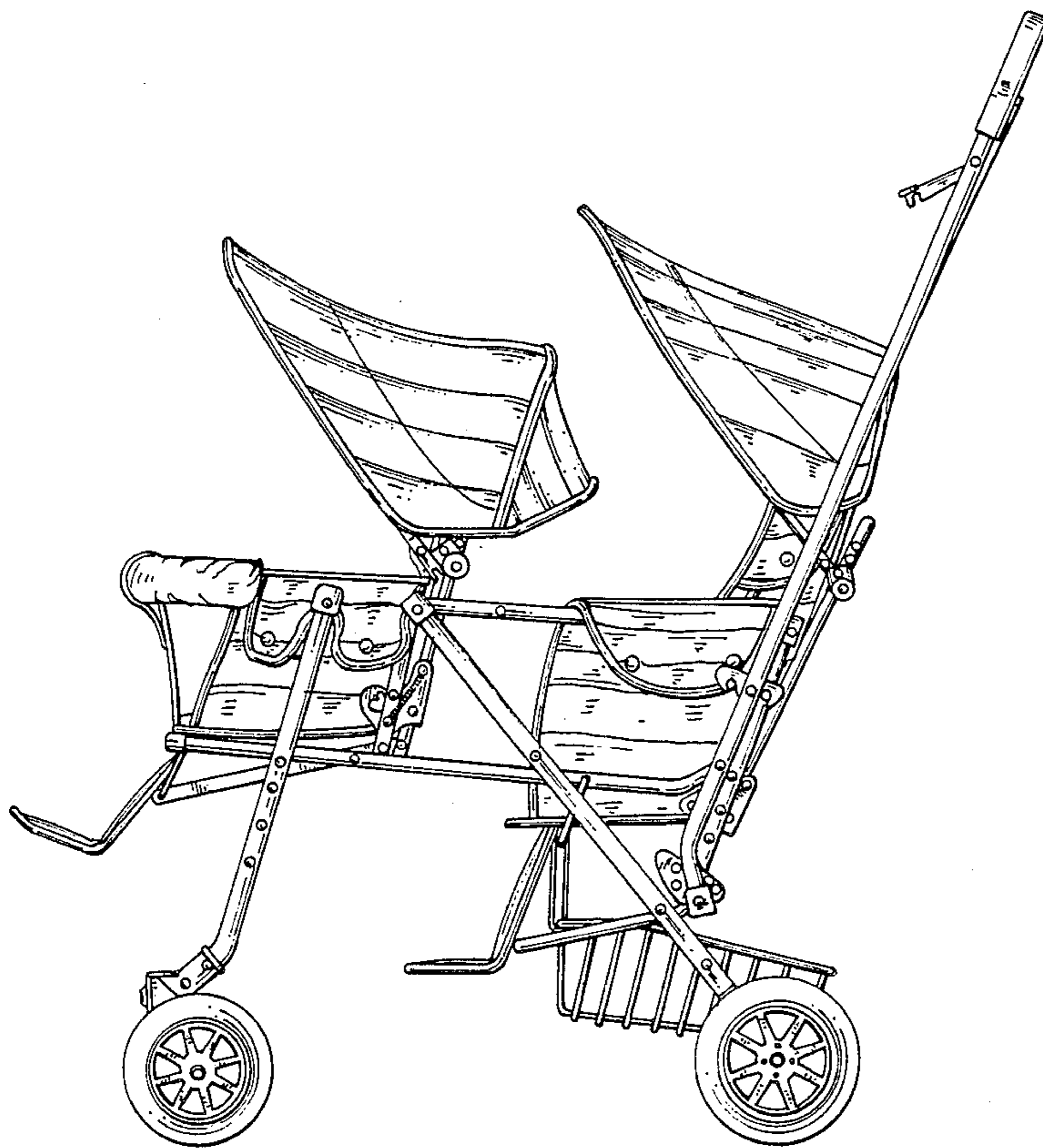

Fig. 2

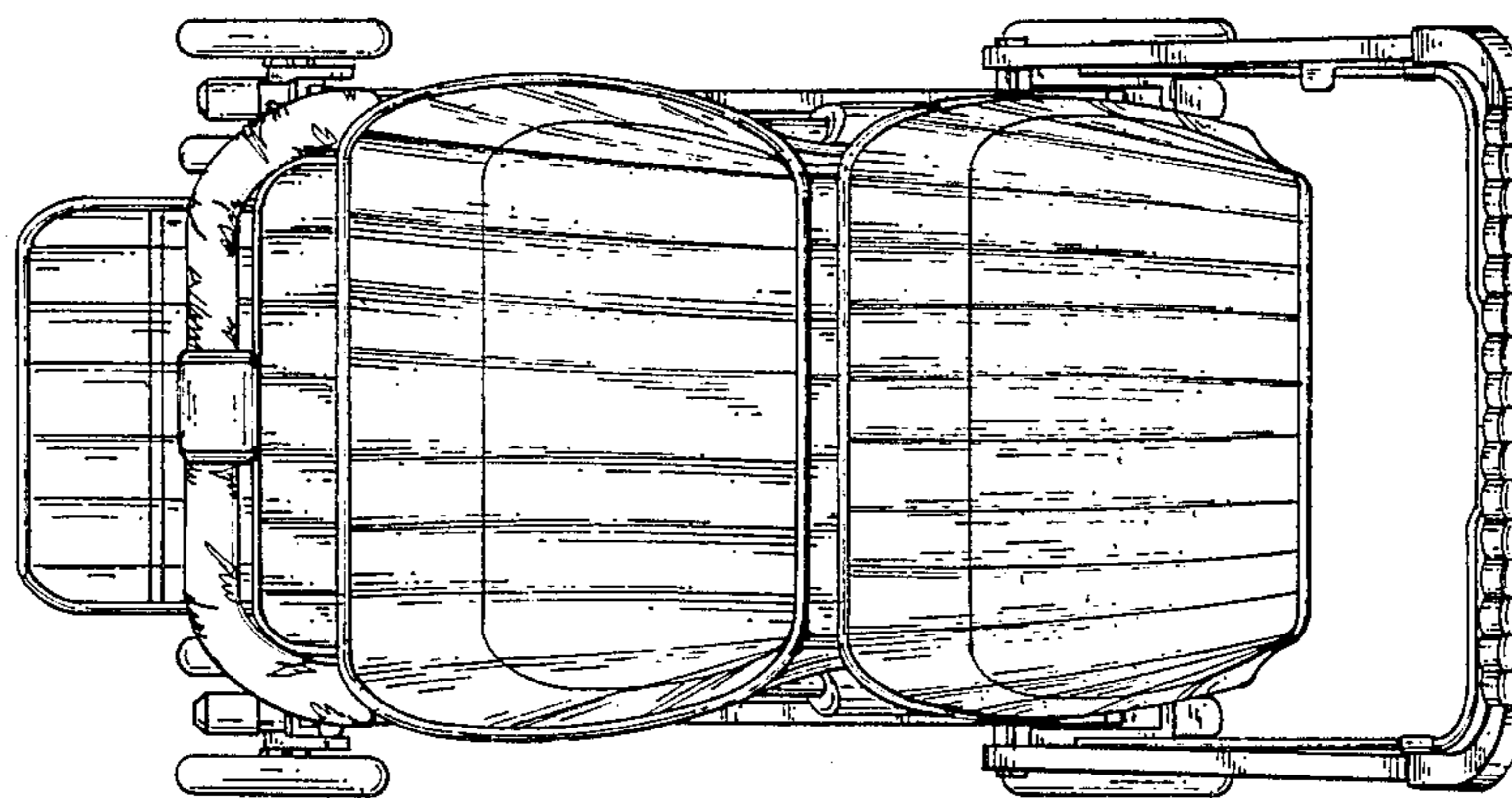

Fig. 3

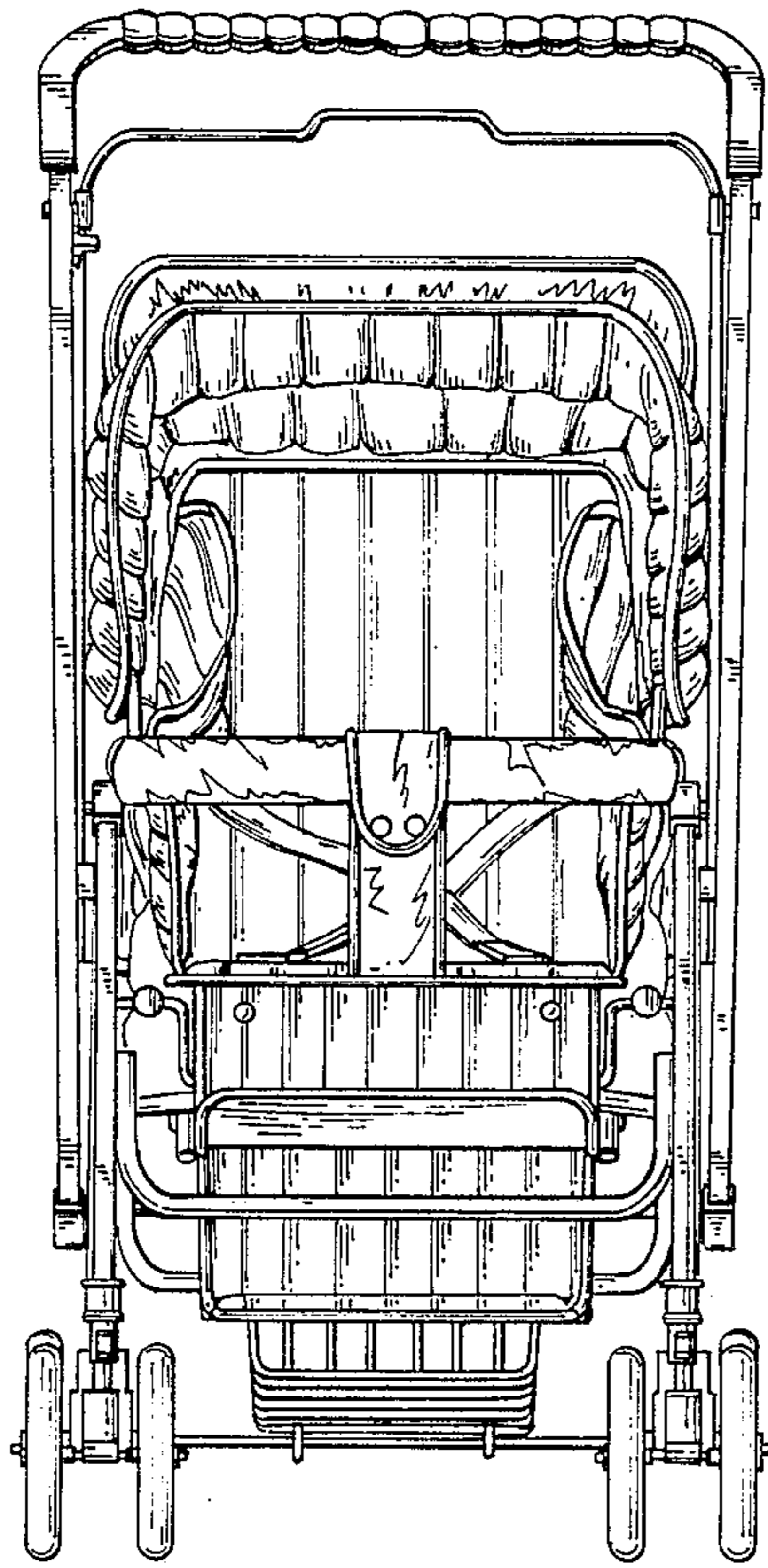

Fig. 4

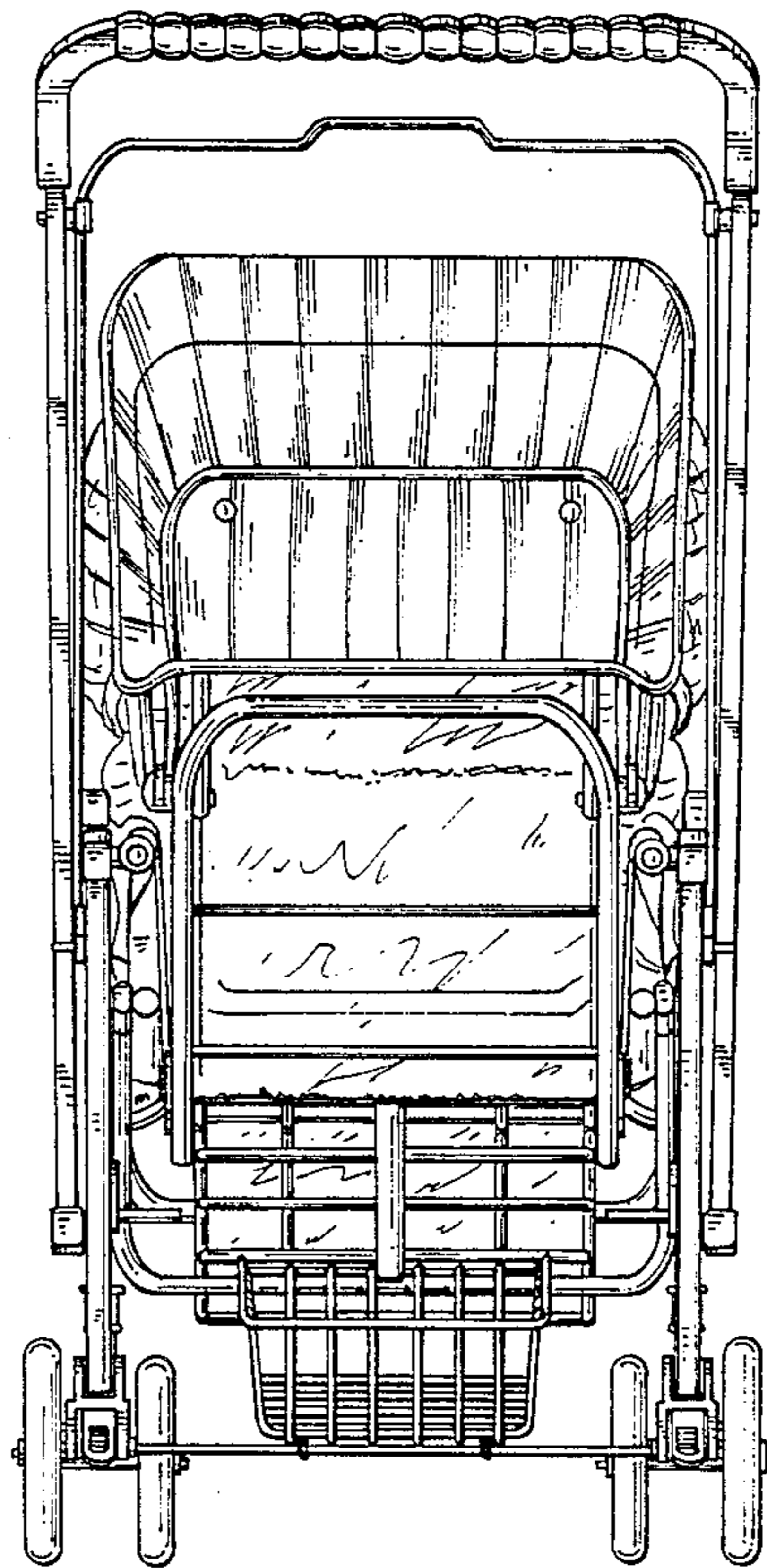

Fig. 5

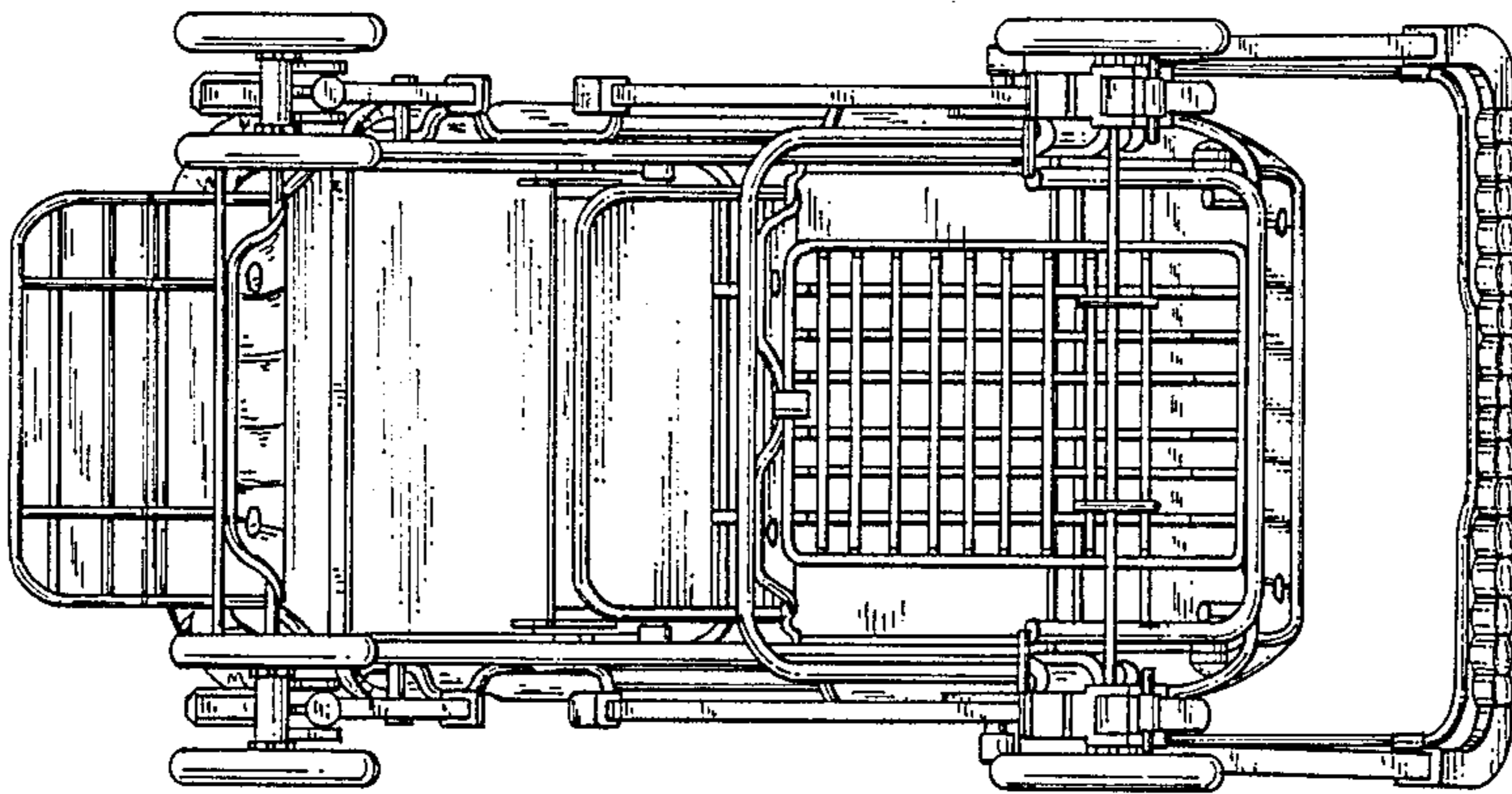

Fig. 6