

[54] **AUTOMOBILE**

[75] **Inventors:** Yoshinao Fujimura, Kodaira; Taro Ueda; Yusuke Saitoh, both of Tokyo, Japan

[73] **Assignee:** Honda Giken Kogyo Kabushiki Kaisha, Tokyo, Japan

[**] **Term:** 14 Years

[21] **Appl. No.:** 79,272

[22] **Filed:** Jul. 29, 1987

[30] **Foreign Application Priority Data**

Jan. 30, 1987 [JP] Japan 62-3357

[52] **U.S. Cl.** D12/92

[58] **Field of Search** D12/91, 92; 296/185

[56] **References Cited**

U.S. PATENT DOCUMENTS

D. 276,600 12/1984 Nakano et al. D12/92

D. 298,522 11/1988 Nakano et al. D12/92

OTHER PUBLICATIONS

Motor Trend, 8/85, p. 51, Honda Accord, bottom of page.

Carina Ed Catalog, p. 26, Toyota Carina Ed Automobile, top of page.

Road & Track, 5/86, p. 36, Subaru Sedan, bottom left side of page.

Motor Trend, 7/86, p. 22, Acura Legend, top of page.

Primary Examiner—James M. Gandy

Attorney, Agent, or Firm—Lyon & Lyon

[57] **CLAIM**

The ornamental design for an automobile, as shown.

DESCRIPTION

FIG. 1 is a top plan view of the automobile showing our new design;

FIG. 2 is a right side elevation view thereof;

FIG. 3 is a front elevation view thereof;

FIG. 4 is a rear elevation view thereof;

FIG. 5 is a left side elevation view thereof.

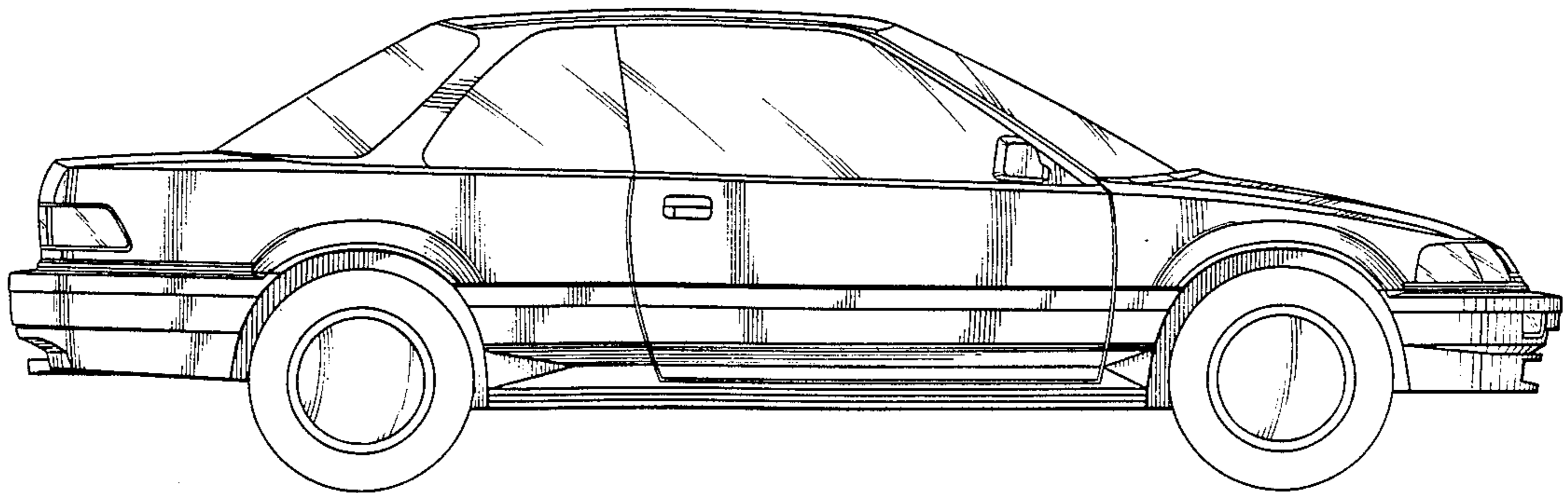

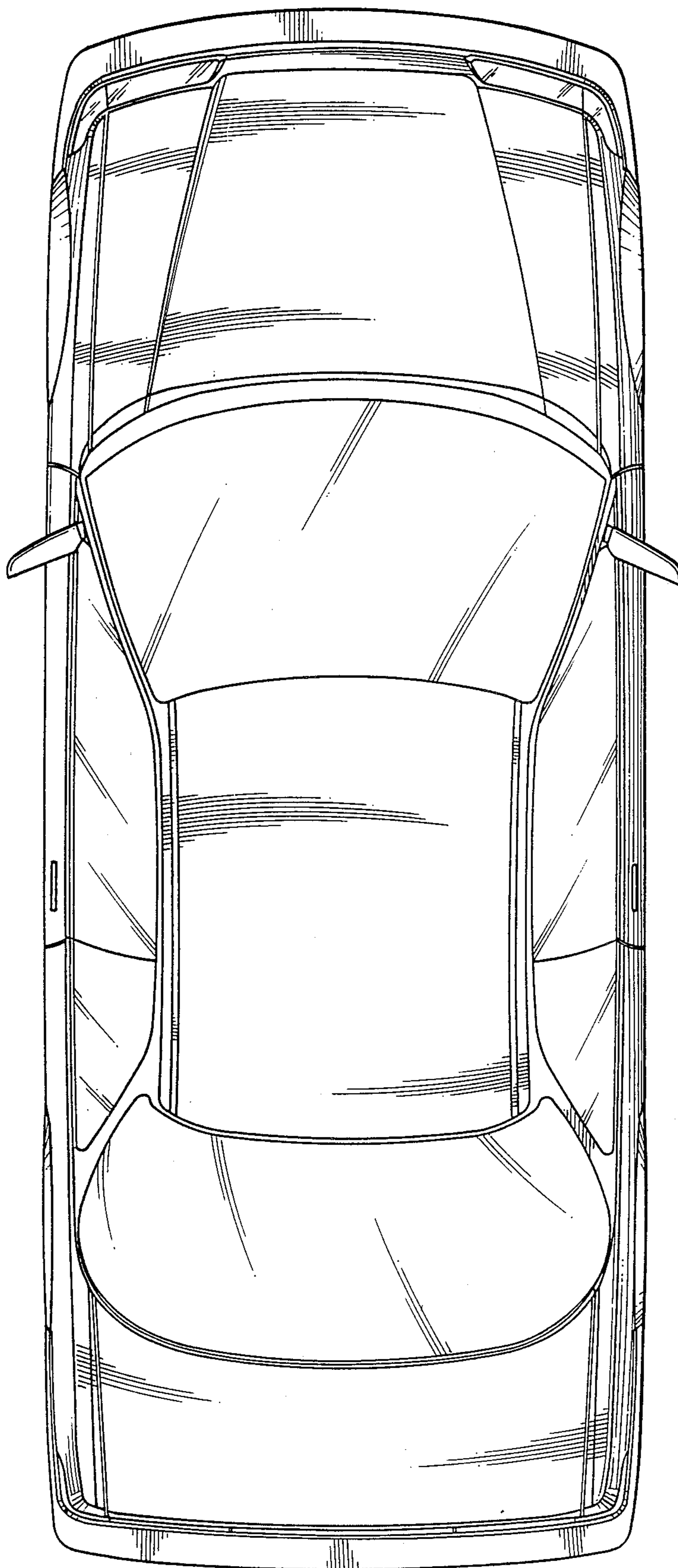

FIG. 1.

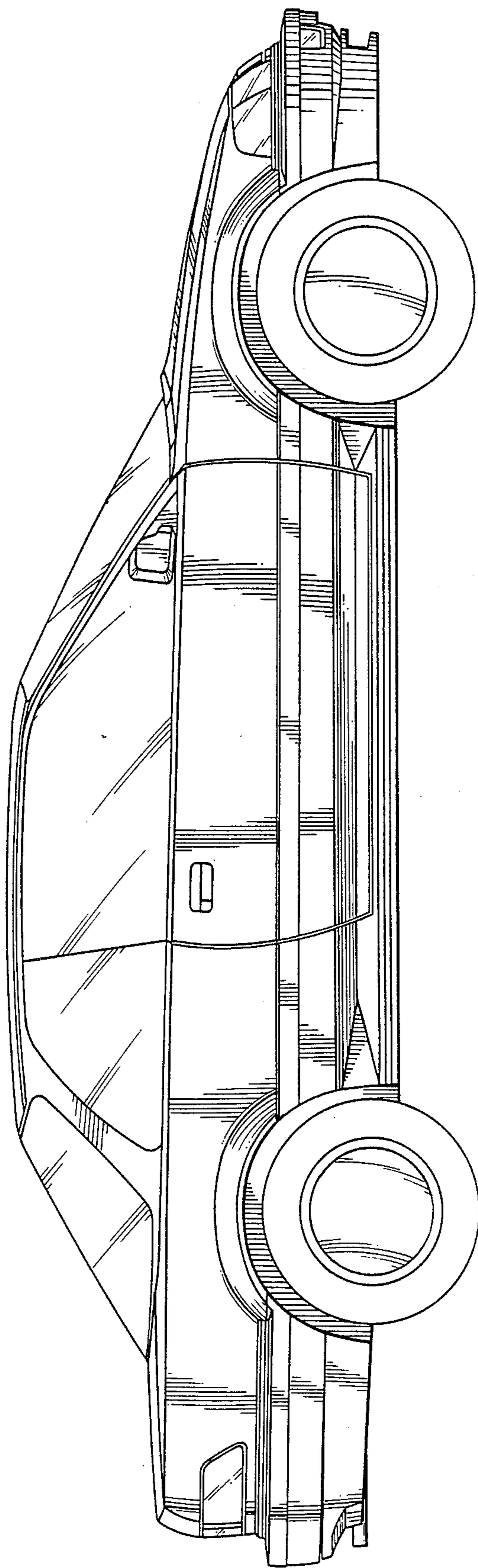

FIG. 2.

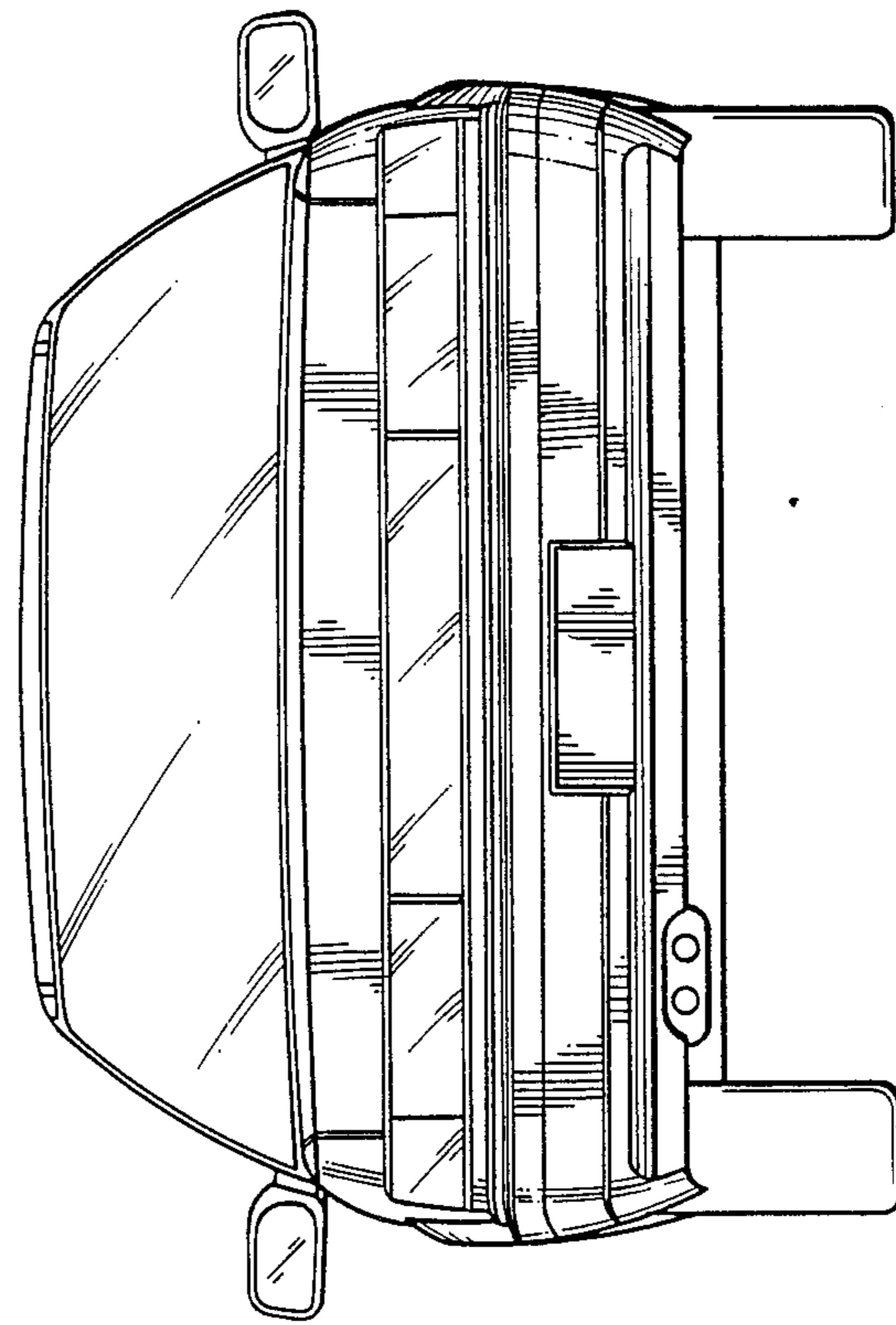

FIG. 4.

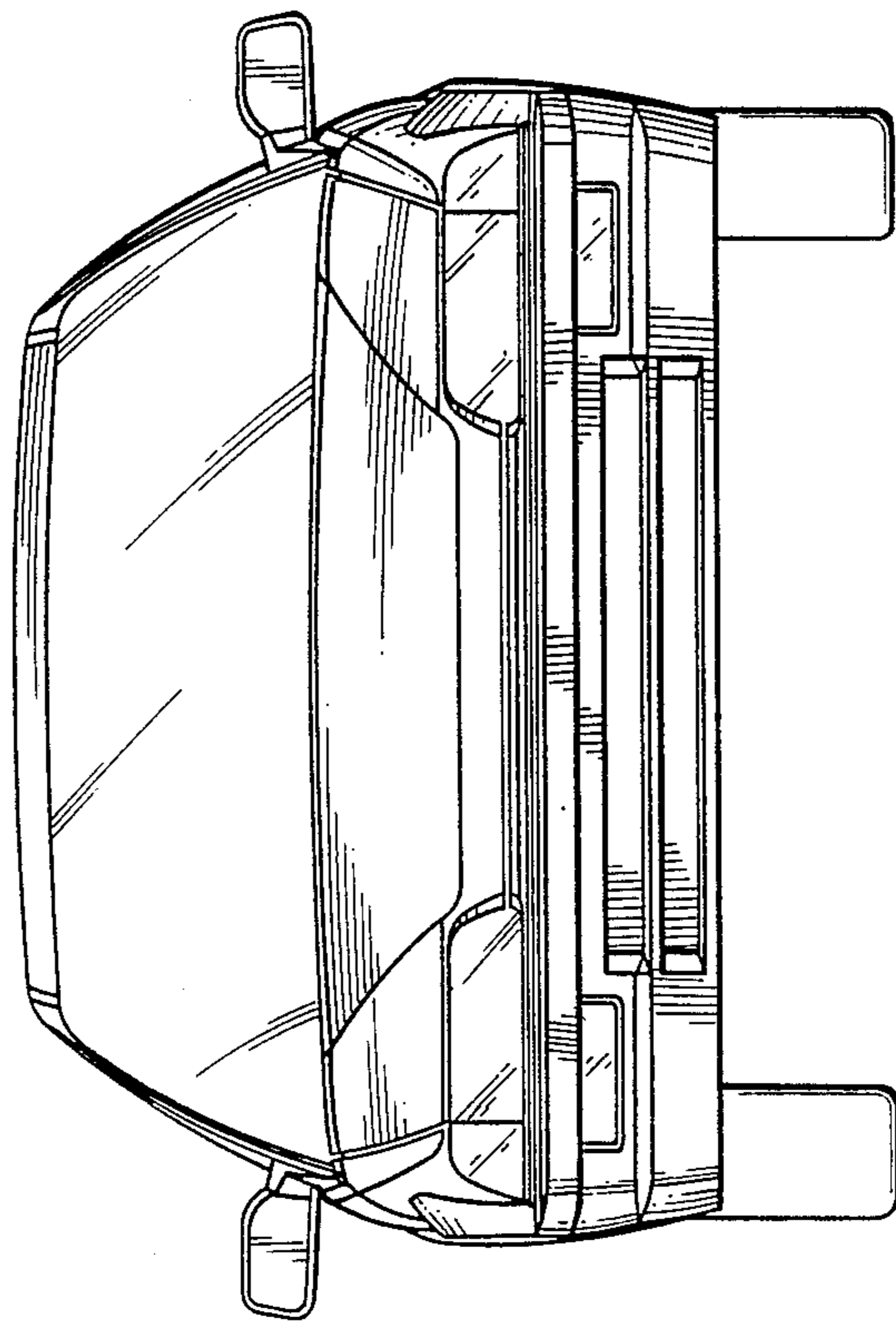

FIG. 3.

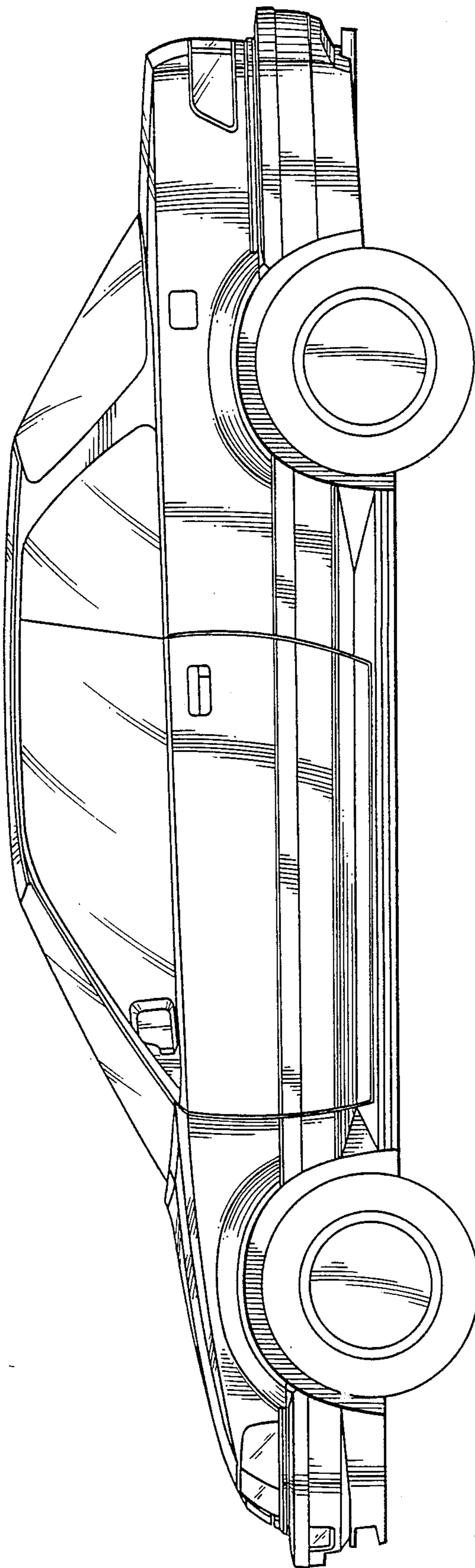

FIG. 5.