

[54] TRUCK FLOOR BED TIE-DOWN DEVICE

[76] Inventor: Marvin I. Nelson, 613 N. Washington, Dell Rapids, S. Dak. 57022

[\*\*] Term: 14 Years

[21] Appl. No.: 879,184

[22] Filed: Jun. 26, 1986

[52] U.S. Cl. .... D8/356; 248/499

[58] Field of Search ..... D8/356; D12/155; 248/499

[56] References Cited

U.S. PATENT DOCUMENTS

H000,256	4/1967	Annibale .....	248/499
D. 247,950	5/1978	Bottcher .....	D8/373 X
D. 291,058	7/1987	Sorenson .....	D8/356
2,936,992	5/1960	Browing .....	248/499
3,399,854	9/1968	Patterson .....	248/499
4,008,669	2/1977	Samrell .....	248/499 X
4,130,067	12/1978	Kilgus et al. ....	248/499 X
4,253,785	3/1981	Brontstein .....	D12/155
4,297,962	11/1981	Johnson et al. ....	248/499 X
4,762,449	8/1988	St. Pierre et al. ....	248/499 X

FOREIGN PATENT DOCUMENTS

837804	5/1972	Fed. Rep. of Germany .....	248/499
319696	1/1972	U.S.S.R. ....	248/499

Primary Examiner—Horace B. Fay, Jr.  
Attorney, Agent, or Firm—B. Craig Killough

[57] CLAIM

The ornamental design for a truck floor bed tie-down device as shown and described.

DESCRIPTION

FIG. 1 is a left side, top and front perspective view of a truck floor bed tie-down device showing my new design;

FIG. 2 is a left side elevational view thereof, the opposite side being a mirror image;

FIGS. 3 and 4 are respectively front and rear elevational views thereof;

FIGS. 5 and 6 are respectively top and bottom plan views thereof;

FIG. 7 is a side elevational view thereof in reposed position; and

FIG. 8 is a bracket-associated view thereof with the components spaced apart for clarity of illustration.

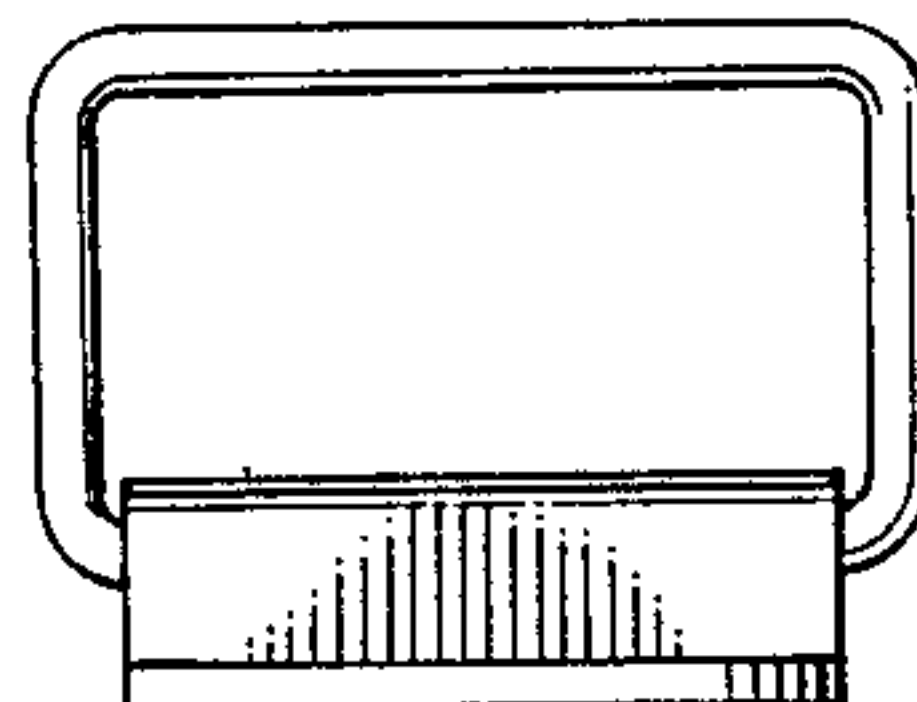
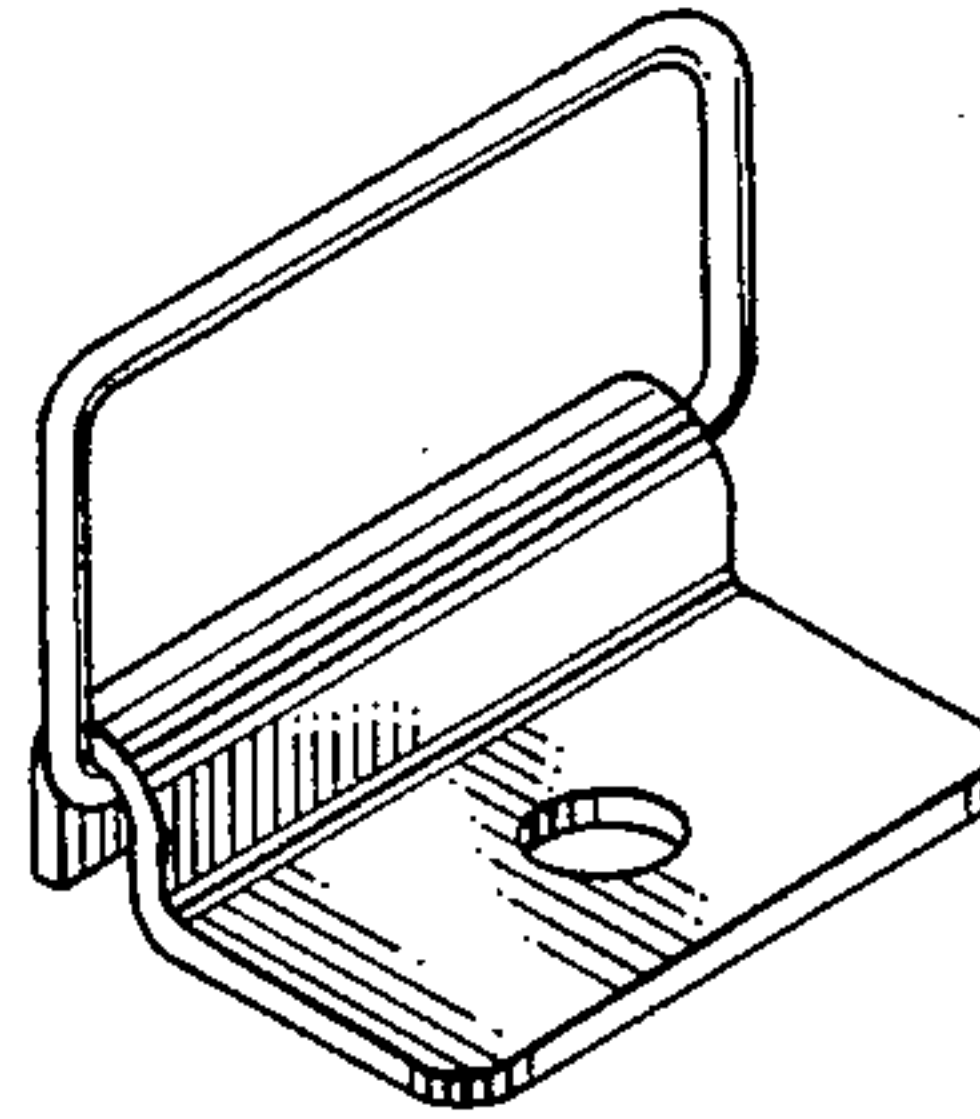

*FIG. 1.*

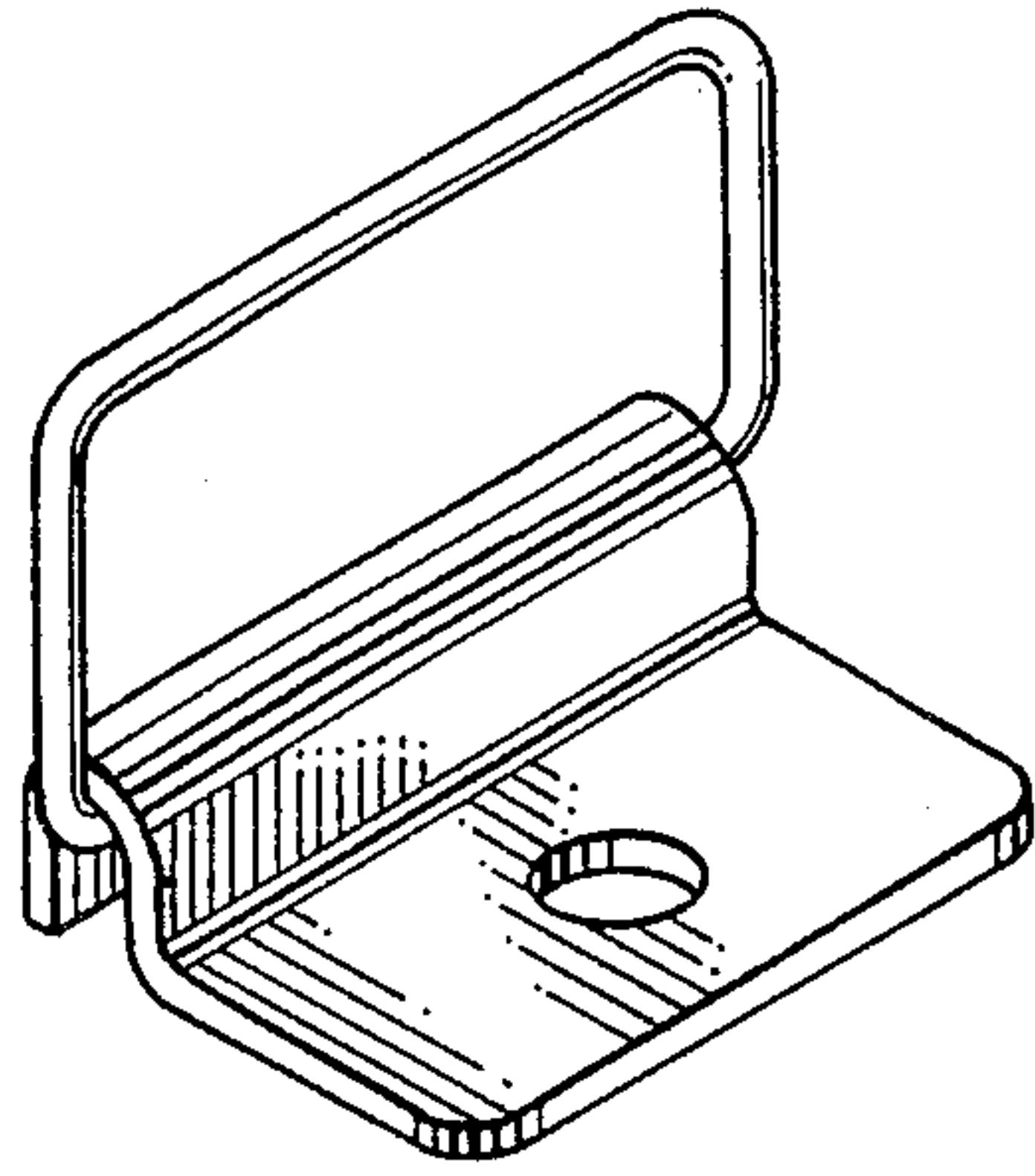

*FIG. 2.*

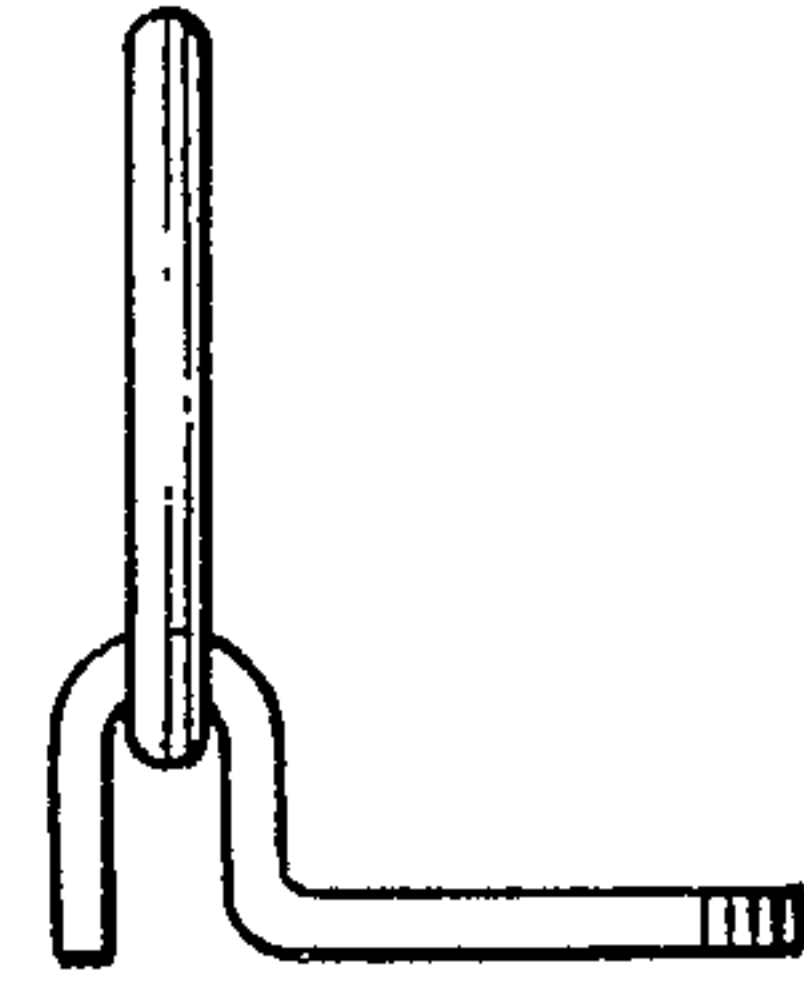

*FIG. 3.*

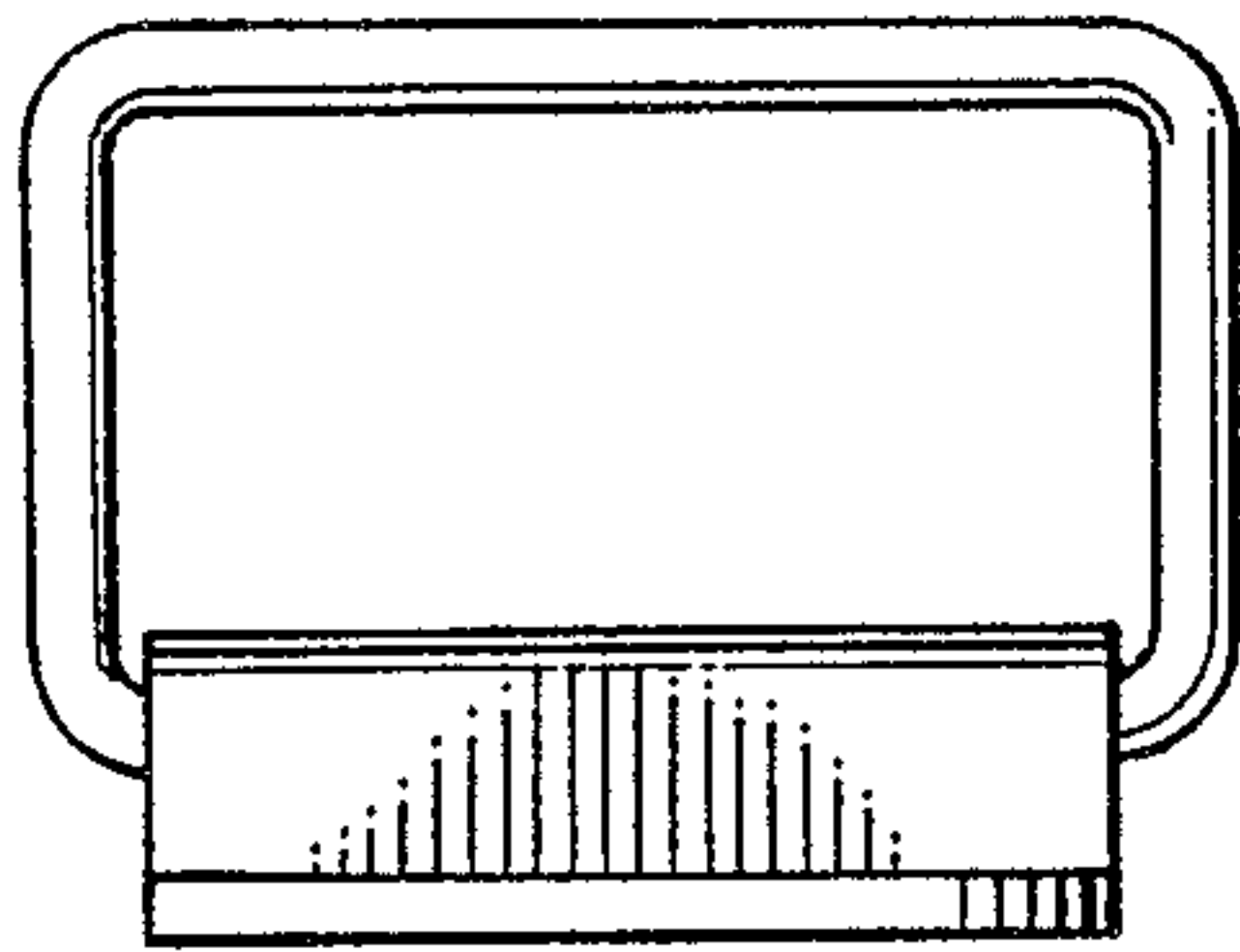

*FIG. 4.*

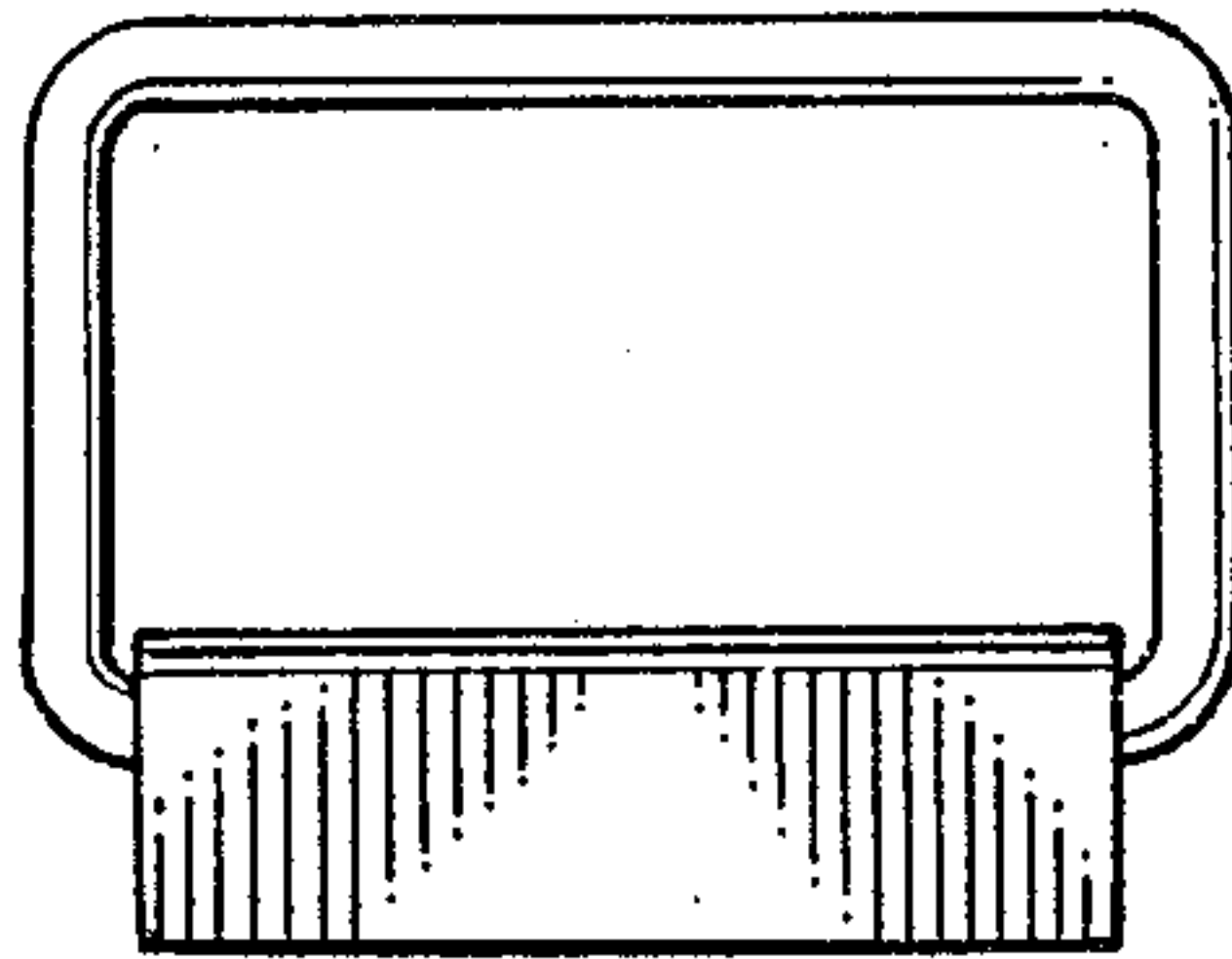

*FIG. 5.*

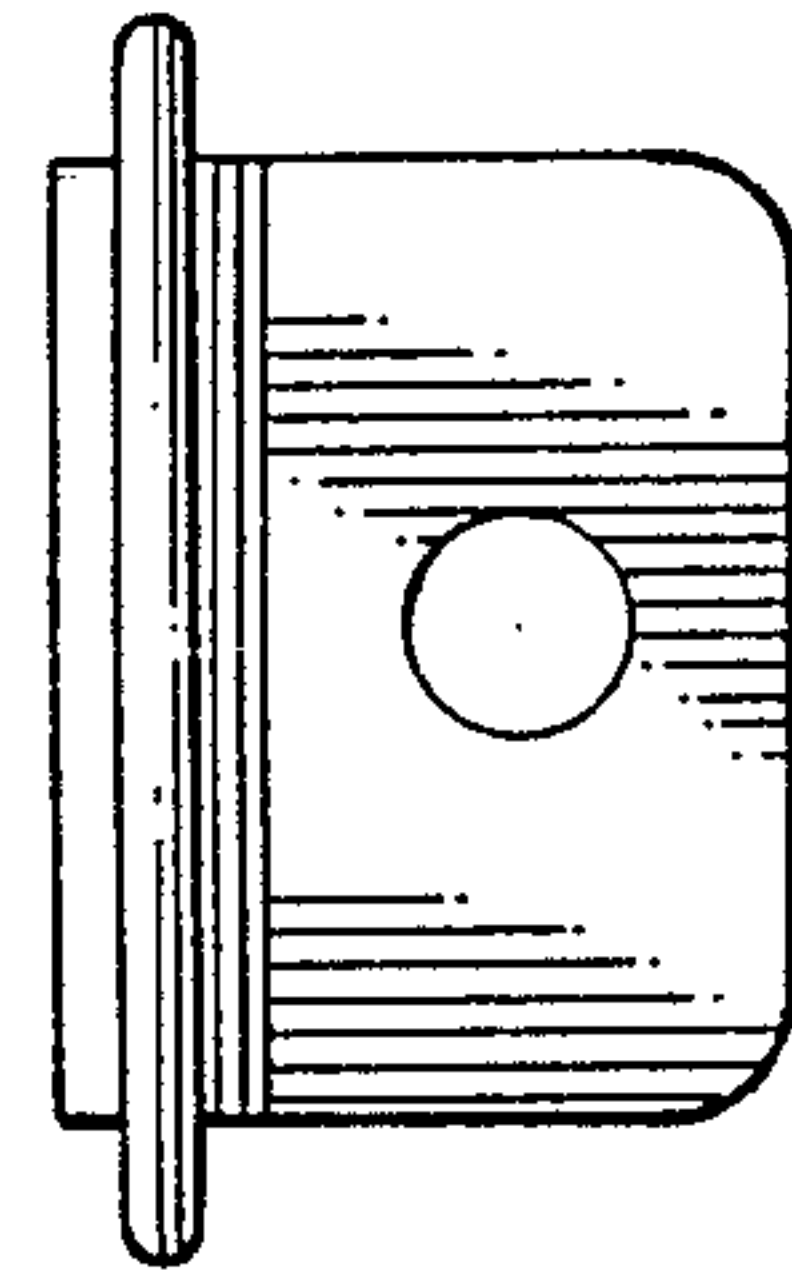

*FIG. 6.*

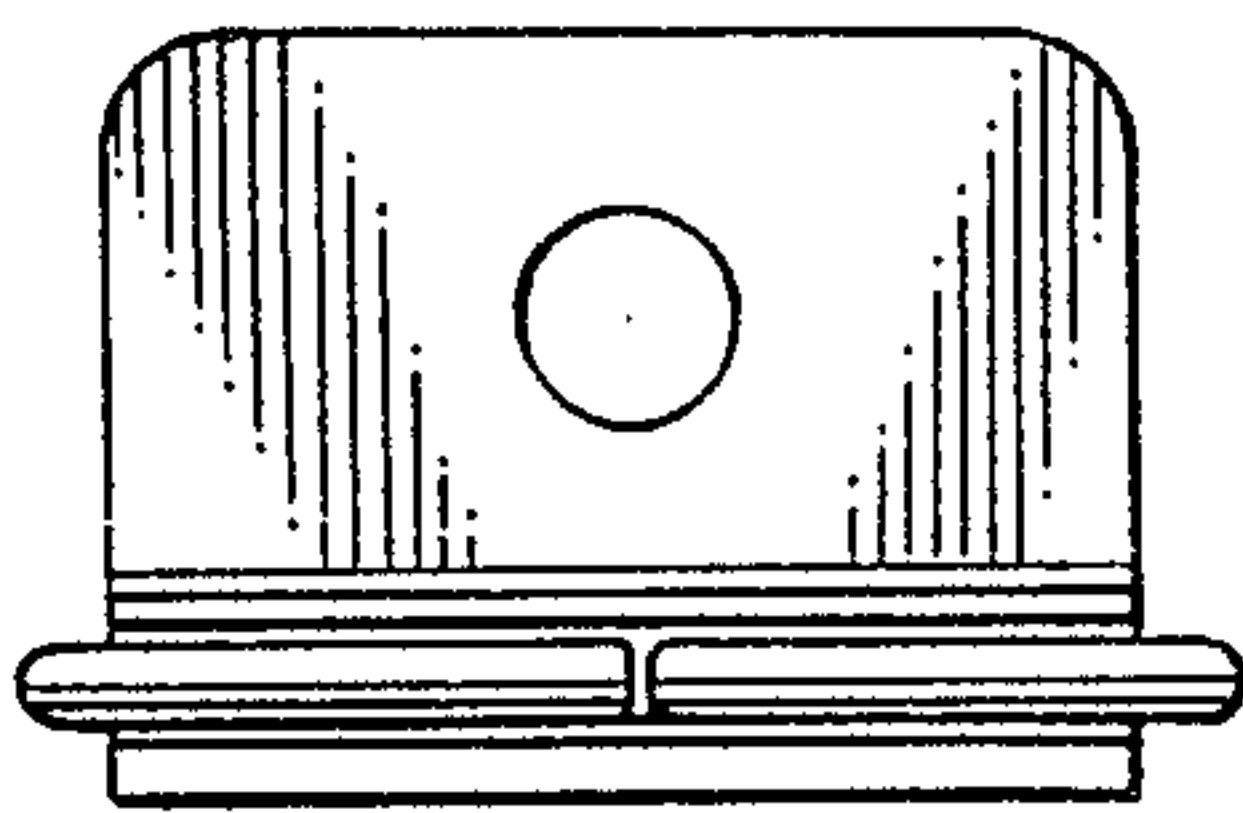

*FIG. 8.*

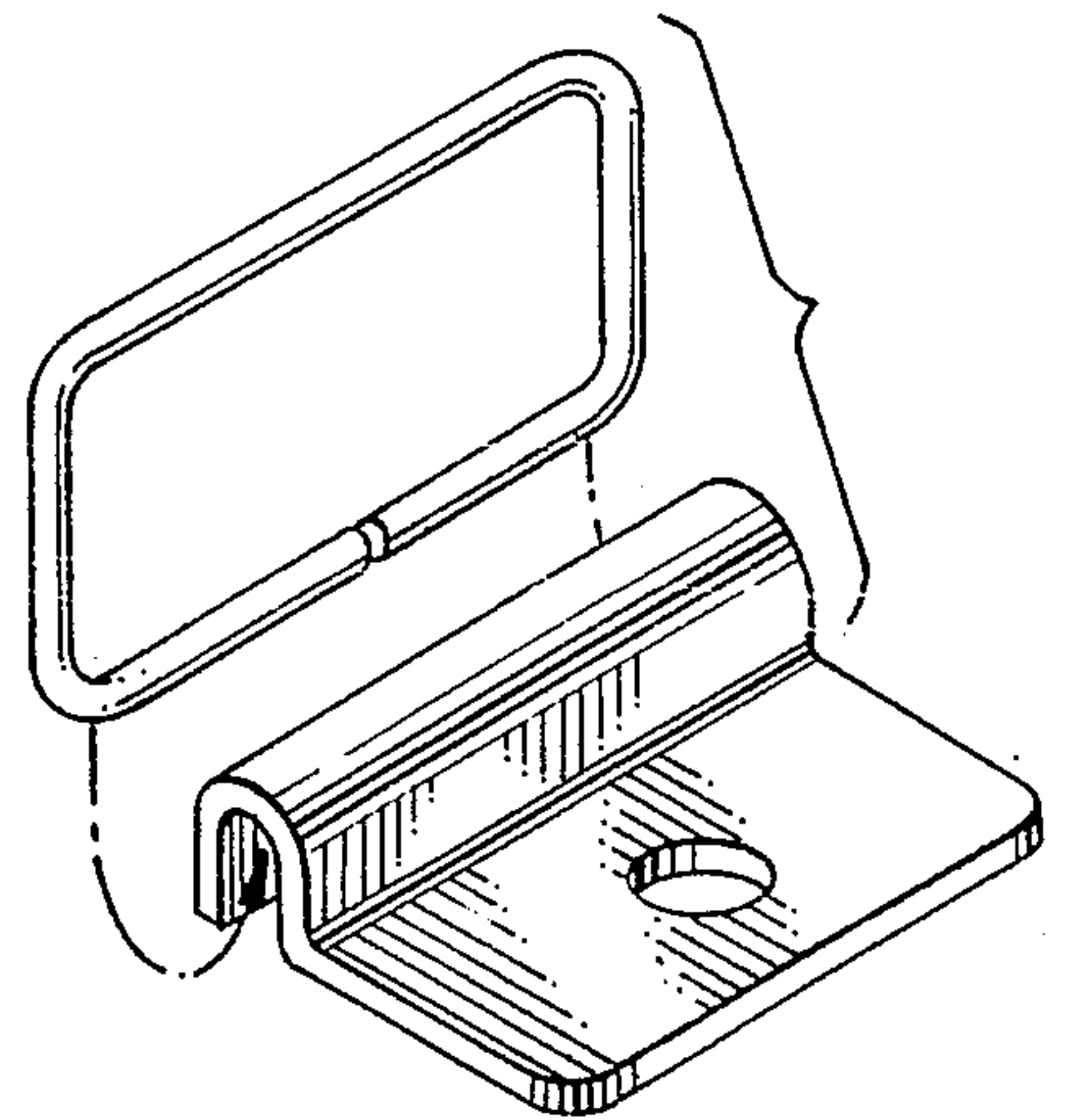

*FIG. 7.*

