

[54] CUTTING TOOL HOLDER

[76] Inventor: Wlajko Mihic, Tegnervägen 9, Gävle, S-802 28, Sweden

[**] Term: 14 Years

[21] Appl. No.: 888,312

[22] Filed: Jul. 21, 1986

[30] Foreign Application Priority Data

Jan. 29, 1986 [SE] Sweden 86-0222

[52] U.S. Cl. D15/140

[58] Field of Search D8/71, 98; D15/138, D15/139, 140

[56] References Cited

U.S. PATENT DOCUMENTS

D. 220,921 6/1971 Cochran D15/139
4,340,325 7/1982 Gowanlock D15/139 X

OTHER PUBLICATIONS

Morse Cutting Tools Division brochure, 2 pages, 1/23/1978, Carbide Cutting Tools.

Kennametal/81 Catalog, Metal Cutting Tools, ©1980, p. 83, "Deep Grooving KGC Tool Holder".

Carboly Systems Carb-O-Lock Toolholders, Boring Bars & Cartridges Catalog, 10/30/1984, p. 57, top panel, style LBR (inset panel, top right corner).

Carboly Systems Carb-O-Lock Toolholders, Boring Bars & Cartridges, 10/30/1984, p. 41, both figures, styles B triangle, B square.

Primary Examiner—Winifred E. Herrmann

Assistant Examiner—John Warchol

Attorney, Agent, or Firm—Beveridge, DeGrandi & Weilacher

[57] CLAIM

The ornamental design for a cutting tool holder, as shown and described.

DESCRIPTION

FIG. 1 is a top, front, and right side perspective view of a cutting tool holder showing my new design;

FIG. 2 is a top, front, and left side perspective view thereof;

FIG. 3 is a bottom, front, and left side perspective view thereof.

The rear end view is flat and unornamented.

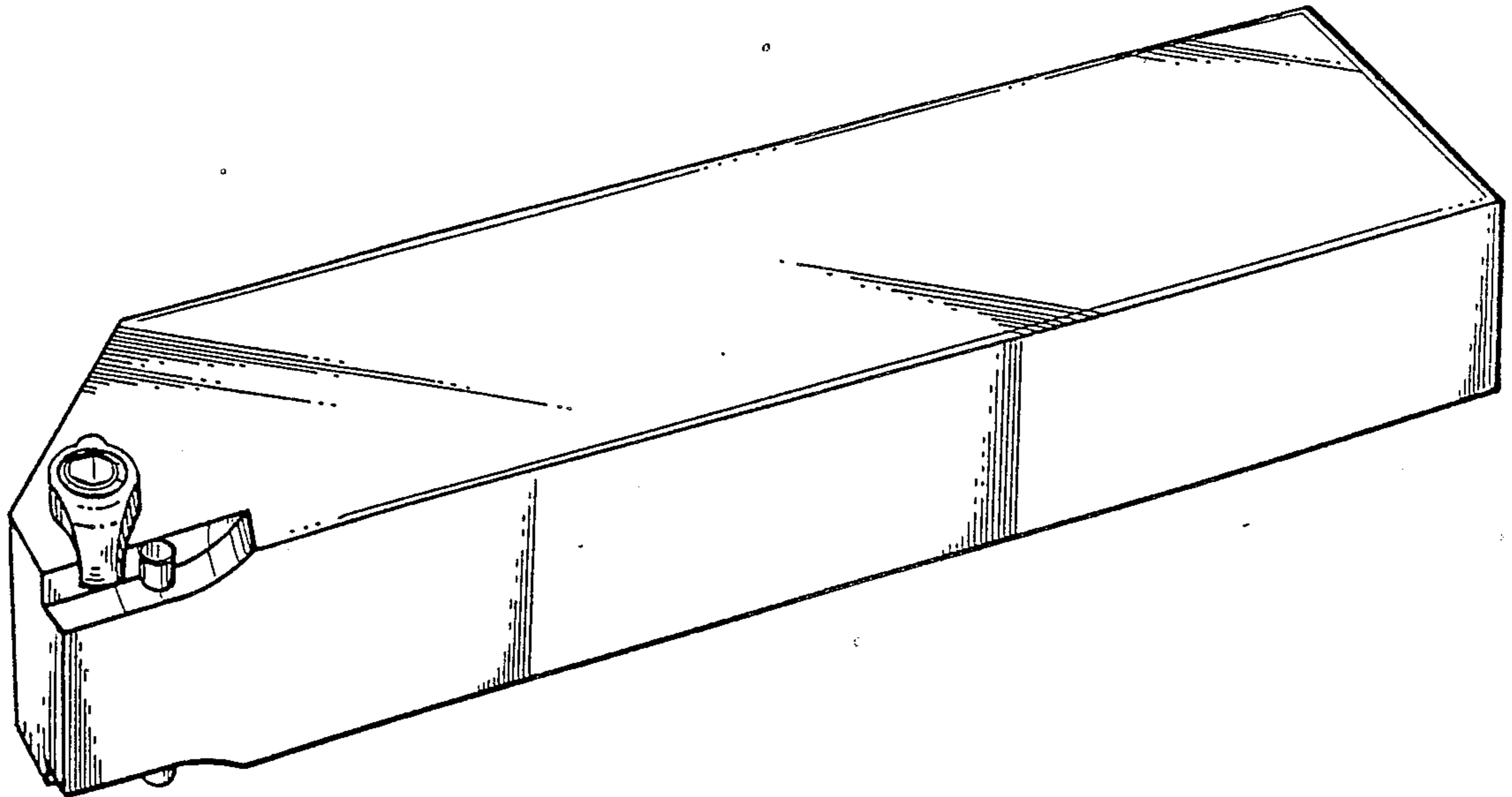

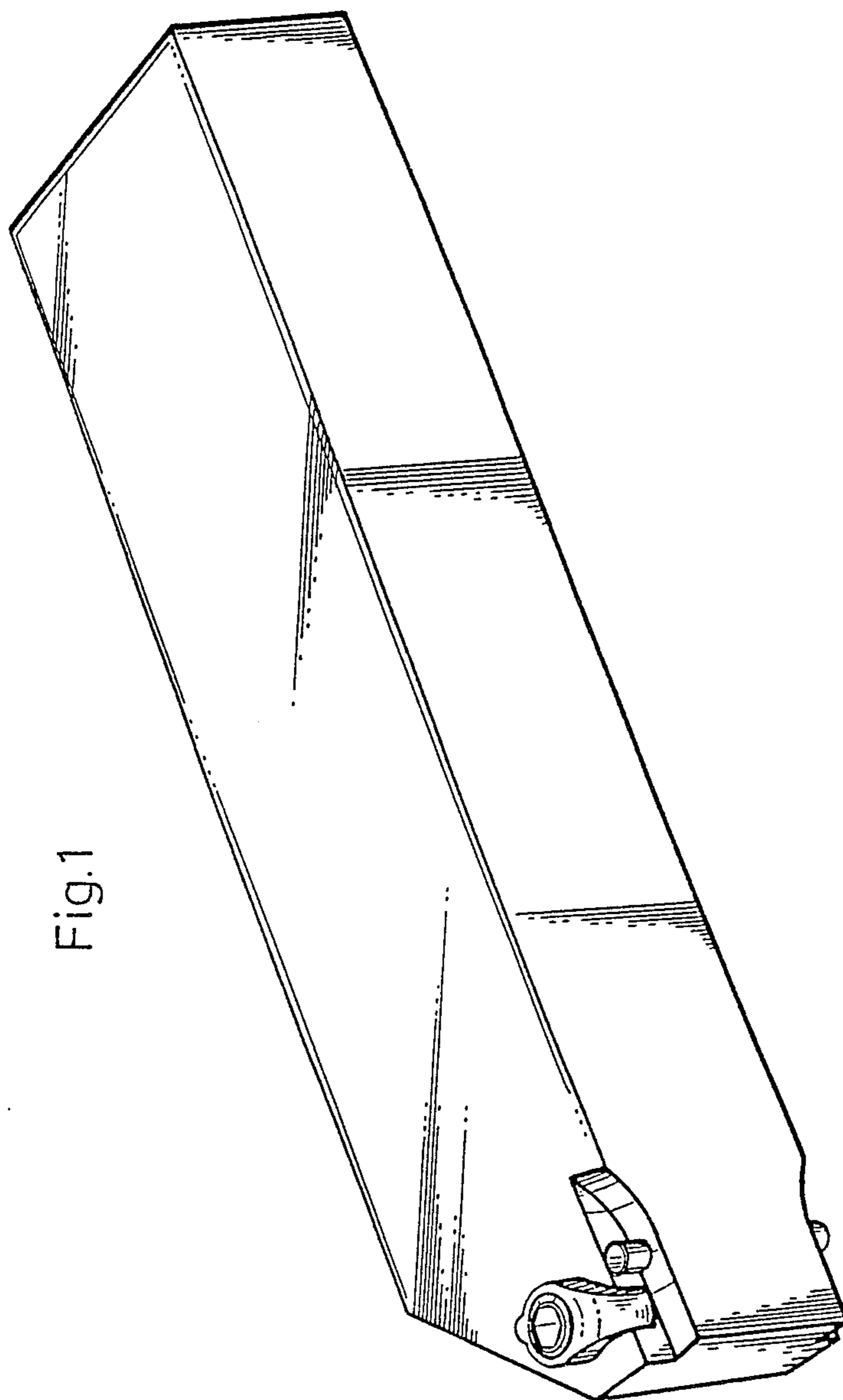

Fig.1

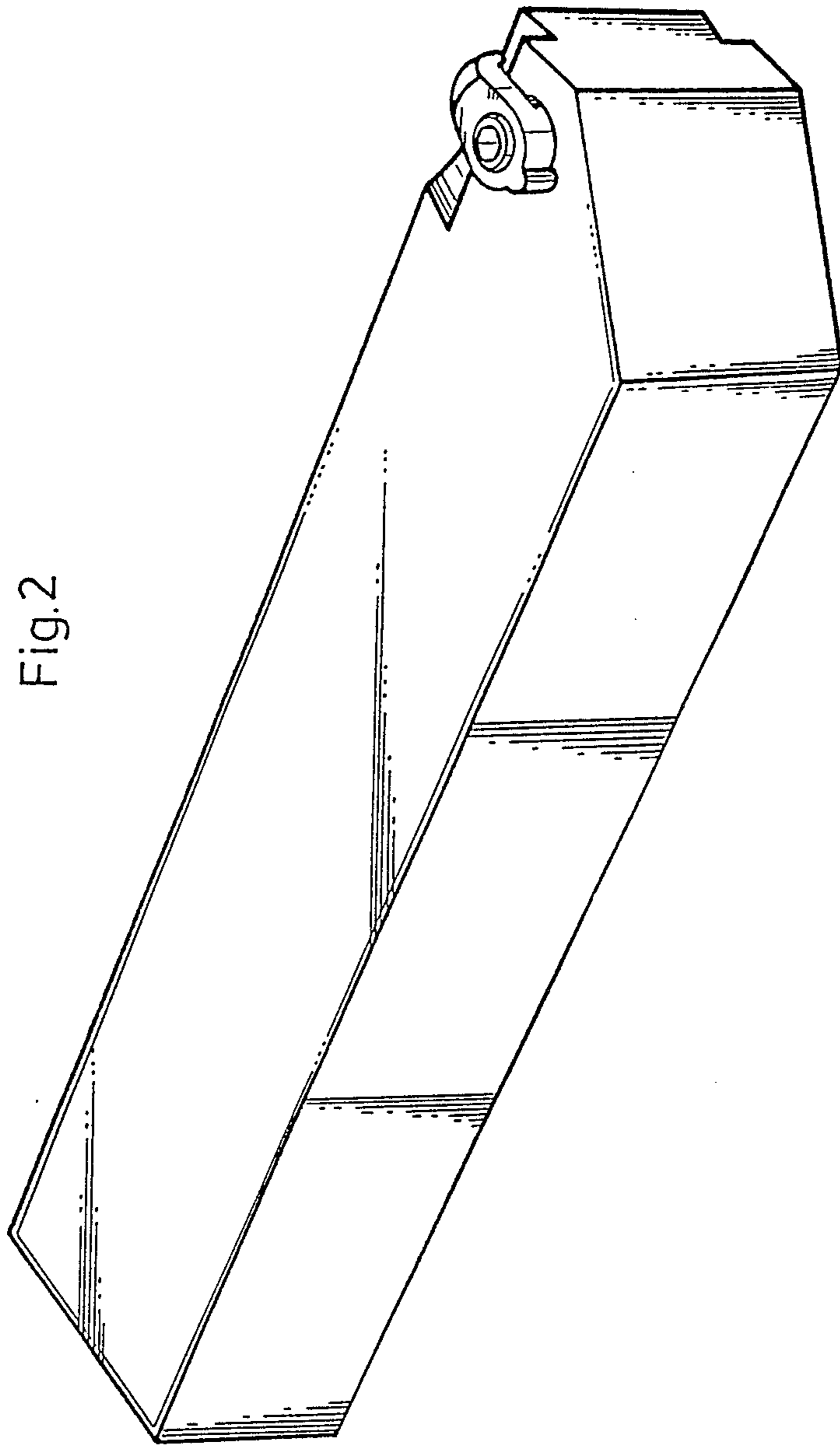

Fig.2

Fig. 3

