

[54] AUTOMOBILE

[75] Inventors: Koichi Hirata; Kozo Kikuchi, all of Saitama, Japan

[73] Assignee: Honda Giken Kogyo Kabushiki Kaisha, Tokyo, Japan

[**] Term: 14 Years

[21] Appl. No.: 36,568

[22] Filed: Apr. 9, 1987

[30] Foreign Application Priority Data

Oct. 9, 1986 [JP] Japan 61-40128

[52] U.S. Cl. D12/91

[58] Field of Search D12/91, 92; 296/185

[56] References Cited

U.S. PATENT DOCUMENTS

D. 282,058 1/1986 Tanaka et al. D12/91

OTHER PUBLICATIONS

Motor Trend, 7/86, p. 48, Honda Civic Wagon. 1985 Conquest, Colt & Vista Catalog, p. 33, Colt Vista Wagon.

Motor Trend, 11/85, p. 47, Honda Accord, bottom right side of page.

Motor Trend, 7/86, p. 47, Nissan Stanza Wagon.

Primary Examiner—James M. Gandy
Attorney, Agent, or Firm—Lyon & Lyon

[57] CLAIM

The ornamental design of an automobile, as shown.

DESCRIPTION

FIG. 1 is a right side elevation view of an automobile showing the new design;

FIG. 2 is a left side elevation view thereof;

FIG. 3 is a front elevation view thereof;

FIG. 4 is a rear elevation view thereof; and

FIG. 5 is a top plan view thereof.

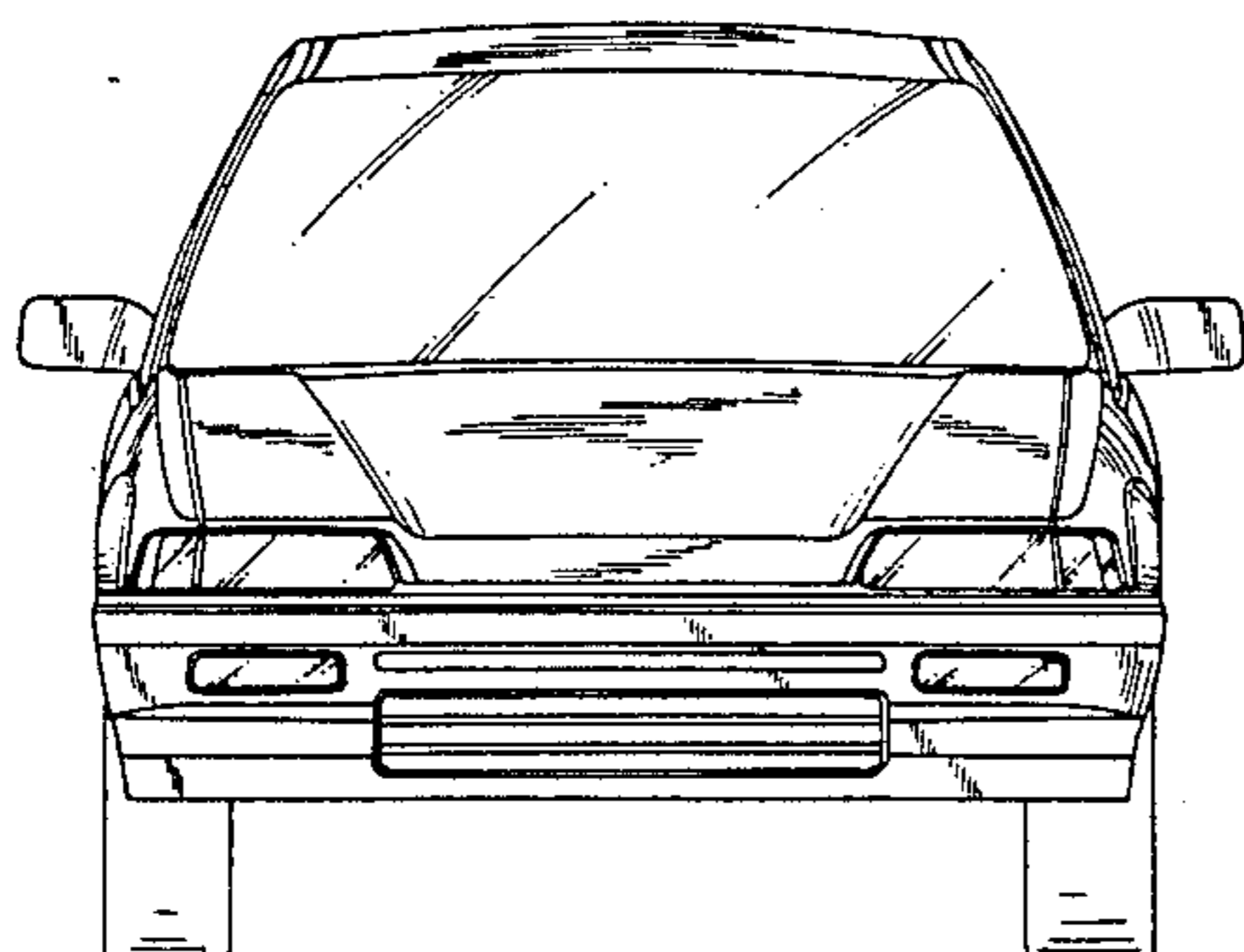
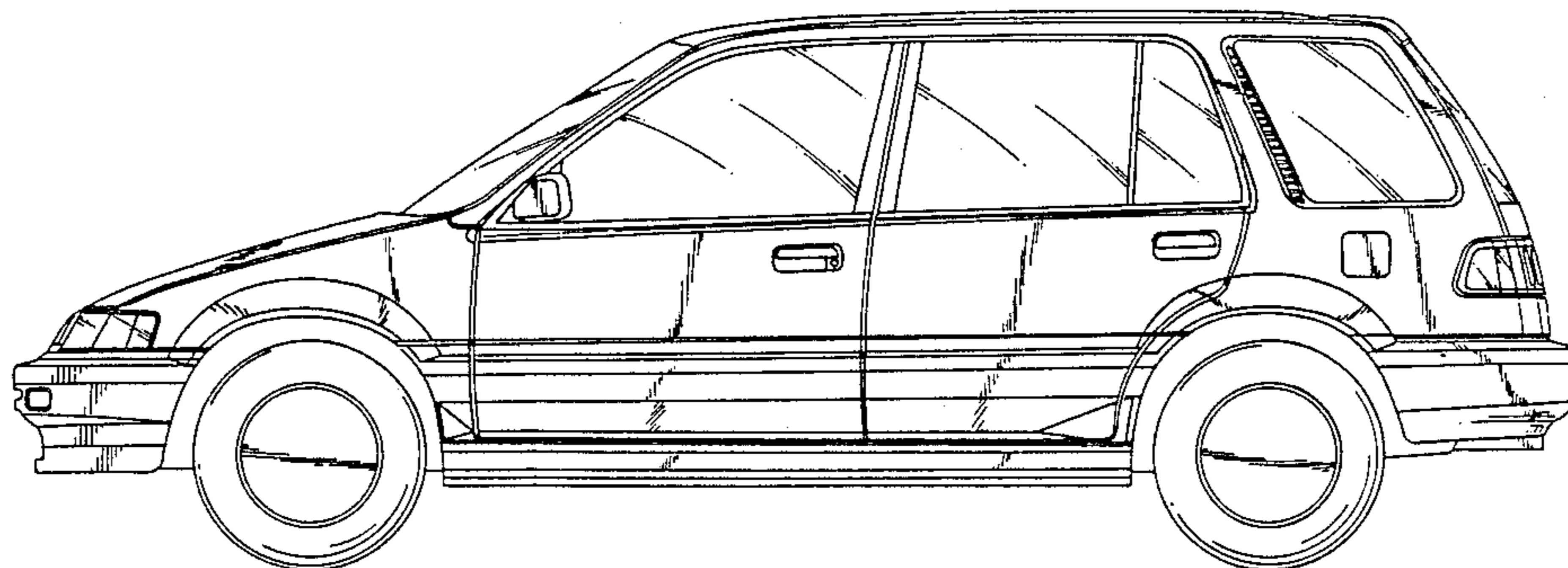

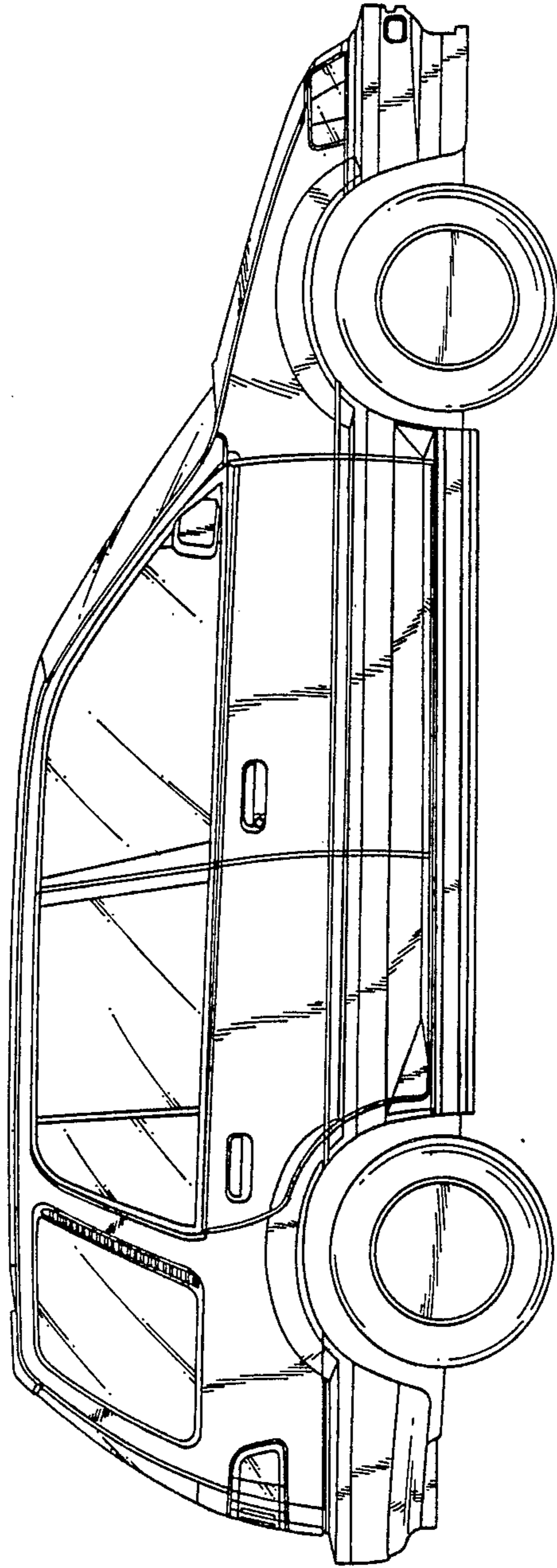

Fig. 1.

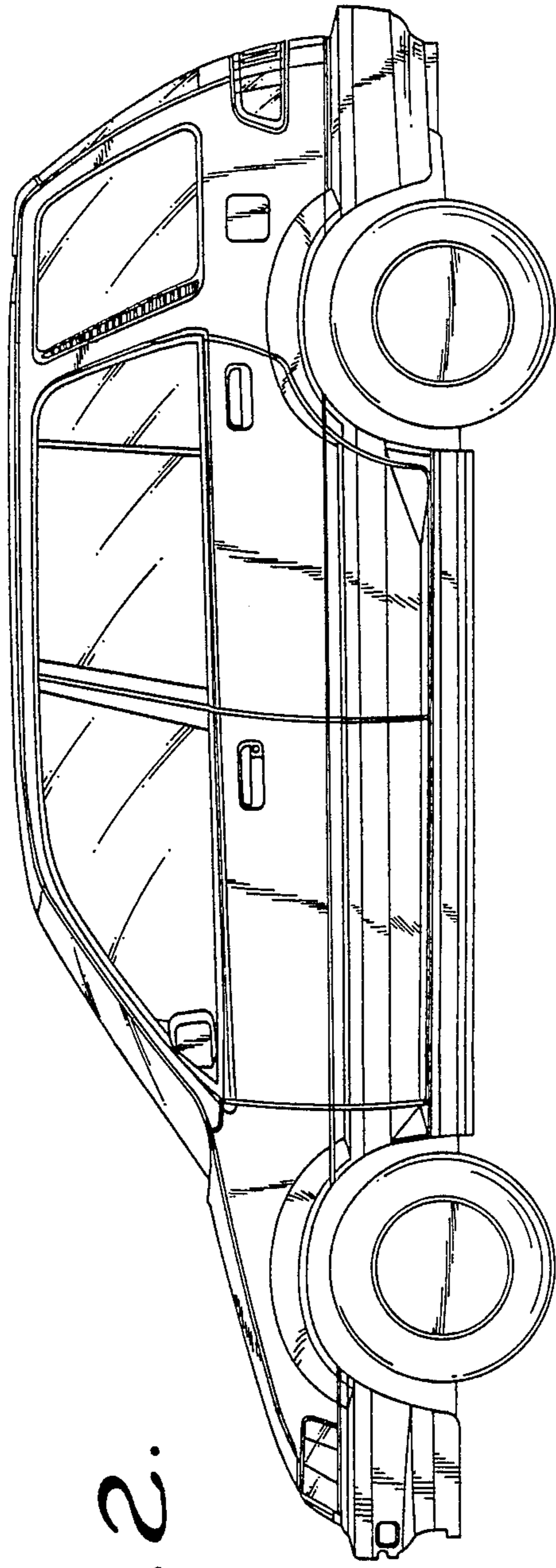

FIG. 2.

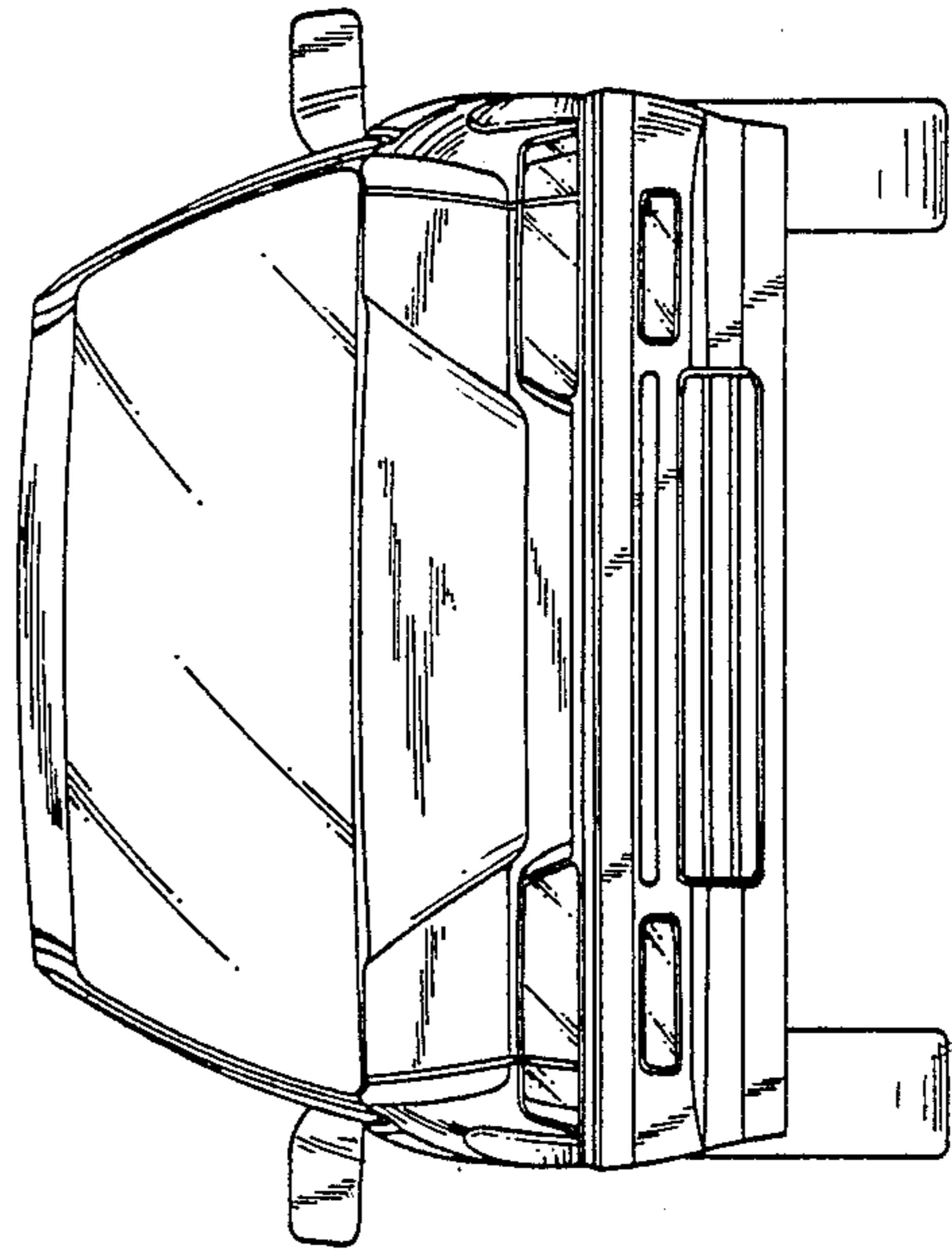

FIG. 3.

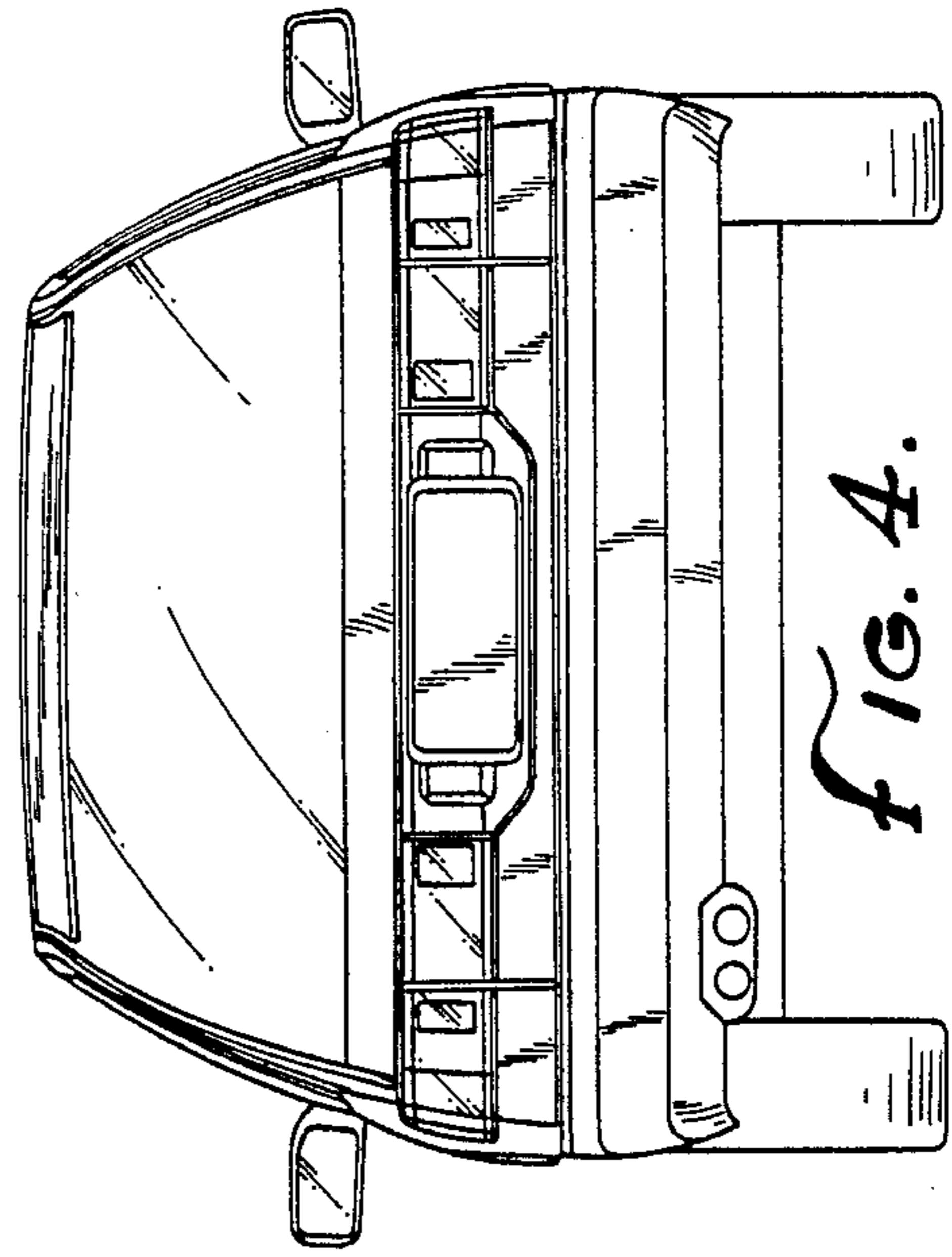

FIG. 4.

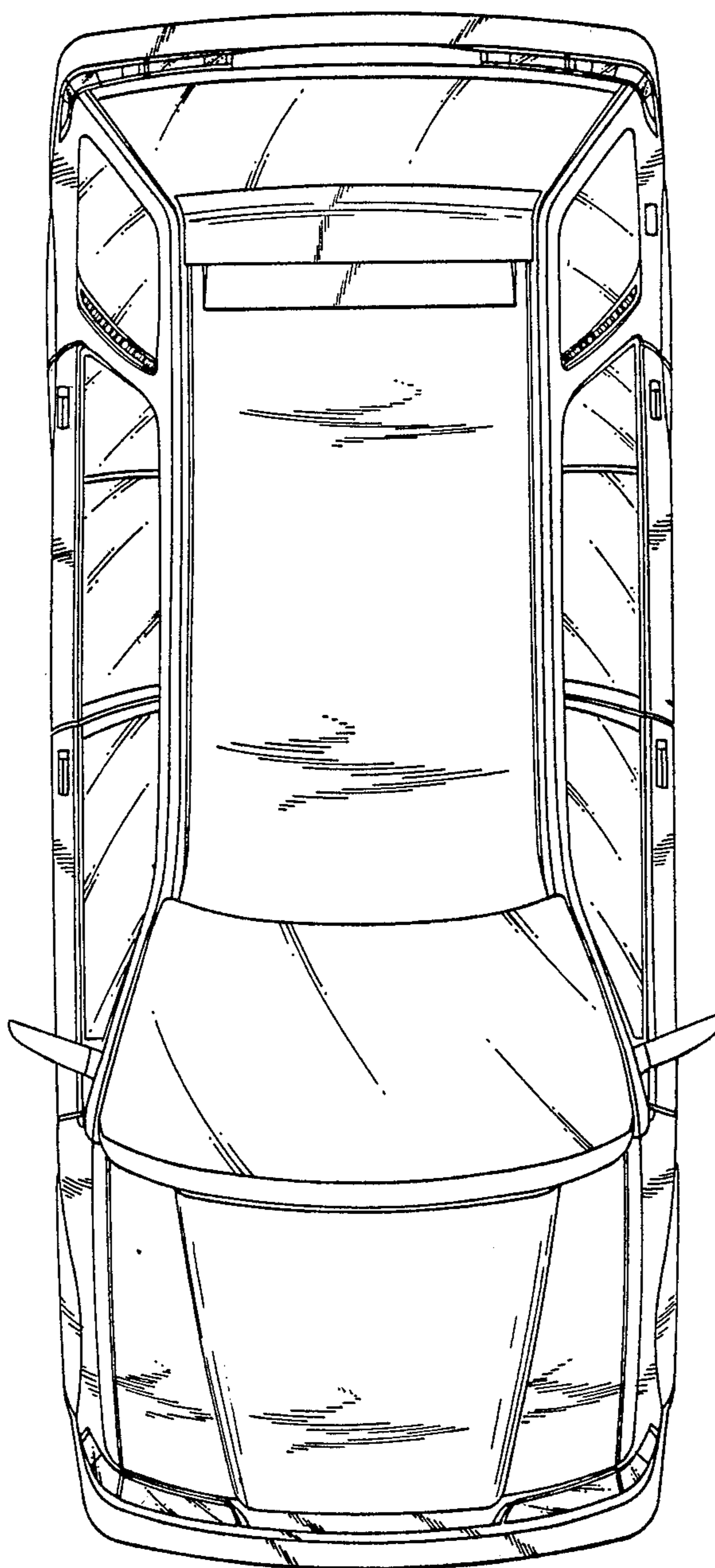

fig. 5.