

[54] **TRANSIT**

[75] **Inventor: Mikio Hayashi, Tokyo, Japan**

[73] **Assignees: World Surveying Instrument Co., Ltd.; Berger Instruments, both of Japan**

[**] **Term: 14 Years**

[21] **Appl. No.: 59,466**

[22] **Filed: Jun. 8, 1987**

[52] **U.S. Cl. D10/66**

[58] **Field of Search D10/62, 65, 66, 103; 33/290, 291, 292, 293, 294, 295, 296, 297, 298, 299; 356/138, 139, 140, 141, 142, 143, 144, 145, 146, 147, 148, 149, 150, 151, 152, 153, 154, 155**

[56] **References Cited**

U.S. PATENT DOCUMENTS

- D. 98,678 2/1936 Langsner D10/74
- D. 250,400 11/1978 Haidek D10/103
- 2,774,275 12/1956 Keller 356/138

OTHER PUBLICATIONS

Eugene Dietzgen Co., Various Transits, 1946, pp. 520-574.

Gurley, Engineering News Record, 7/10/1947, cover page.

The K&E Paragon Transit, 1959, cover pages.

Keuffel & Esser Company, Surveying Instruments, 1962, pp. 19-38.

Primary Examiner—Nelson C. Holtje

Assistant Examiner—Antoine D. Davis

Attorney, Agent, or Firm—Eric P. Schellin

[57] **CLAIM**

The new design for a transit, as shown.

DESCRIPTION

FIG. 1 is a top, front, and left side perspective view of a transit showing my new design;

FIG. 2 is a front elevational view;

FIG. 3 is a right side elevational view;

FIG. 4 is a left side elevational view;

FIG. 5 is a rear elevational view;

FIG. 6 is a top plan view; and

FIG. 7 is a bottom plan view thereof, FIGS. 1-7 are shown with a lens cover thereon.

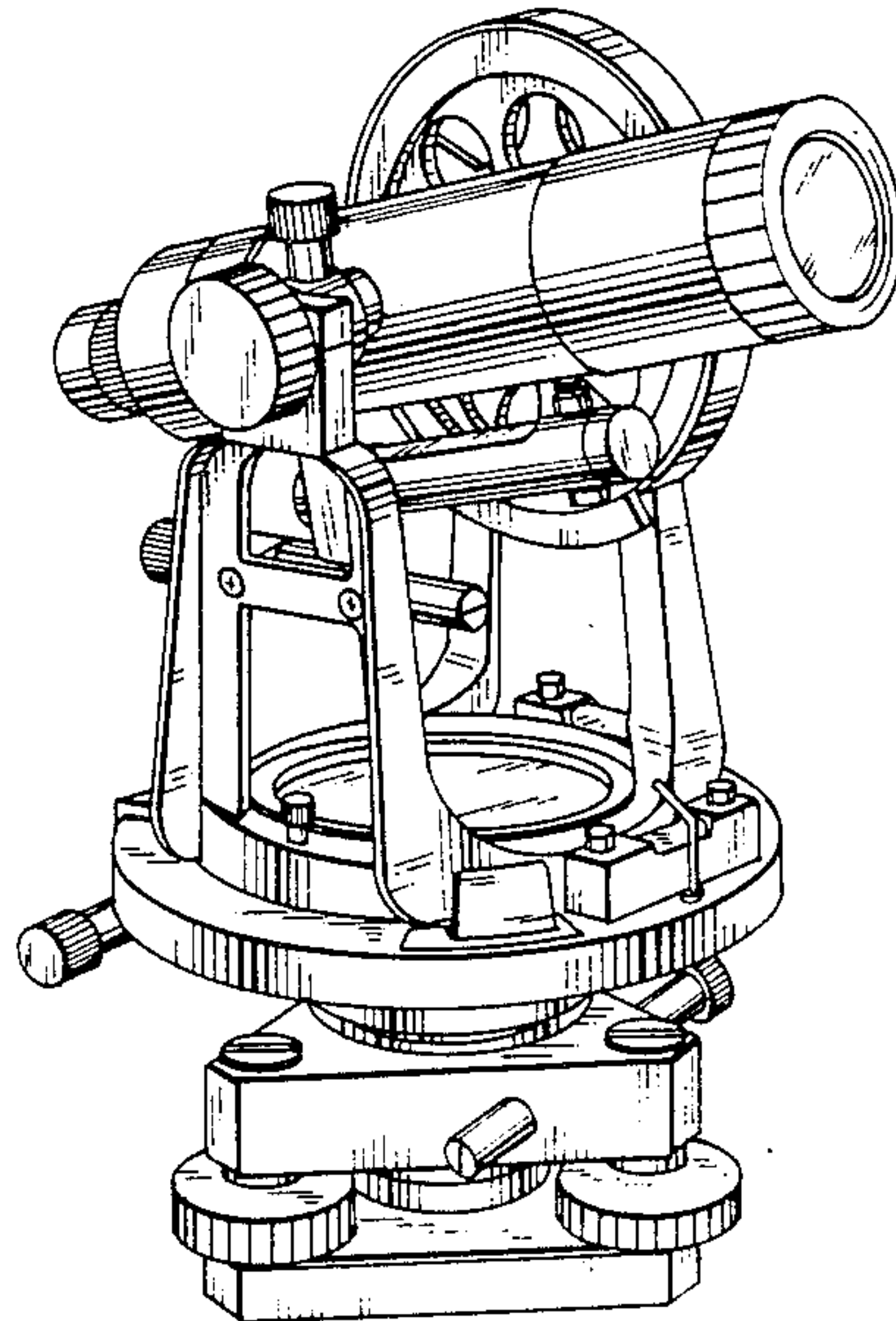

FIG. 1

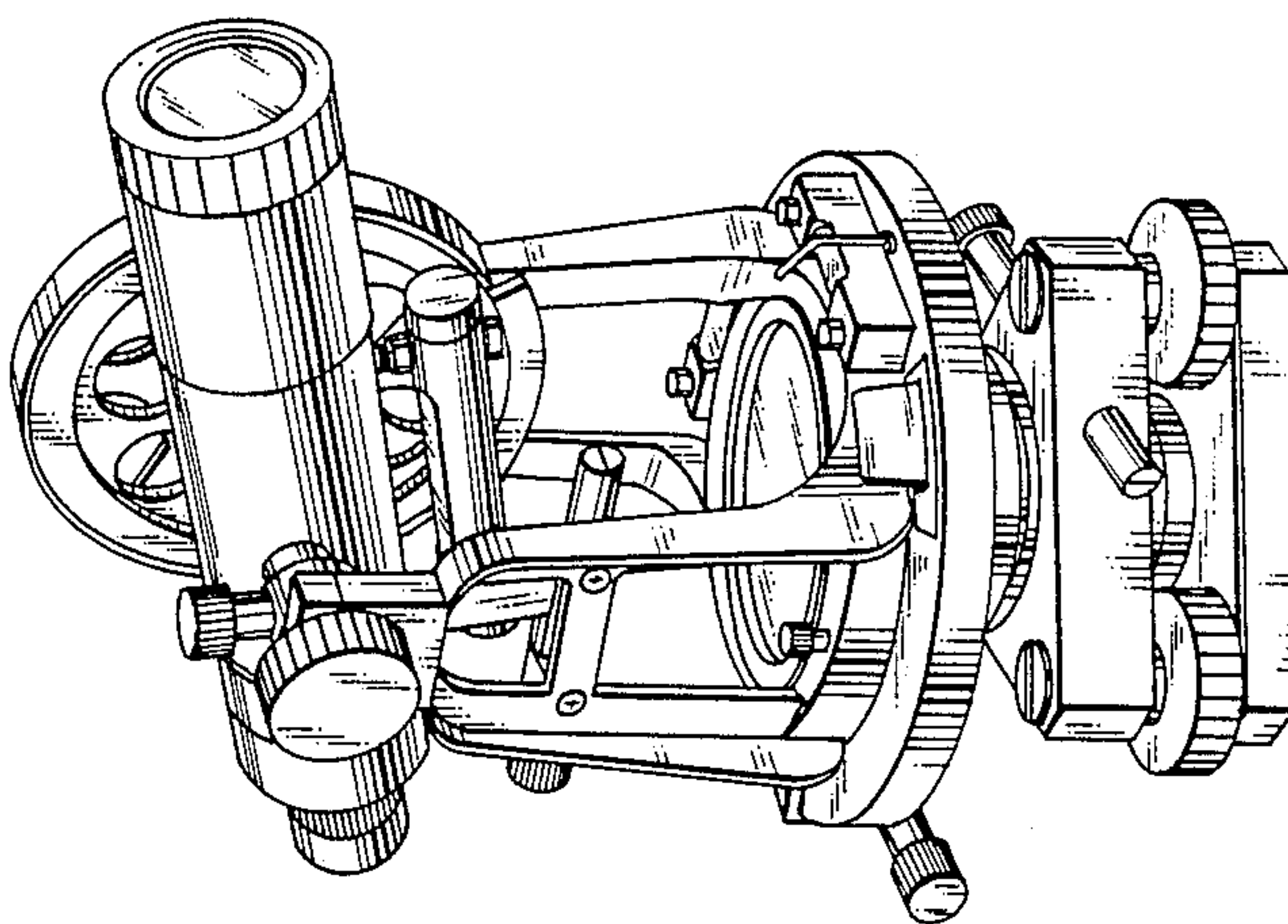

FIG. 3

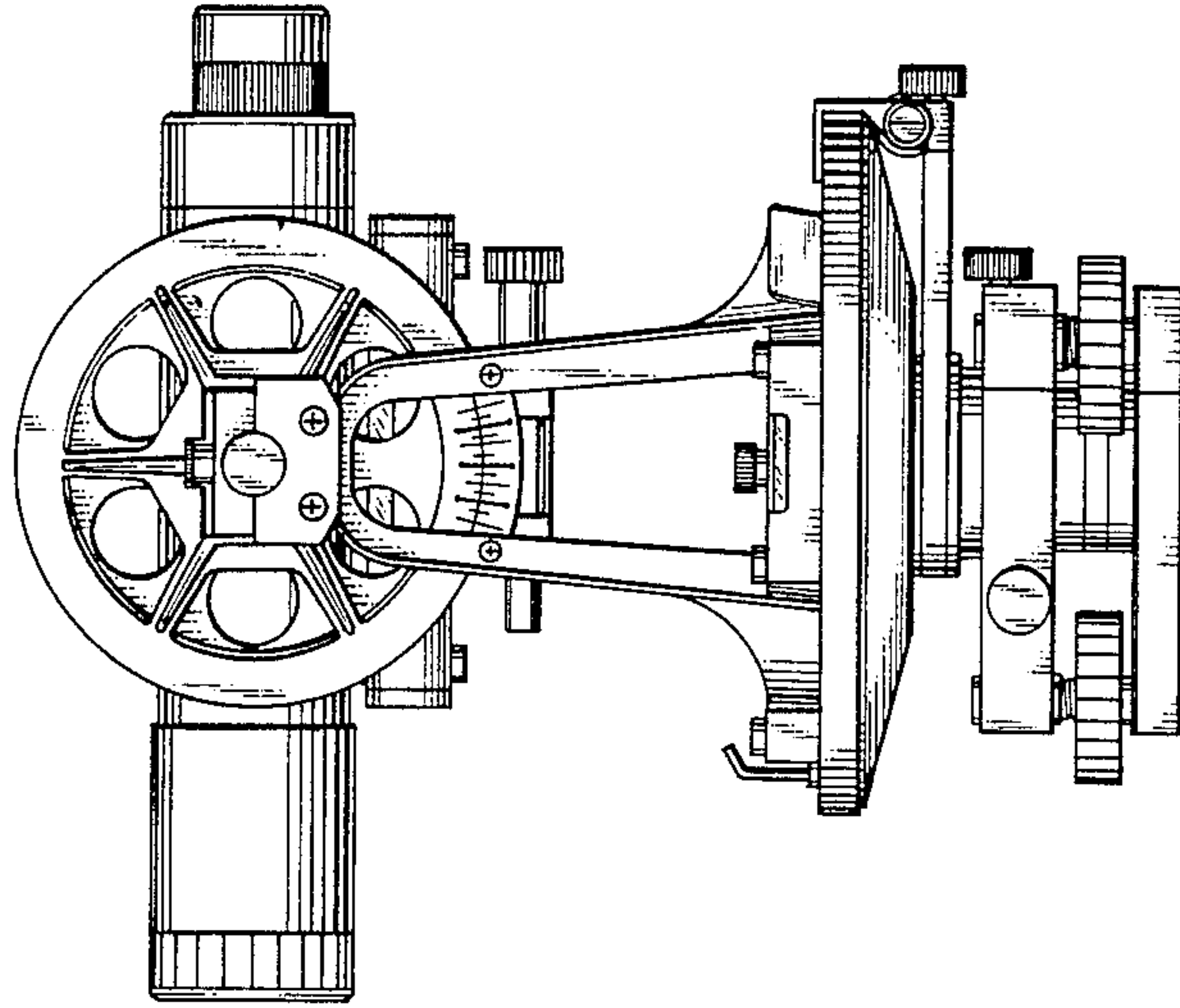

FIG. 2

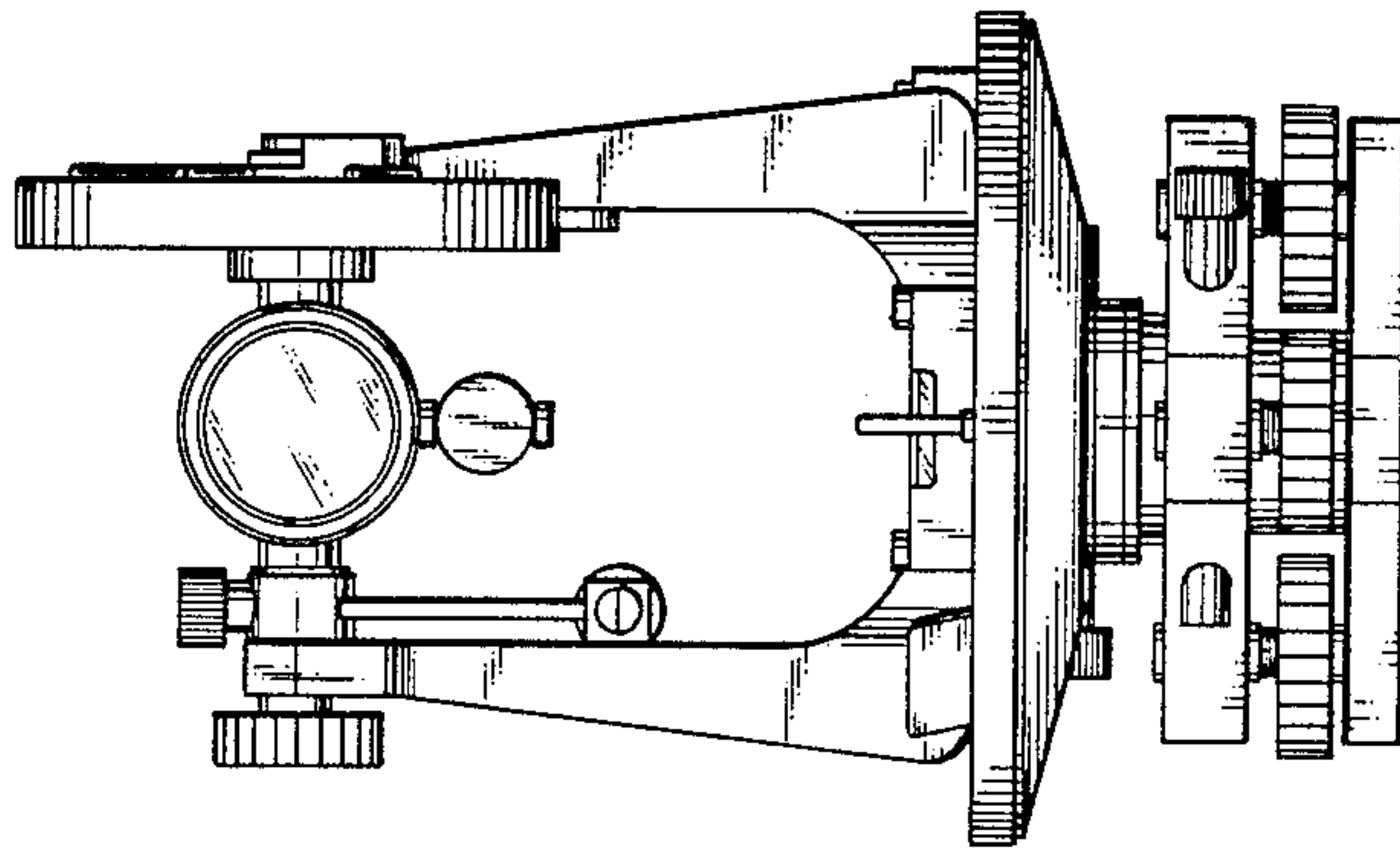

FIG. 5

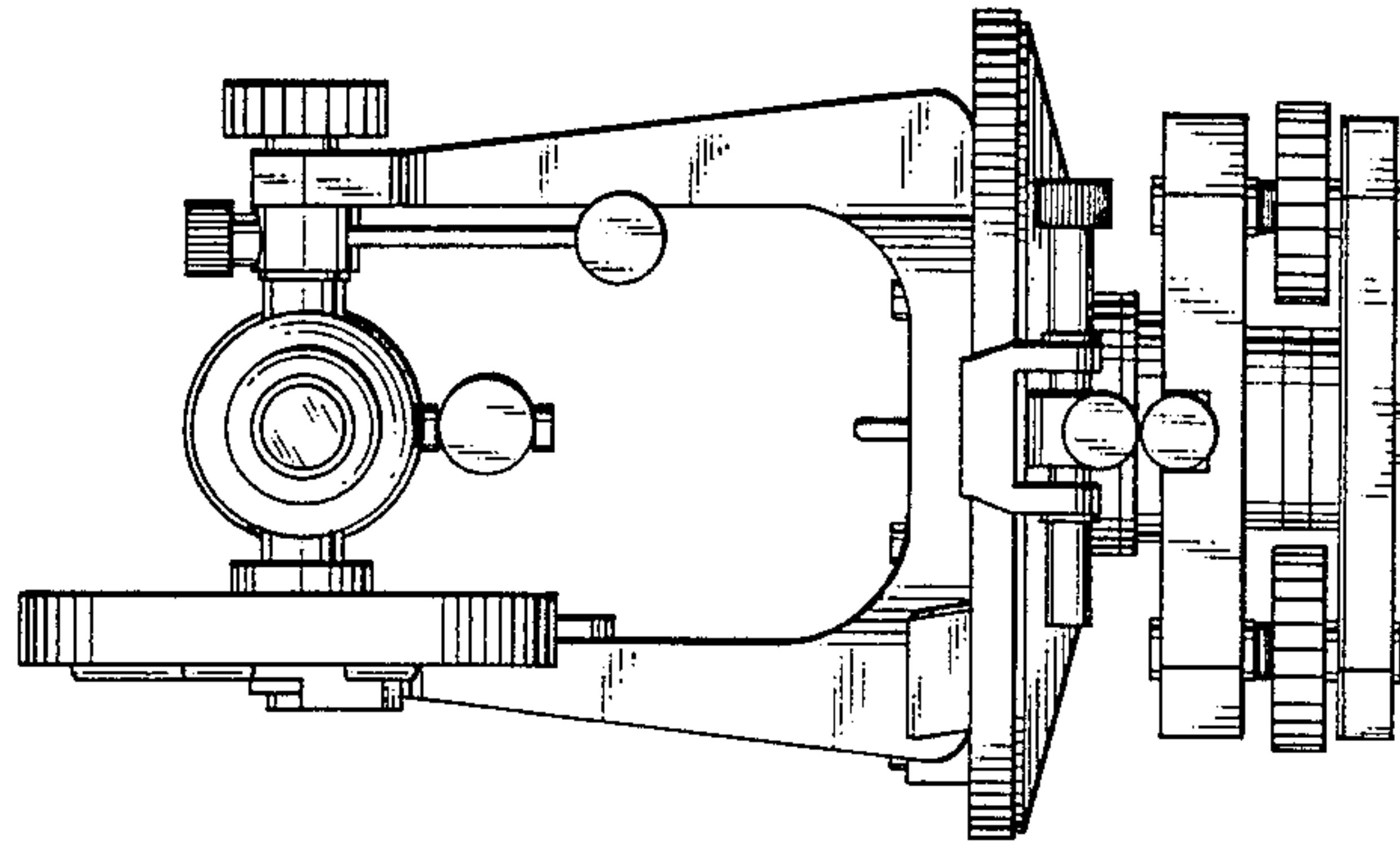

FIG. 4

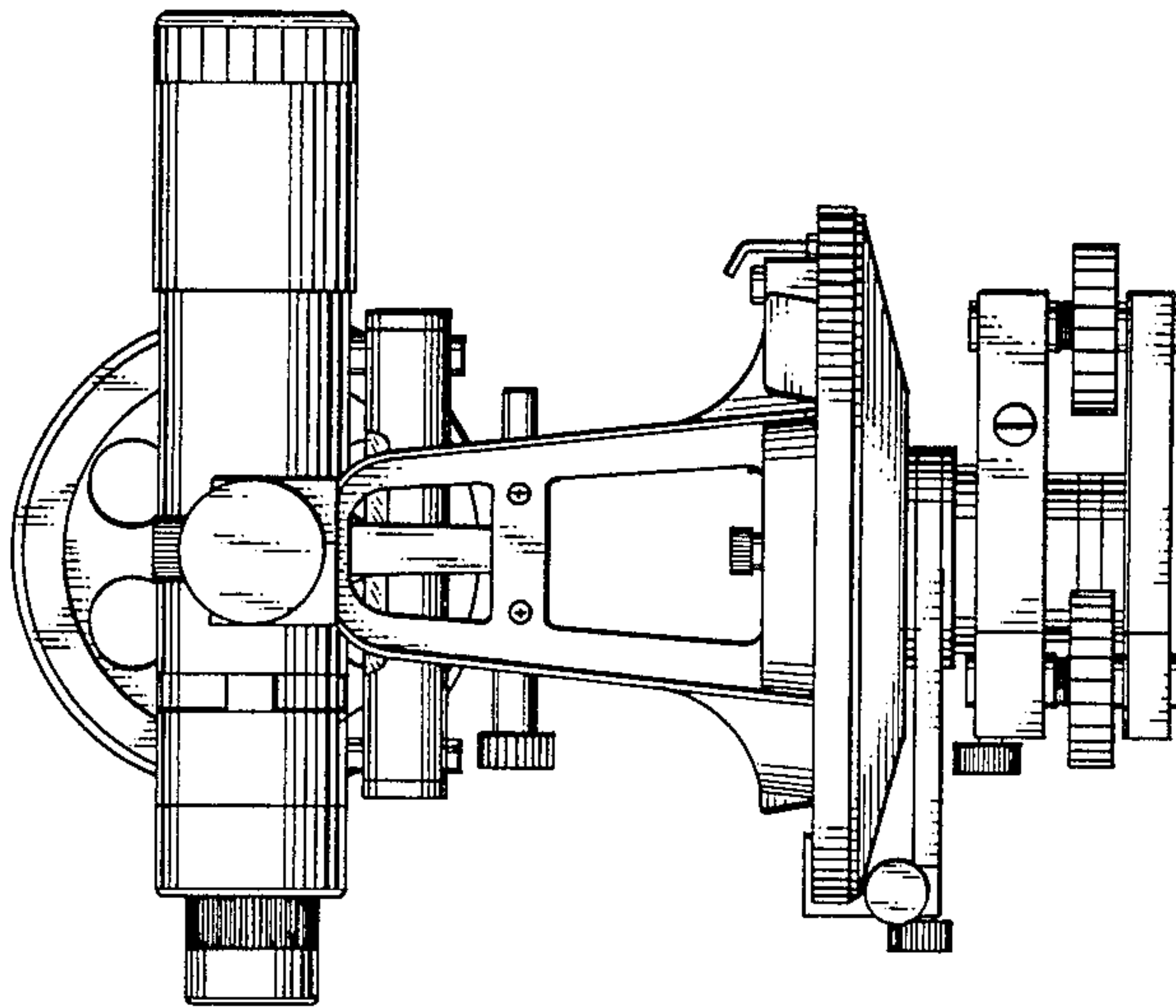

FIG. 7

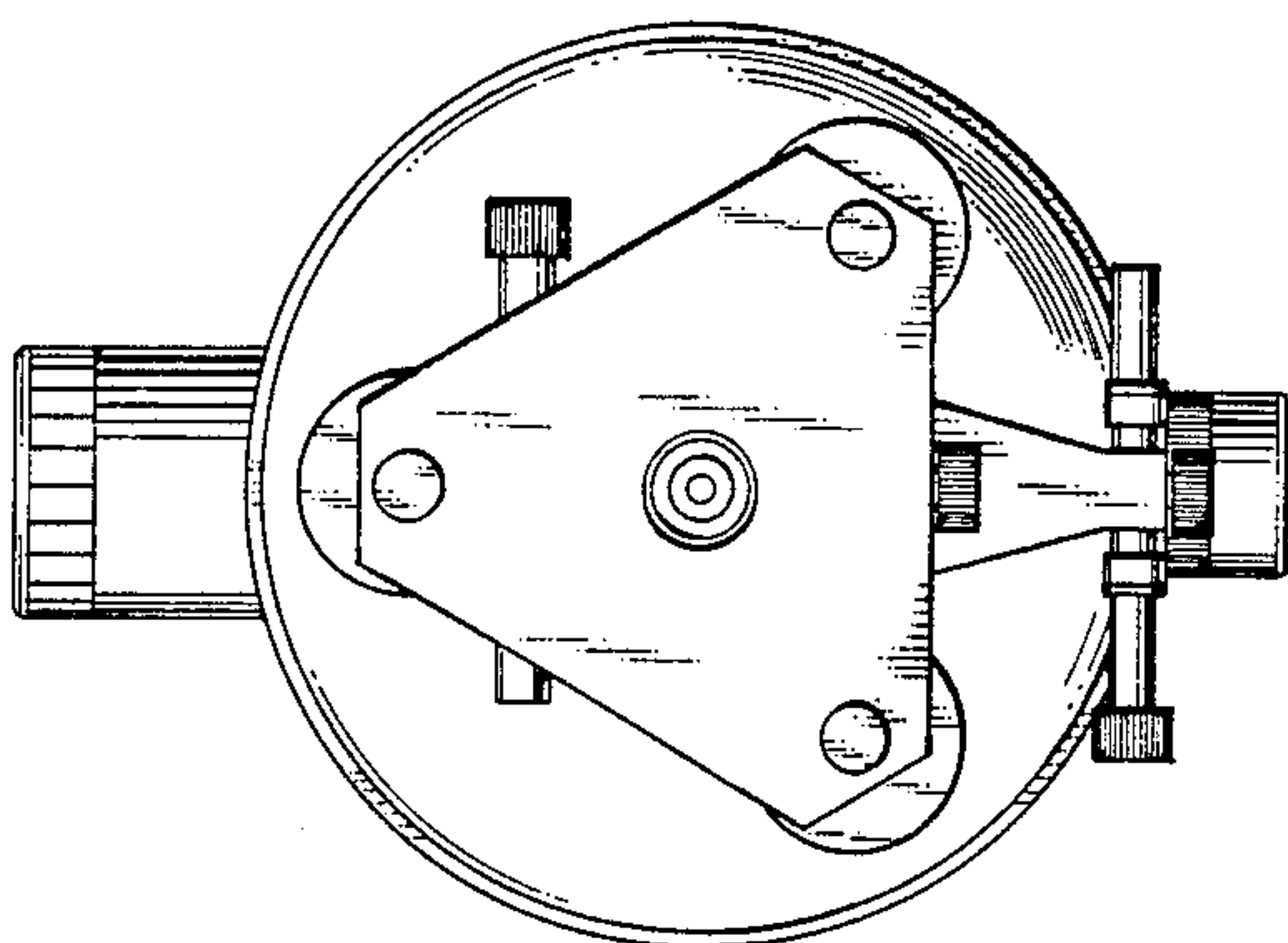

FIG. 6

