

United States Patent [19]

Magaraggia, née Ferrighi

[11] Patent Number: **Des. 311,113**

[45] Date of Patent: **** Oct. 9, 1990**

[54] **COMBINED SALT AND PEPPER CONTAINER**

[75] Inventor: **Antonietta Magaraggia, née Ferrighi, Verbania Suna, Italy**

[73] Assignee: **A.C.E.A. Manodomeistici S.r.L., Casale Corte Cerro, Italy**

[**] Term: **14 Years**

[21] Appl. No.: **138,119**

[22] Filed: **Dec. 28, 1987**

[30] **Foreign Application Priority Data**

Jul. 1, 1987 [IT] Italy 21924/87[U]

[52] U.S. Cl. **D7/596**

[58] Field of Search **D7/52-58; D9/366, 359, 364; 241/168, 169, 169.1; 222/142.1-142.9**

[56] **References Cited**

U.S. PATENT DOCUMENTS

3,122,275 2/1964 Maxim 222/142.4

Primary Examiner—Bernard Ansher

Assistant Examiner—Terry A. Pfeffer

Attorney, Agent, or Firm—Guido Modiano; Albert Josif

[57] **CLAIM**

The ornamental design for combined salt and pepper container, as shown and described.

DESCRIPTION

FIG. 1 is a perspective view of the combined salt and pepper container showing my new design;

FIG. 2 is a perspective view thereof, in an open position;

FIG. 3 is a side elevational view thereof, the opposite side being a mirror image;

FIG. 4 is a front elevational view thereof;

FIG. 5 is a rear elevational view thereof; and

FIG. 6 is a top plan view thereof, the opposite side being a mirror image.

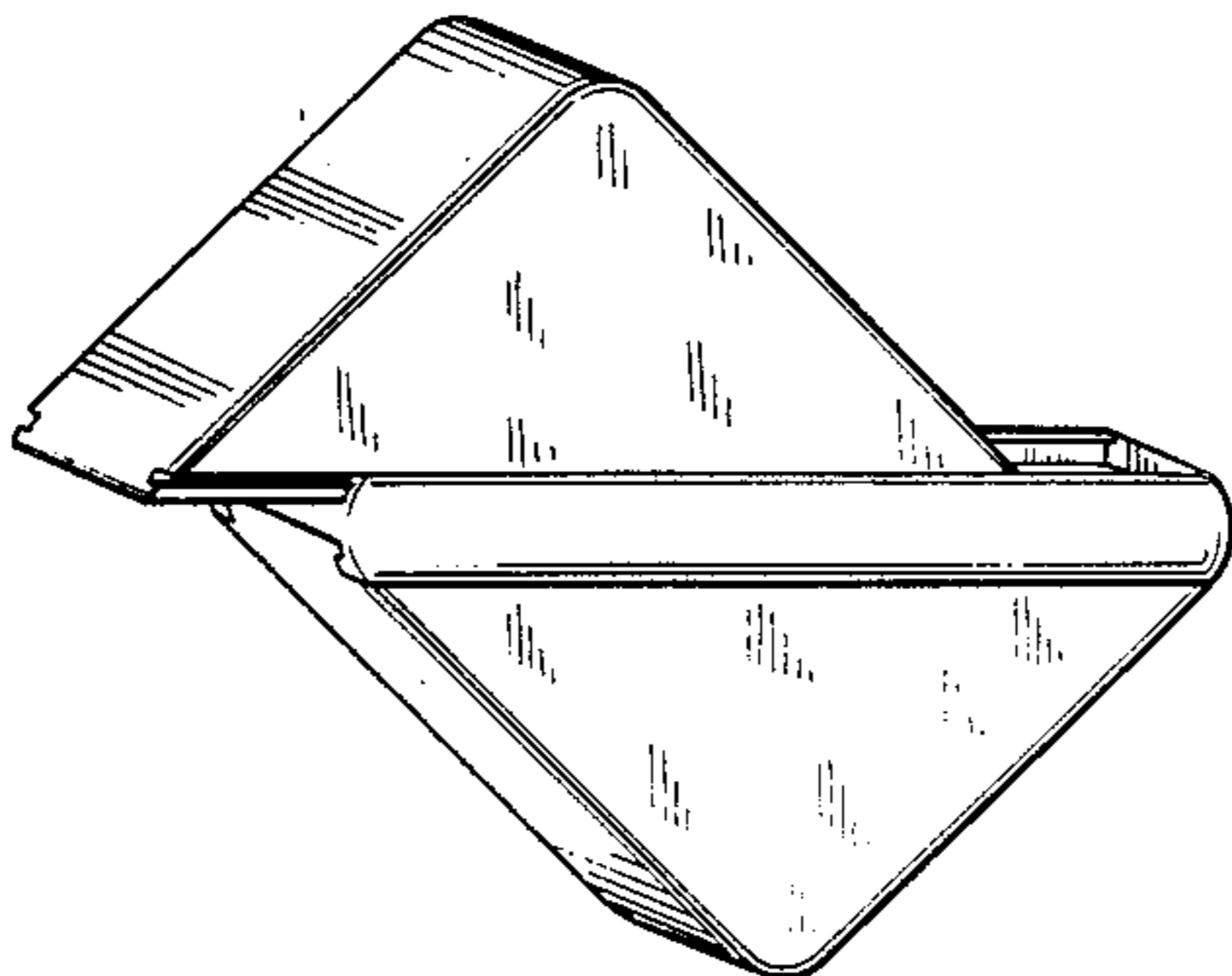
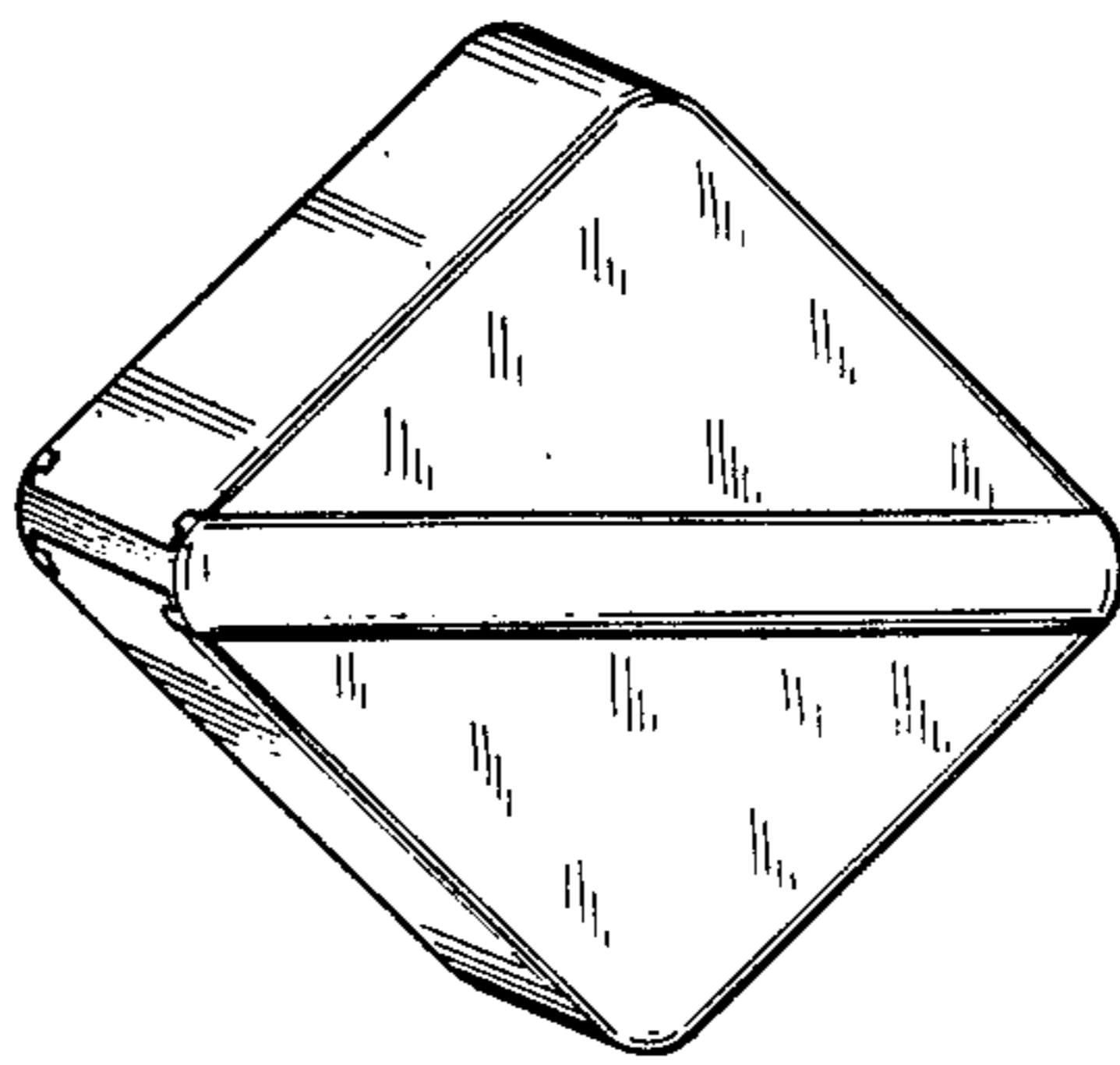

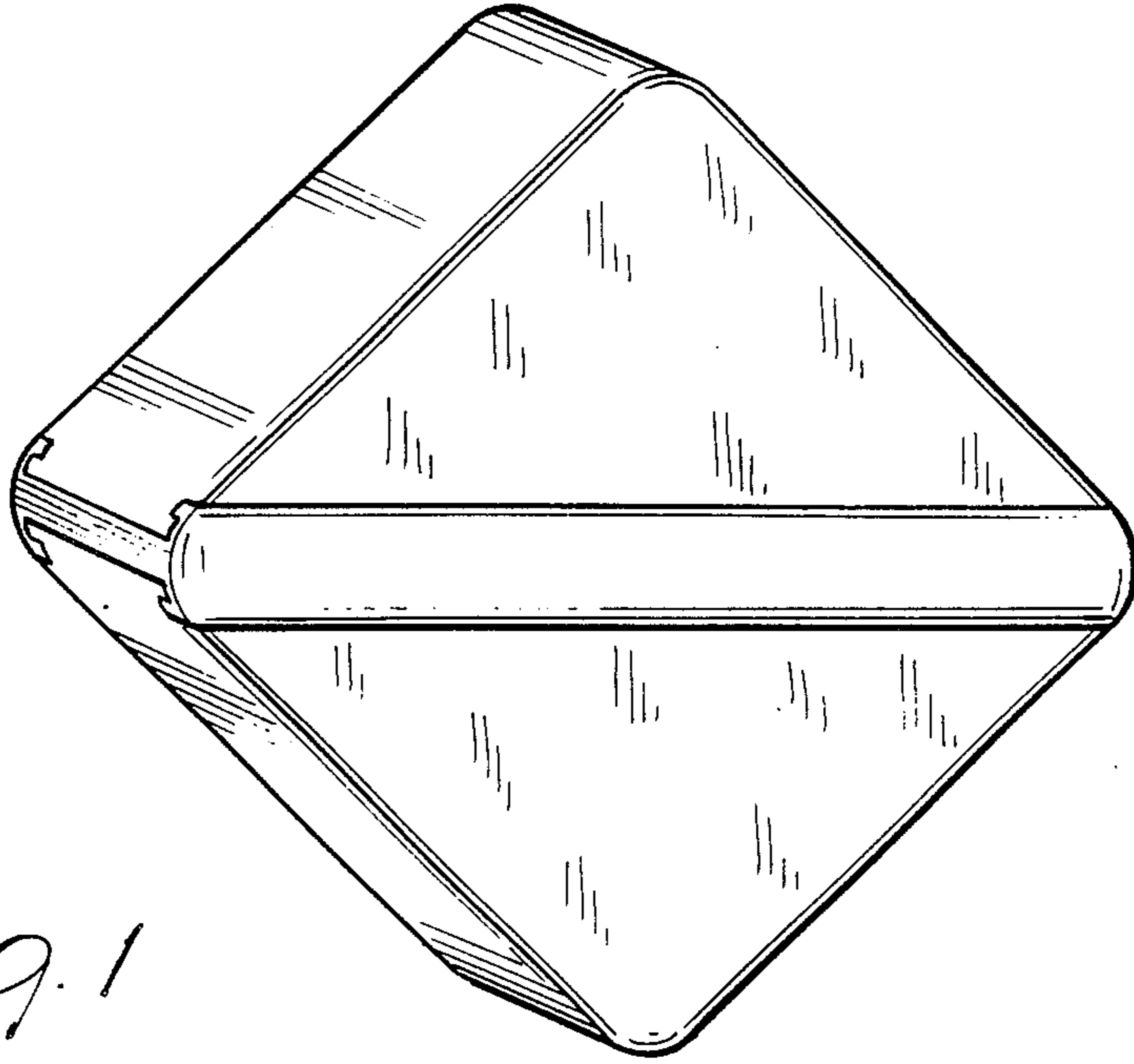

FIG. 1

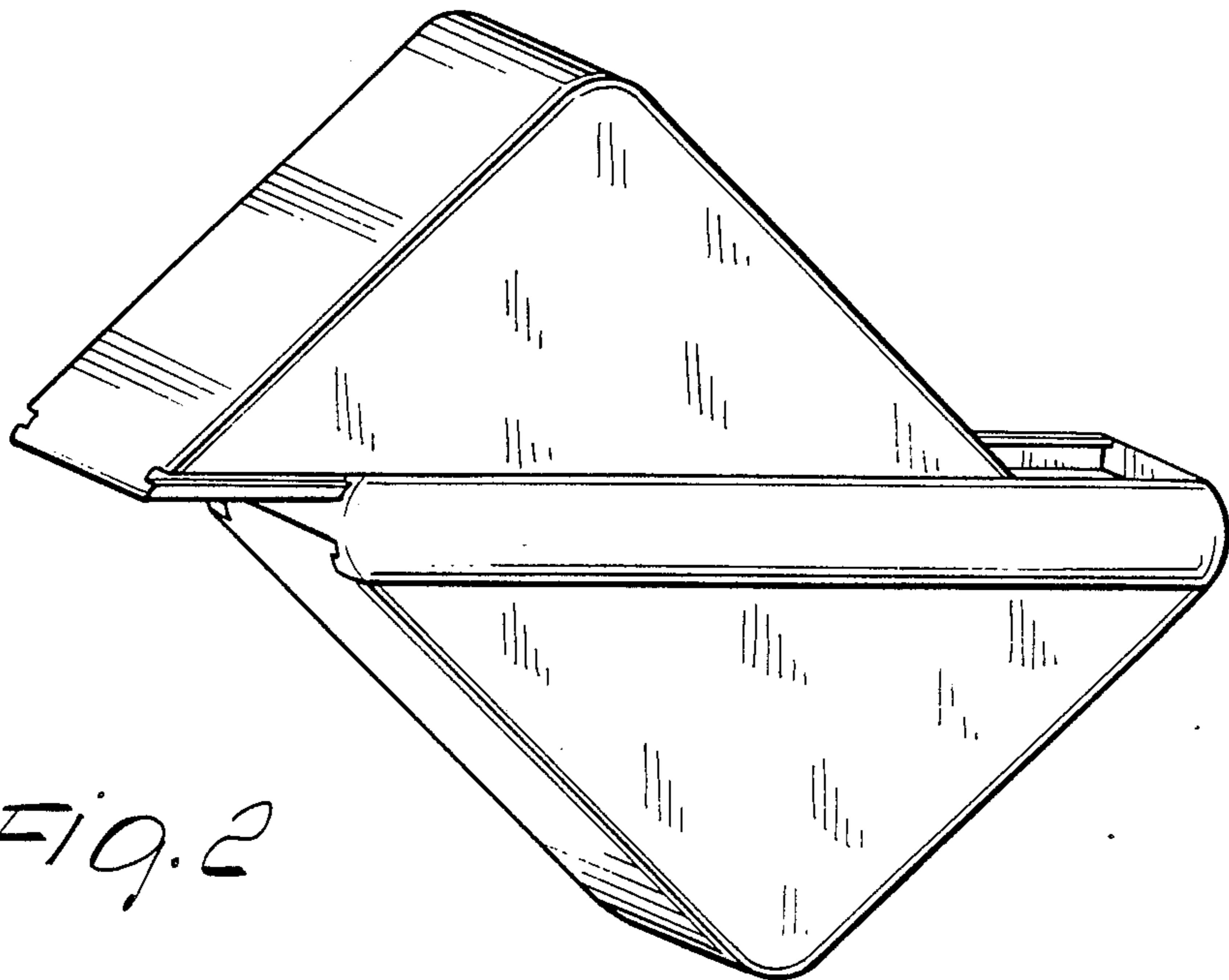

FIG. 2

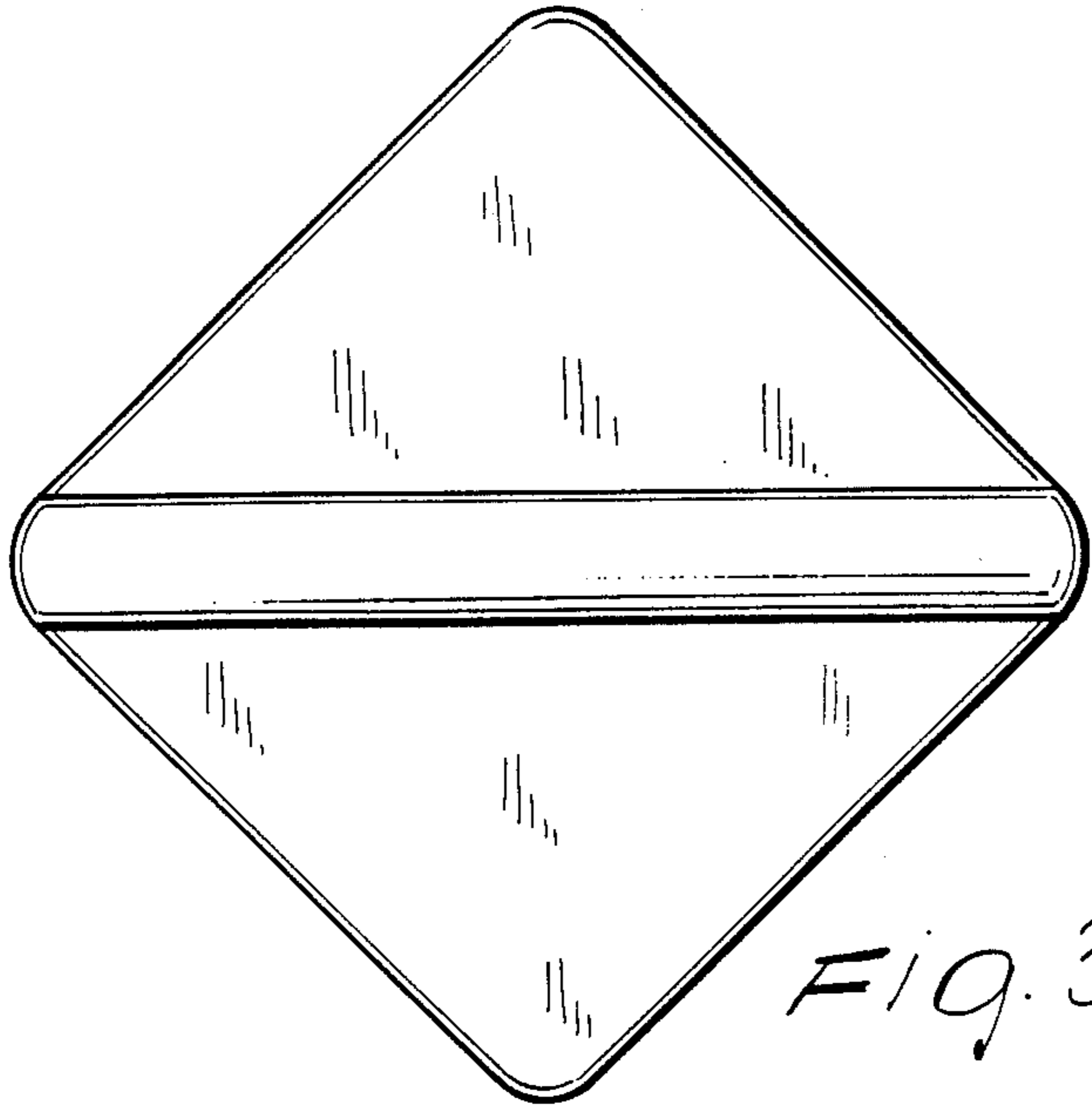

FIG. 3

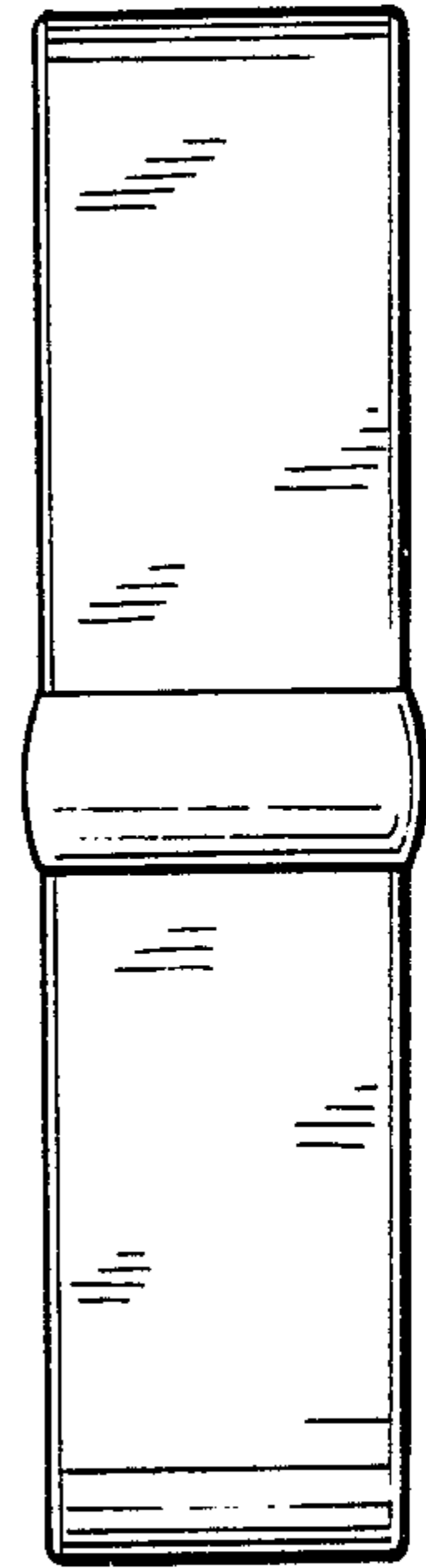

FIG. 5

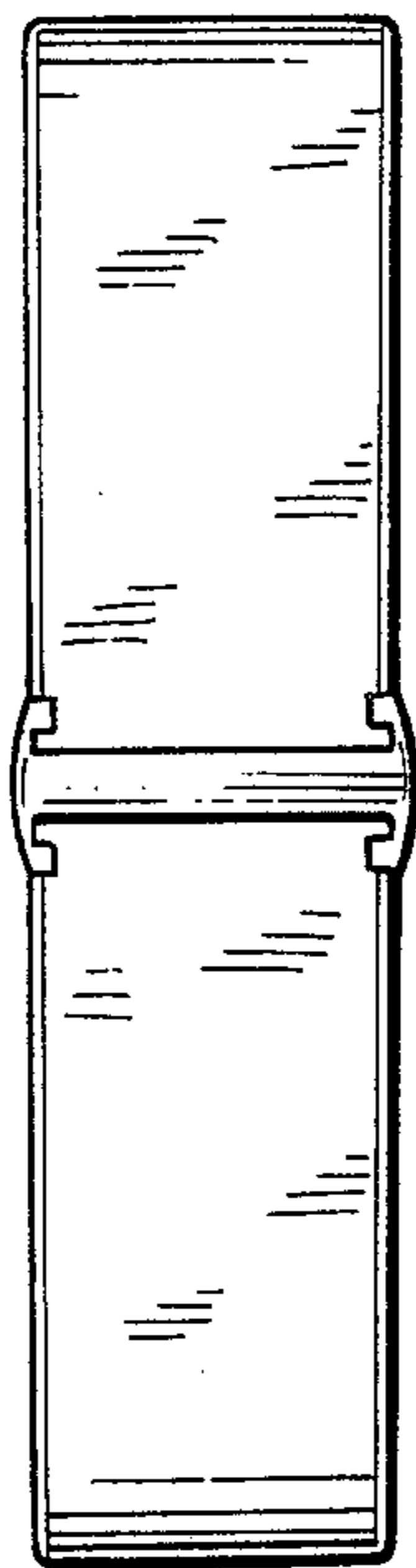

FIG. 4

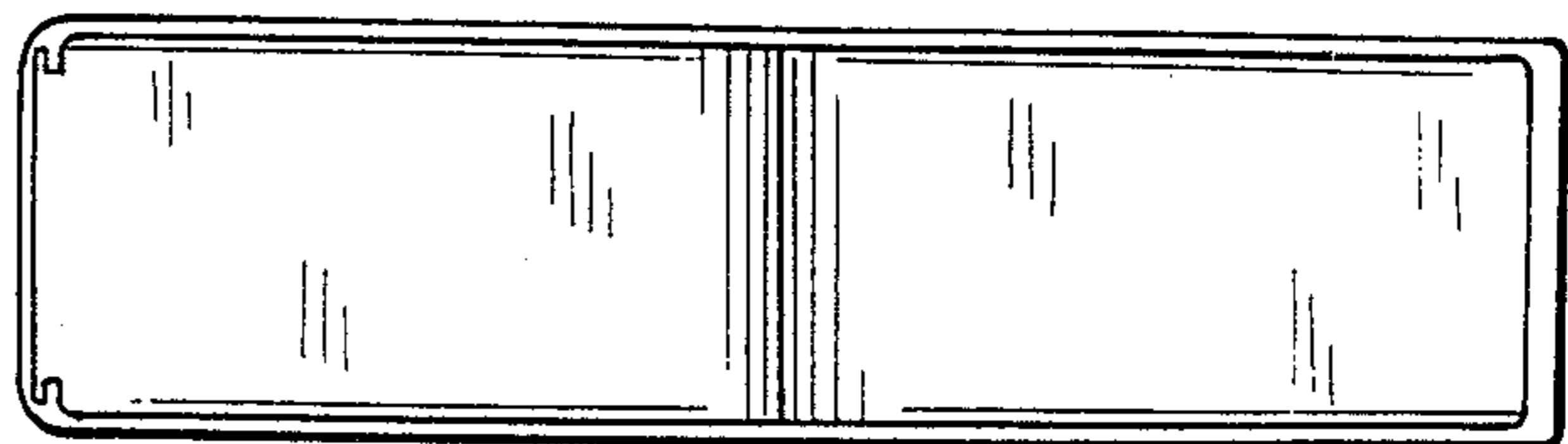

FIG. 6