

[54] ELECTRICAL CONNECTOR ASSEMBLY

[75] Inventors: Kenzi Ohkura, Hisai; Sho-Ichi Sugata, Suzuka, both of Japan

[73] Assignee: Sumitomo Wiring Systems, Ltd., Suzuka, Japan

[**] Term: 14 Years

[21] Appl. No.: 143,104

[22] Filed: Jan. 11, 1988

[30] Foreign Application Priority Data

Jul. 10, 1987 [JP] Japan 62-28166
Jul. 10, 1987 [JP] Japan 62-28167

[52] U.S. Cl. D13/146

[58] Field of Search D13/133, 146; 439/344, 439/353, 357, 660, 682, 685, 686, 687, 695, 696, 712, 713, 350, 600, 701, 748

[56] References Cited

U.S. PATENT DOCUMENTS

3,501,736 3/1970 Norris 439/353
4,655,527 4/1987 Vandame 439/350
4,682,839 7/1987 Bryce 439/701 X
4,690,478 9/1987 Rahrig et al. 439/748 X
4,772,231 9/1988 Hayes 439/600 X

Primary Examiner—Susan J. Lucas
Assistant Examiner—Joel Sincavage
Attorney, Agent, or Firm—Liddy Sullivan Galway
Begler & Peroff

[57] CLAIM

The ornamental design for an electrical connector assembly, as shown and described.

DESCRIPTION

FIG. 1 is a front perspective view of an electrical connector assembly showing our new design fully assembled;
FIG. 2 is a side elevational view thereof, the opposite side elevational view being a mirror image;
FIG. 3 is a front elevational view thereof;
FIG. 4 is a rear elevational view thereof;
FIG. 5 is a top plan view thereof;
FIG. 6 is a bottom plan view thereof;
FIG. 7 is a front perspective view of the female portion of an electrical connector assembly showing our new design, the male portion being omitted for the purpose of a complete disclosure;
FIG. 8 is a side elevational view thereof, the opposite side elevational view being a mirror image;
FIG. 9 is a front elevational view thereof;
FIG. 10 is a rear elevational view thereof;
FIG. 11 is a top plan view thereof;
FIG. 12 is a bottom plan view thereof;
FIG. 13 is a front perspective view of the male portion of an electrical connector assembly showing our new design, the female portion being omitted for the purpose of a complete disclosure;
FIG. 14 is a side elevational view thereof, the opposite side elevational view being a mirror image.
FIG. 15 is a front elevational view thereof;
FIG. 16 is a rear elevational view thereof;
FIG. 17 is a top plan view thereof;
FIG. 18 is a bottom plan view thereof;

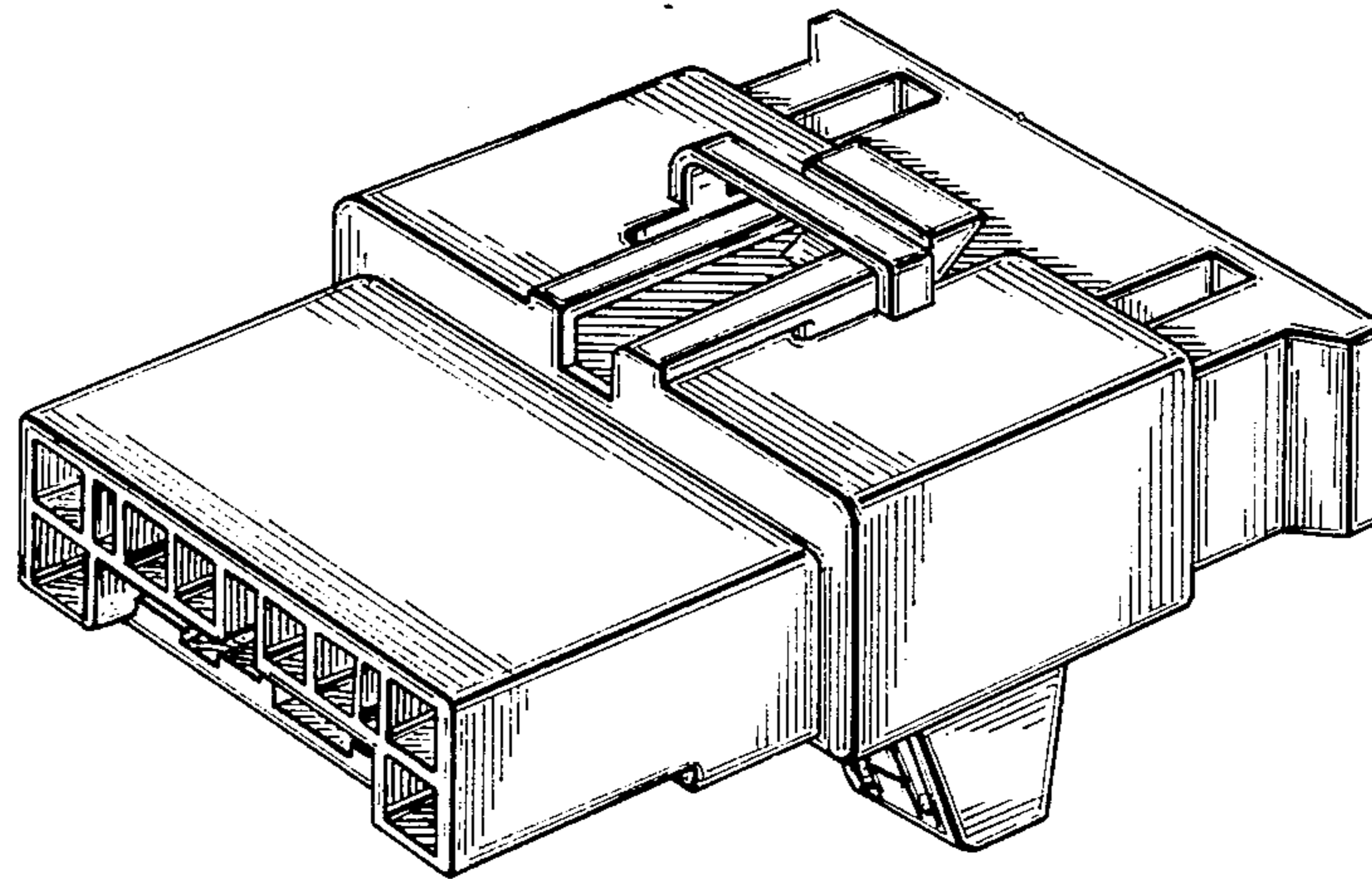

FIG. 1

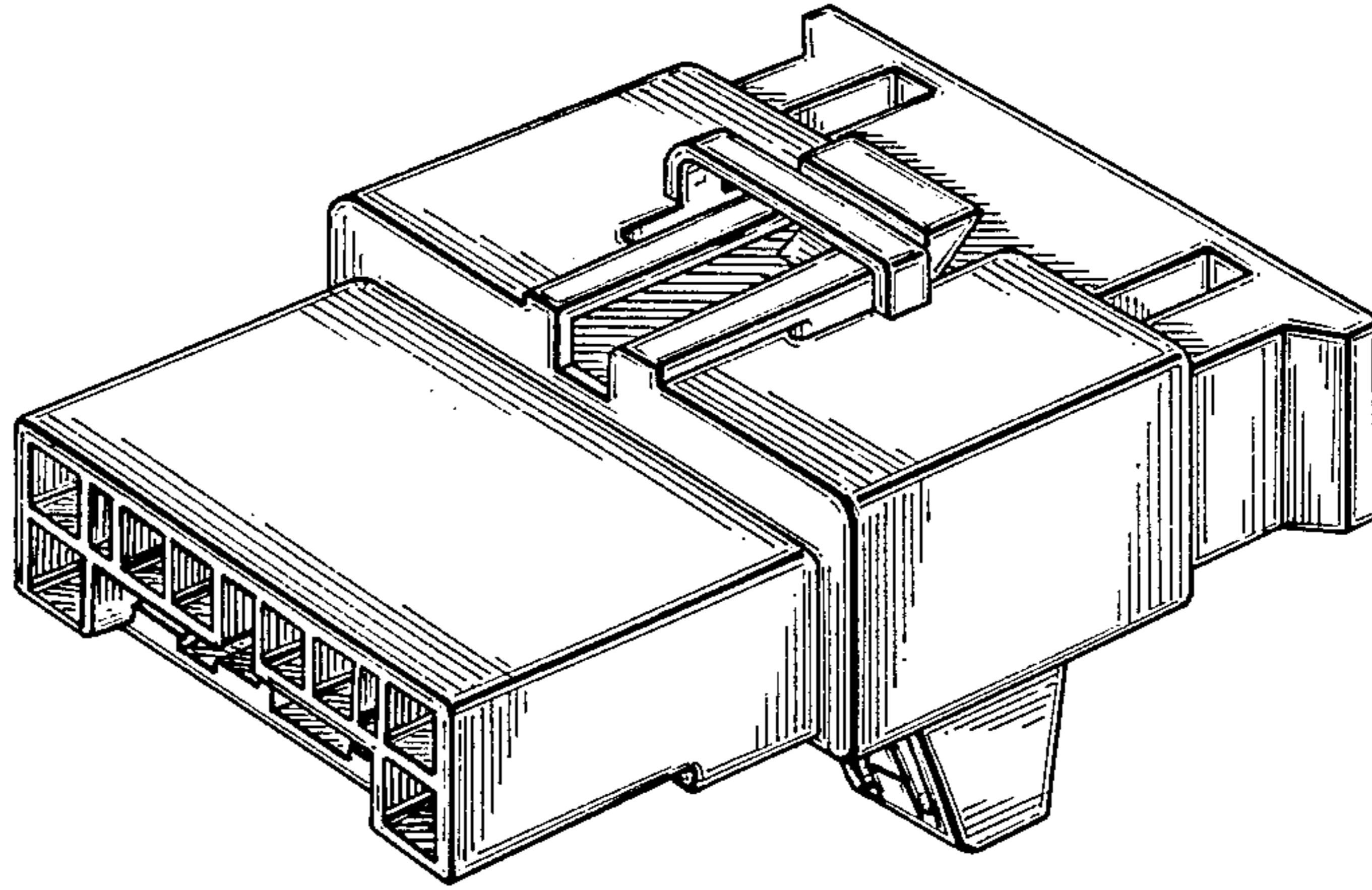

FIG. 2

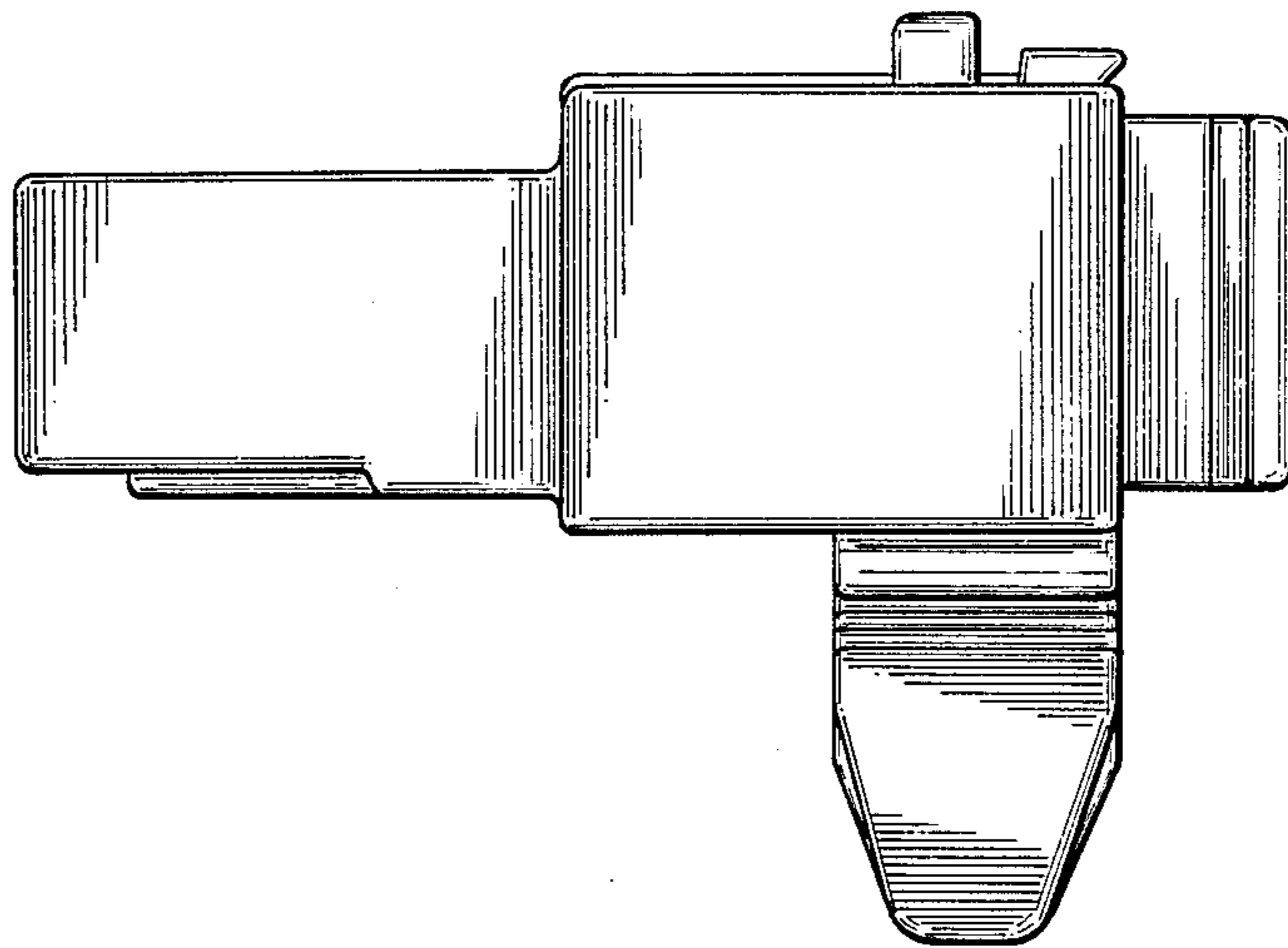

FIG. 3

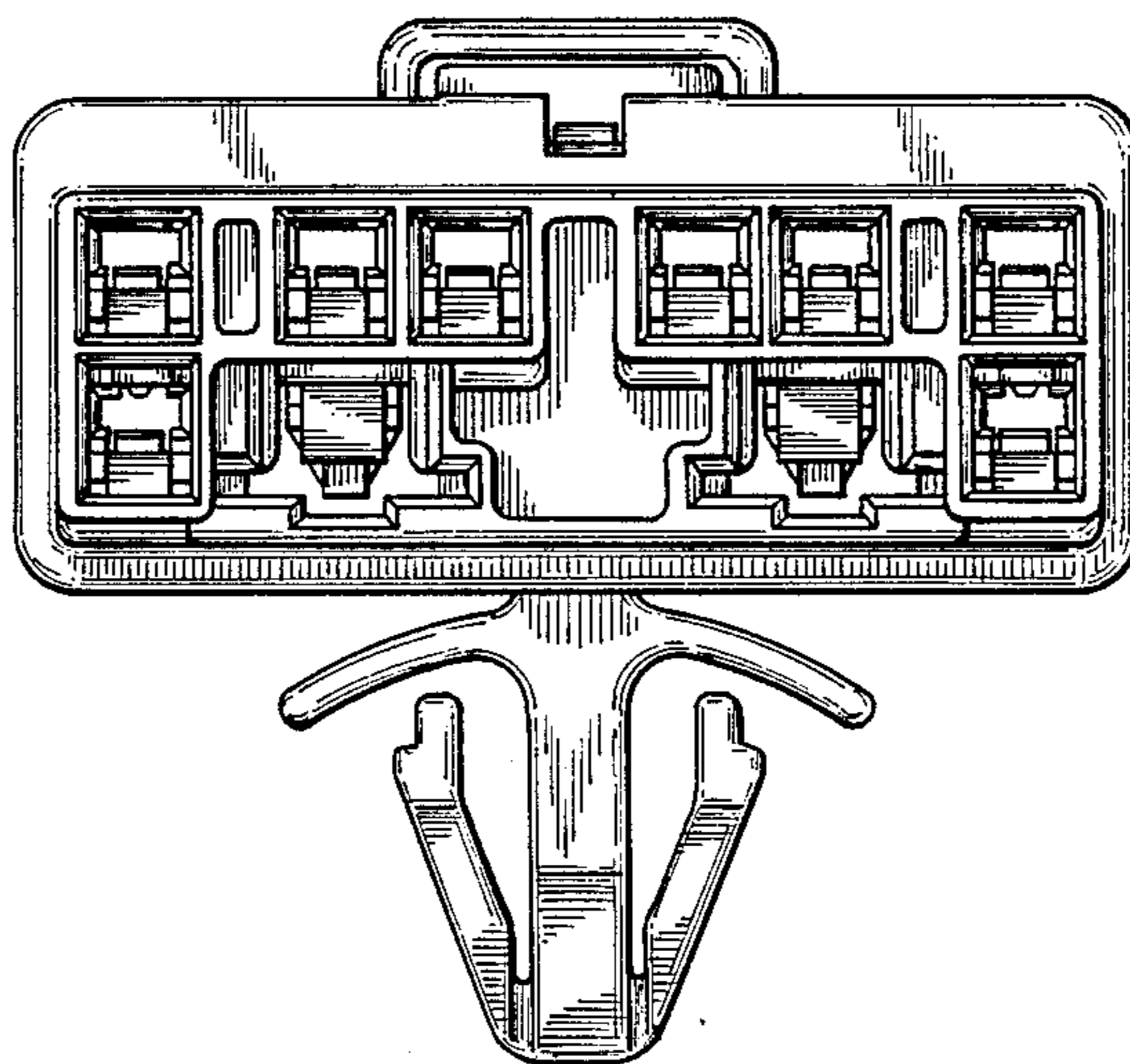

FIG. 4

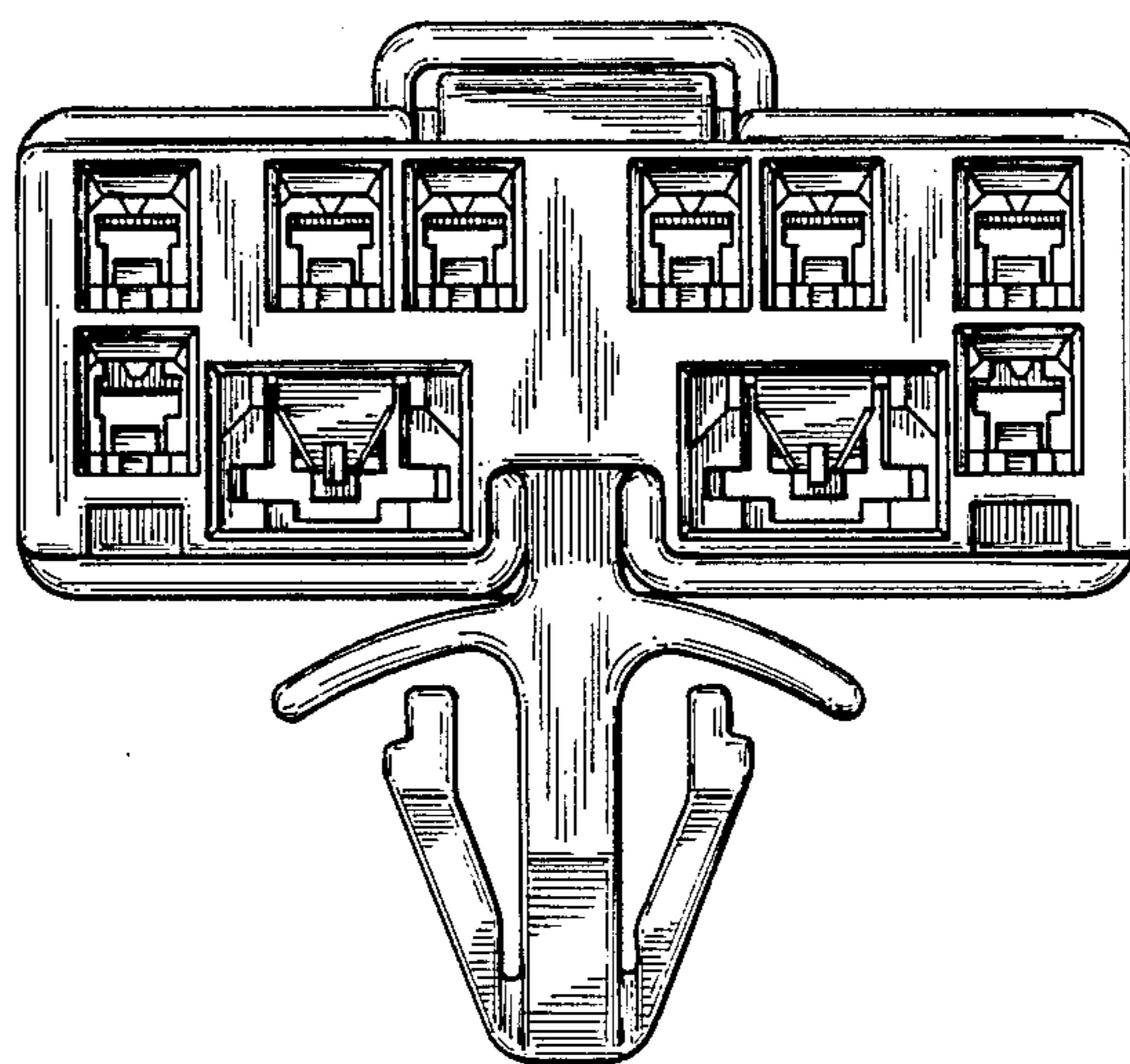

FIG.5

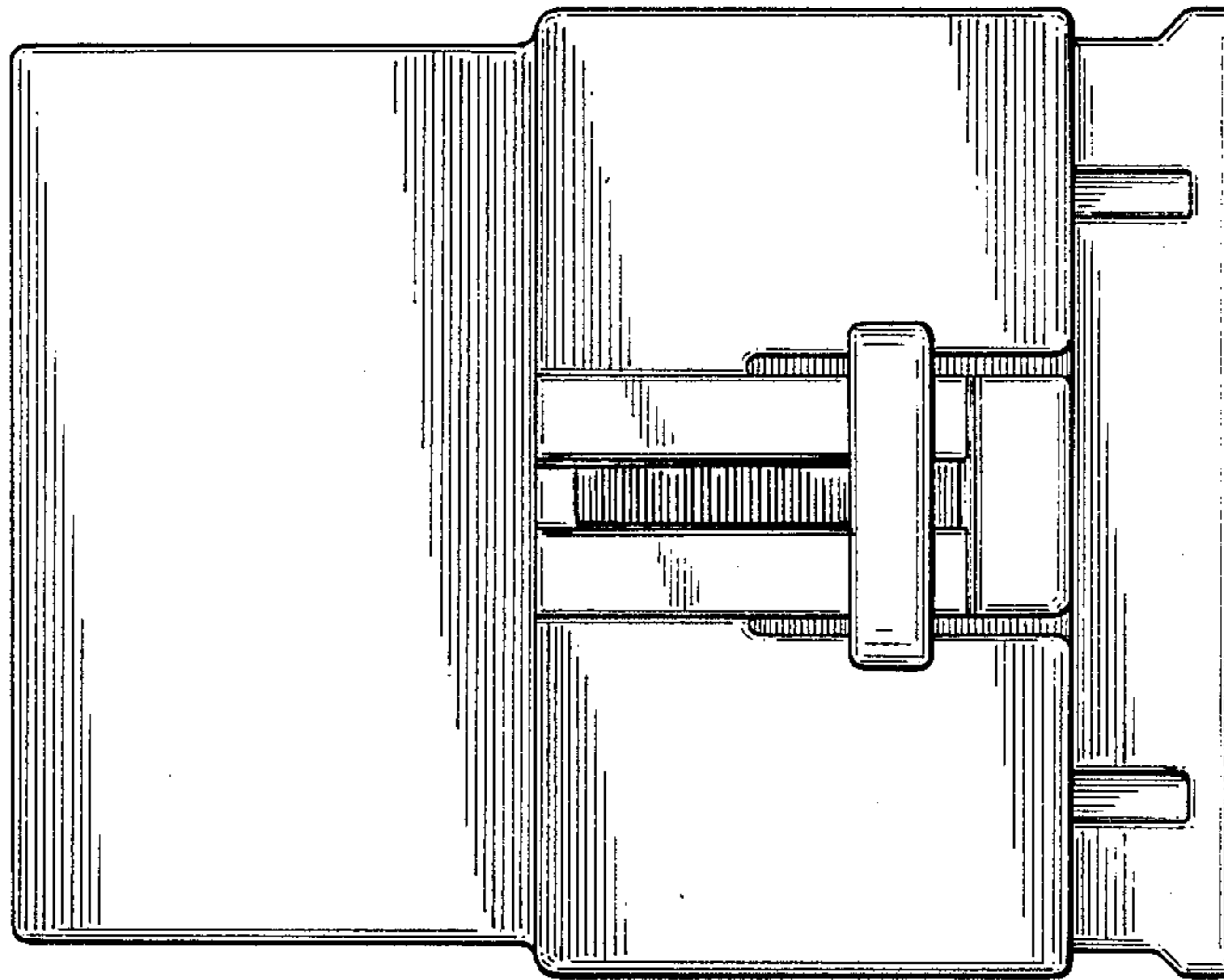

FIG.6

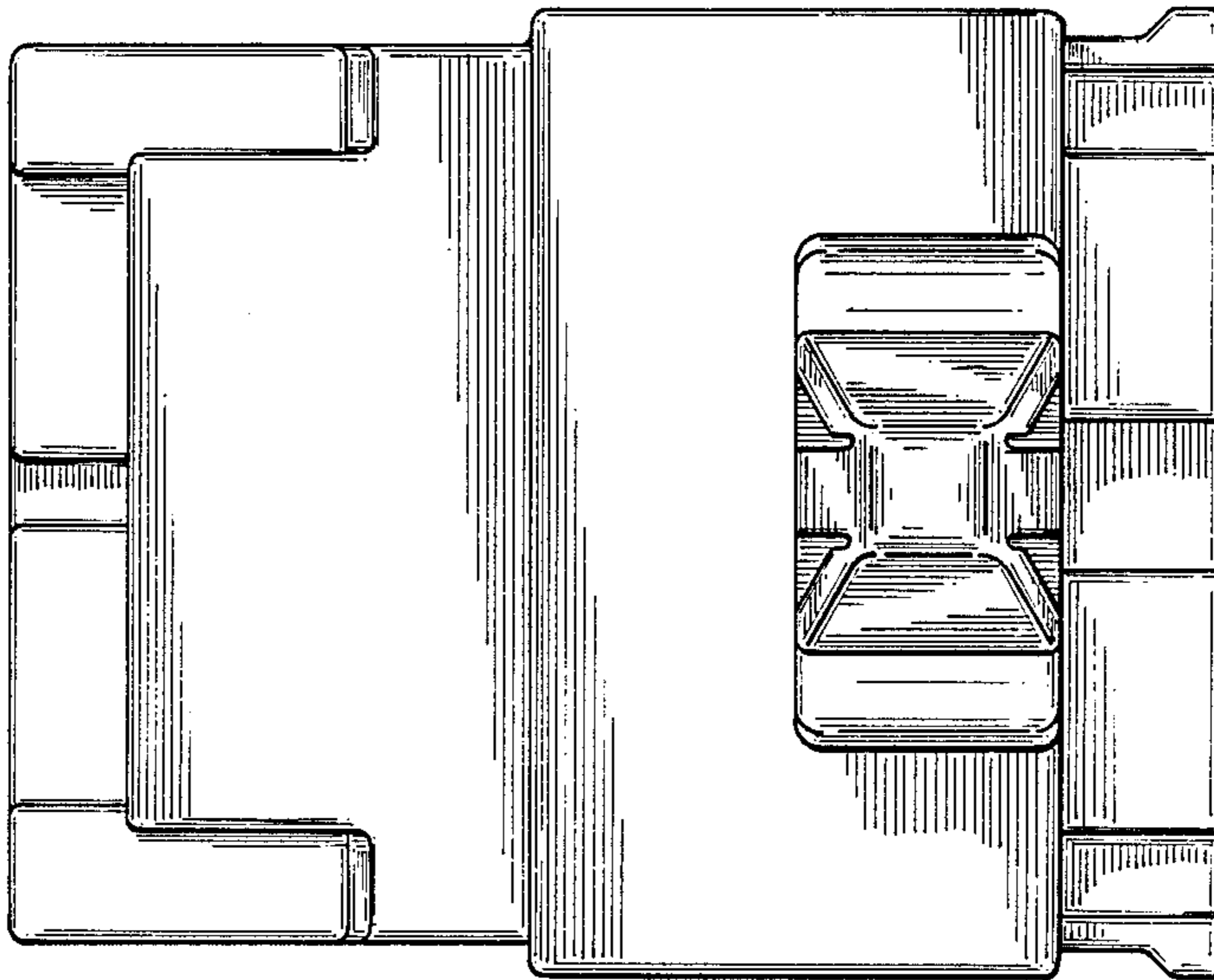

FIG. 7

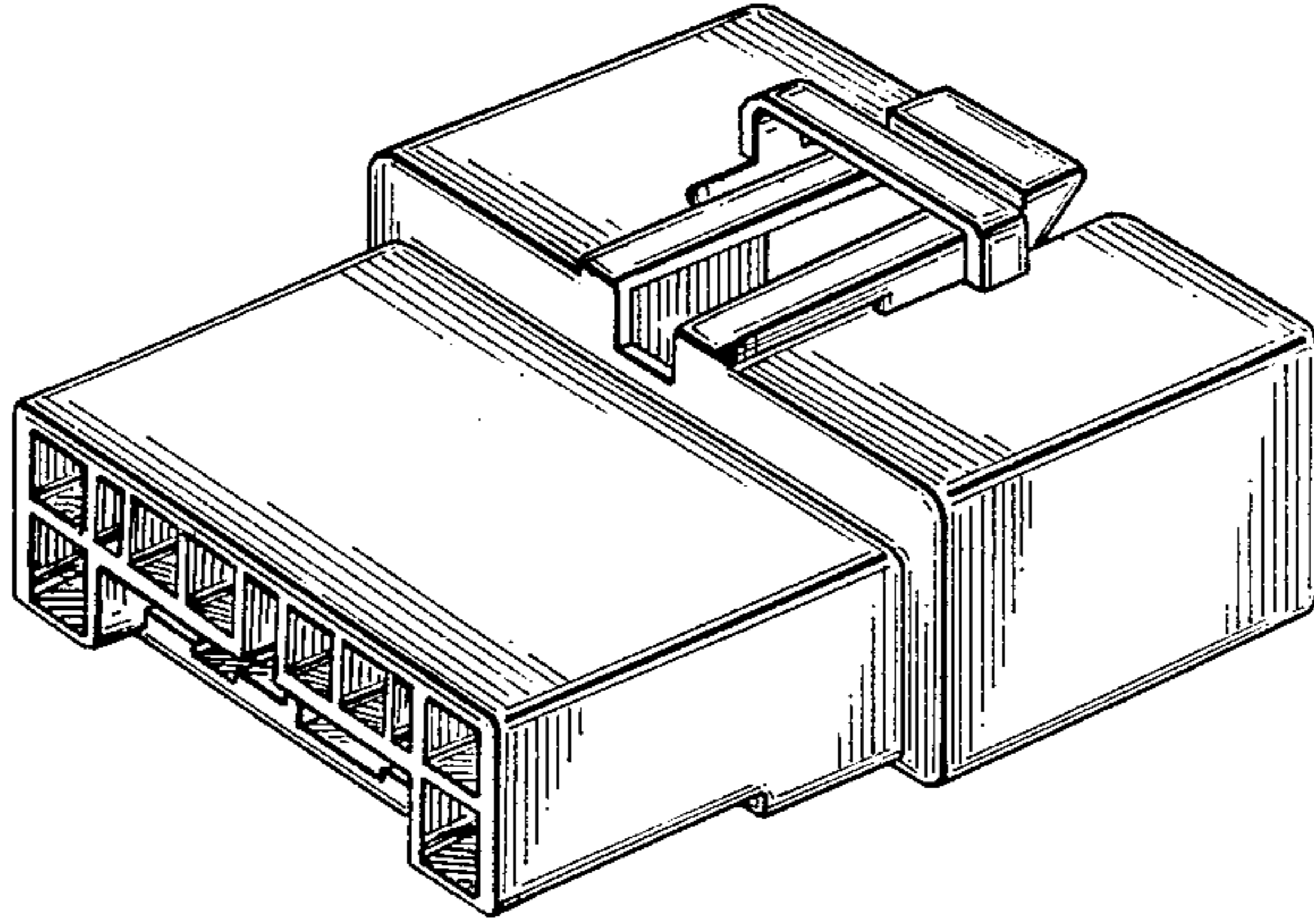

FIG. 8

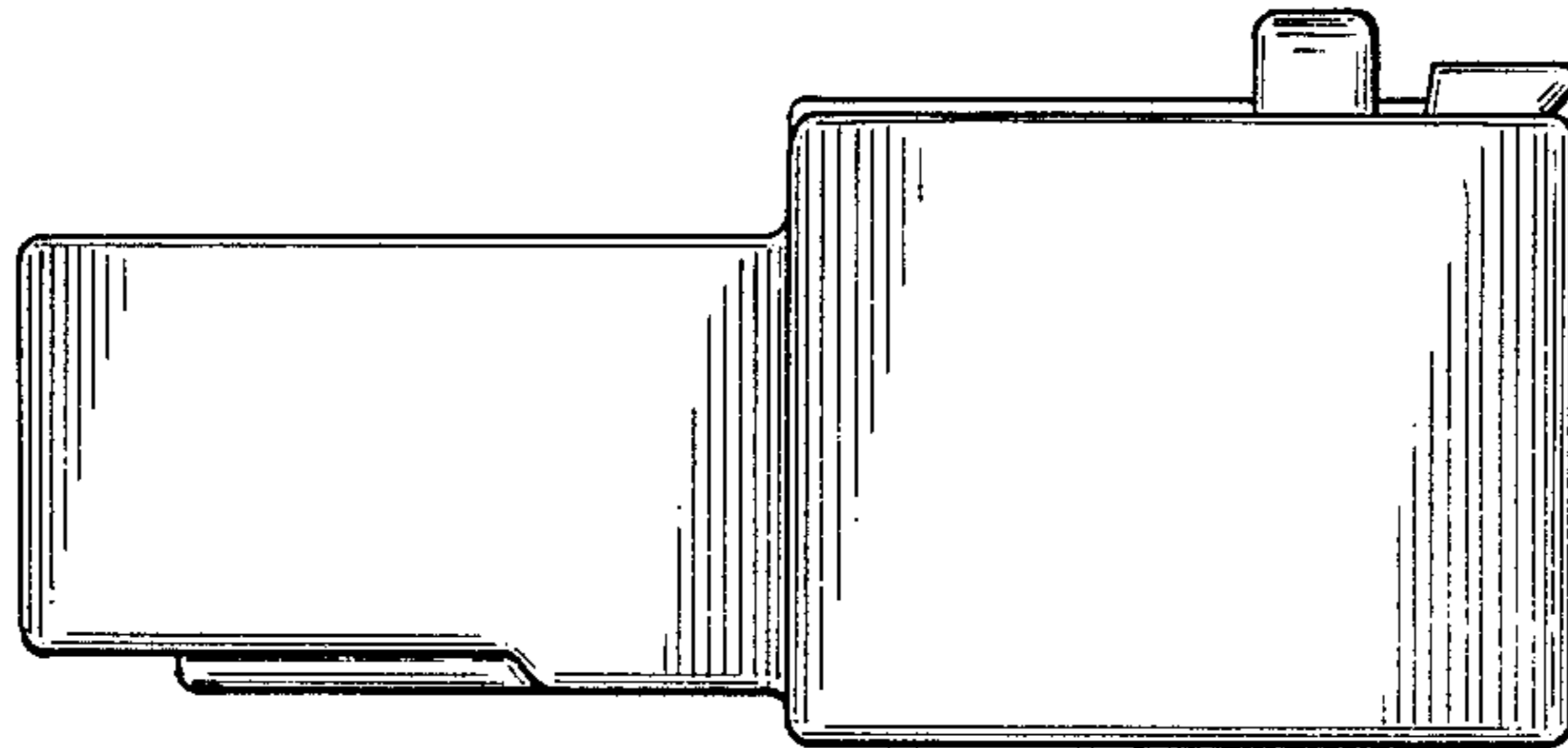

FIG. 9

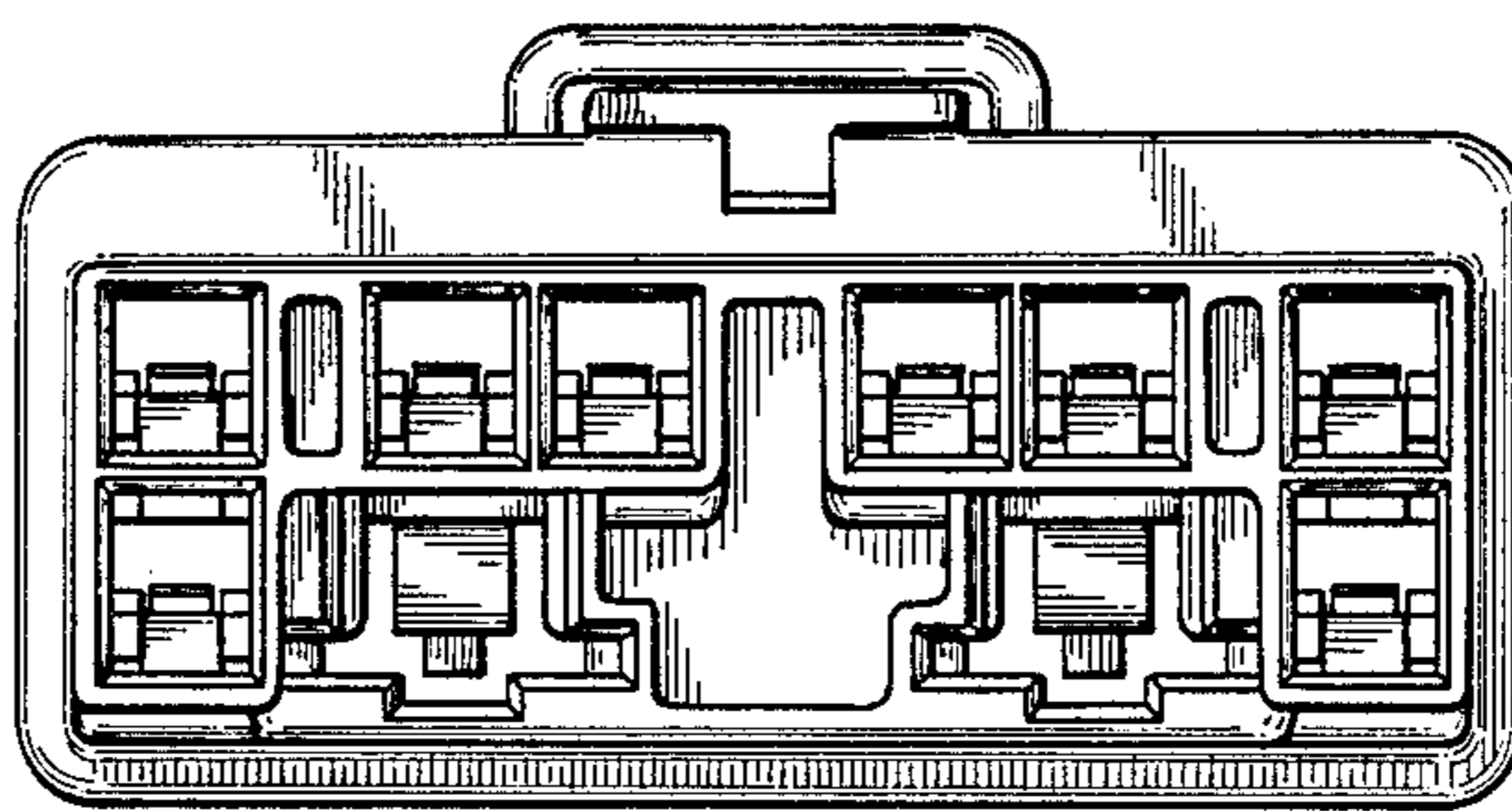

FIG. 10

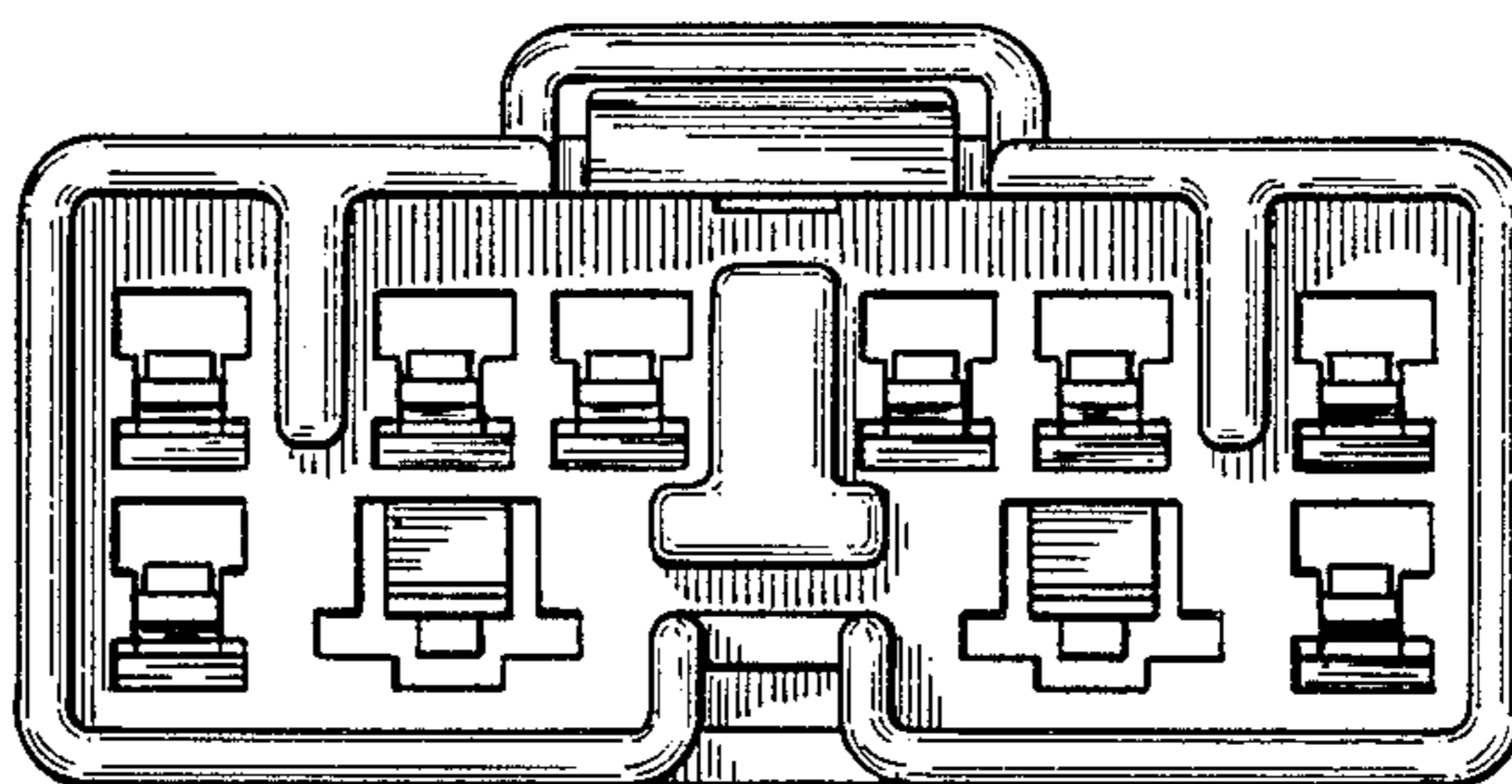

FIG.11

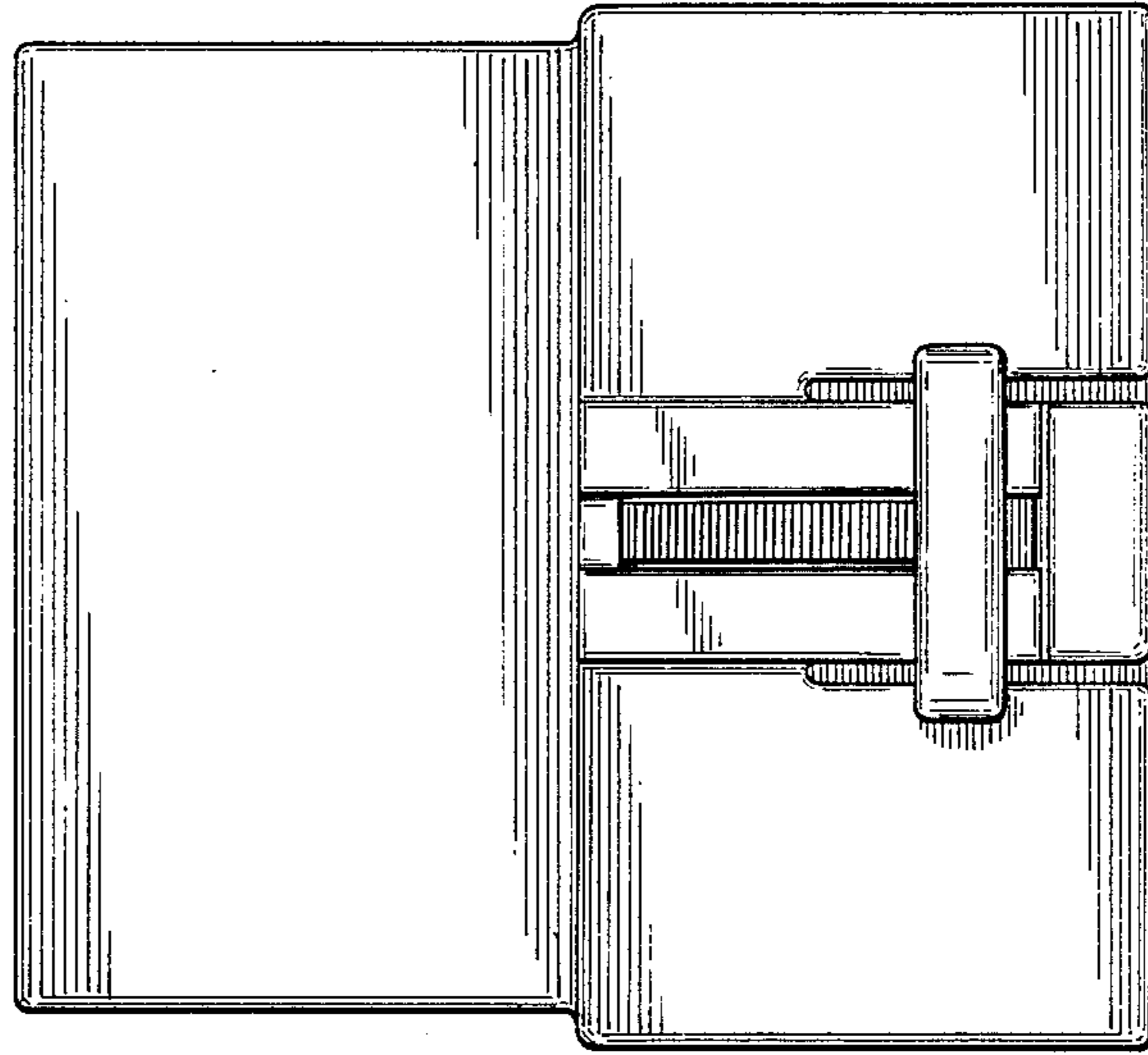

FIG.12

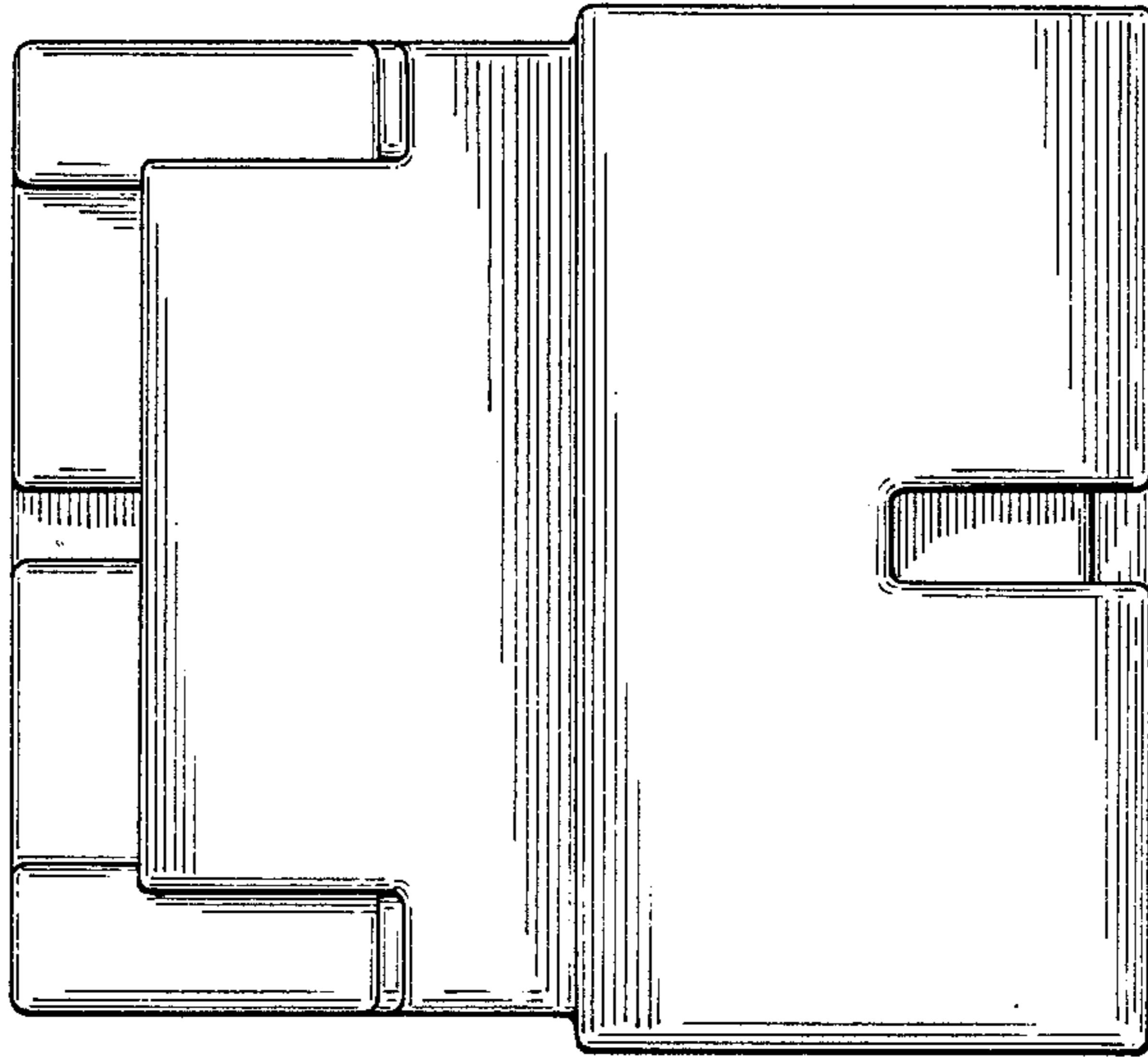

FIG.13

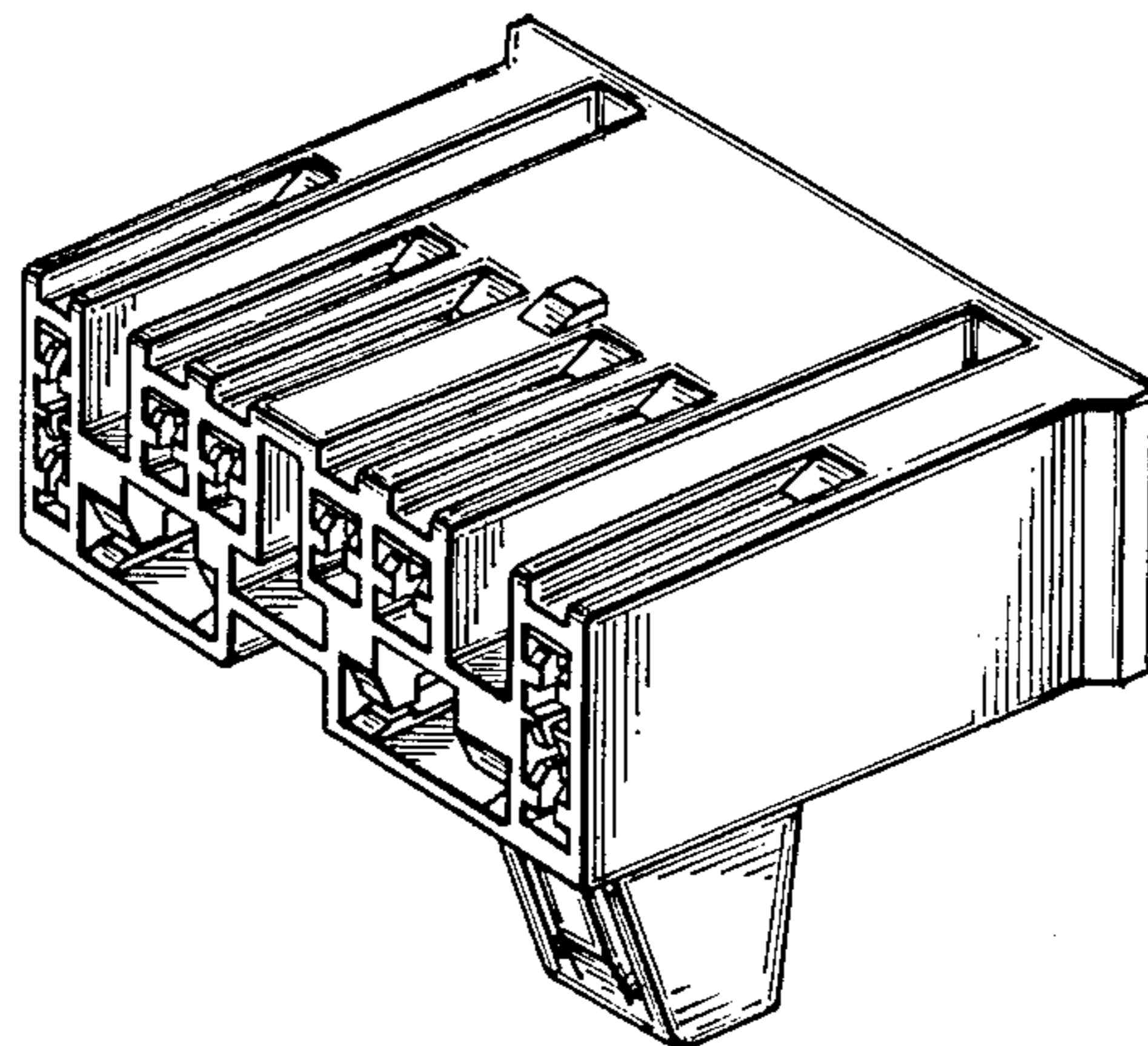

FIG.14

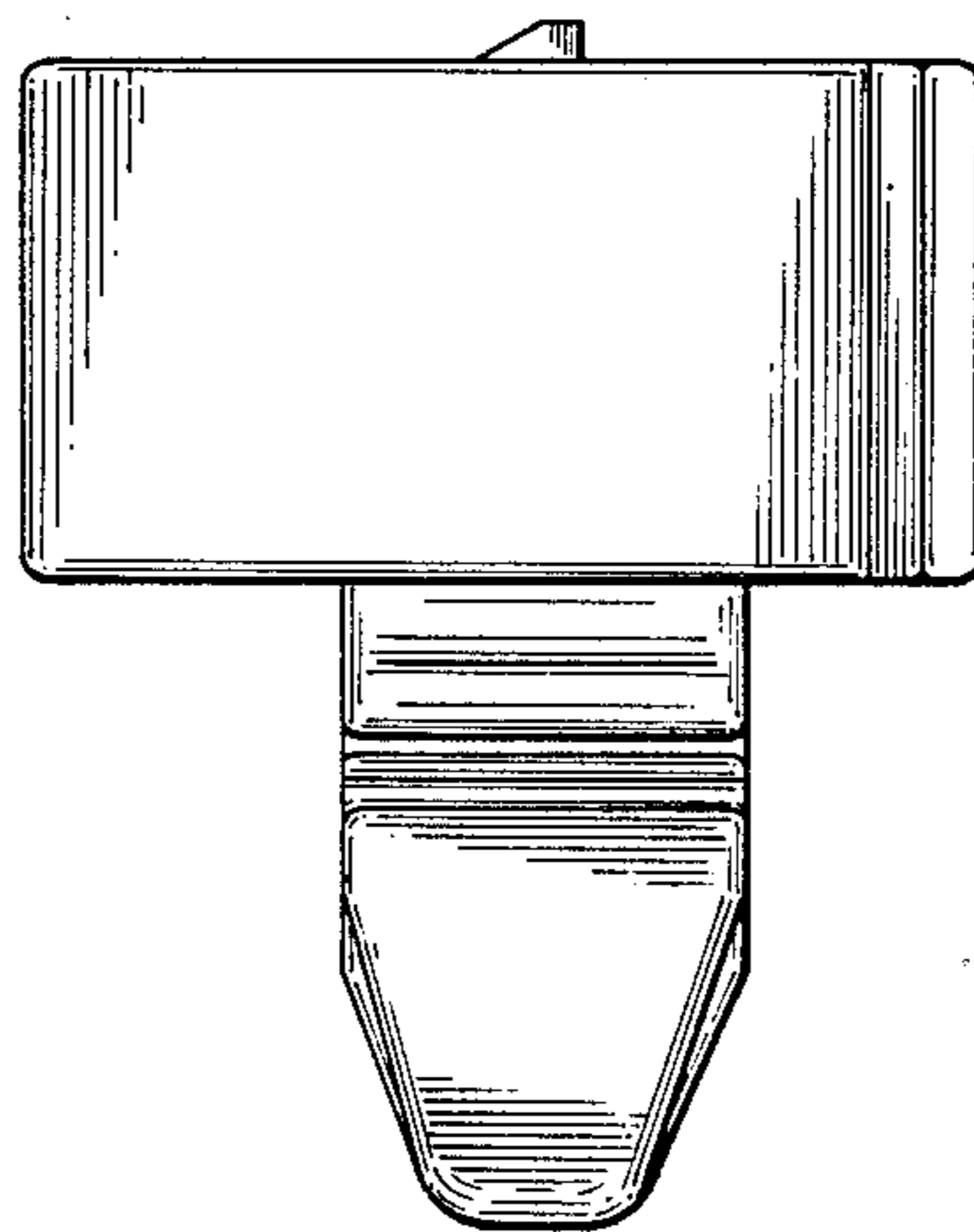

FIG. 15

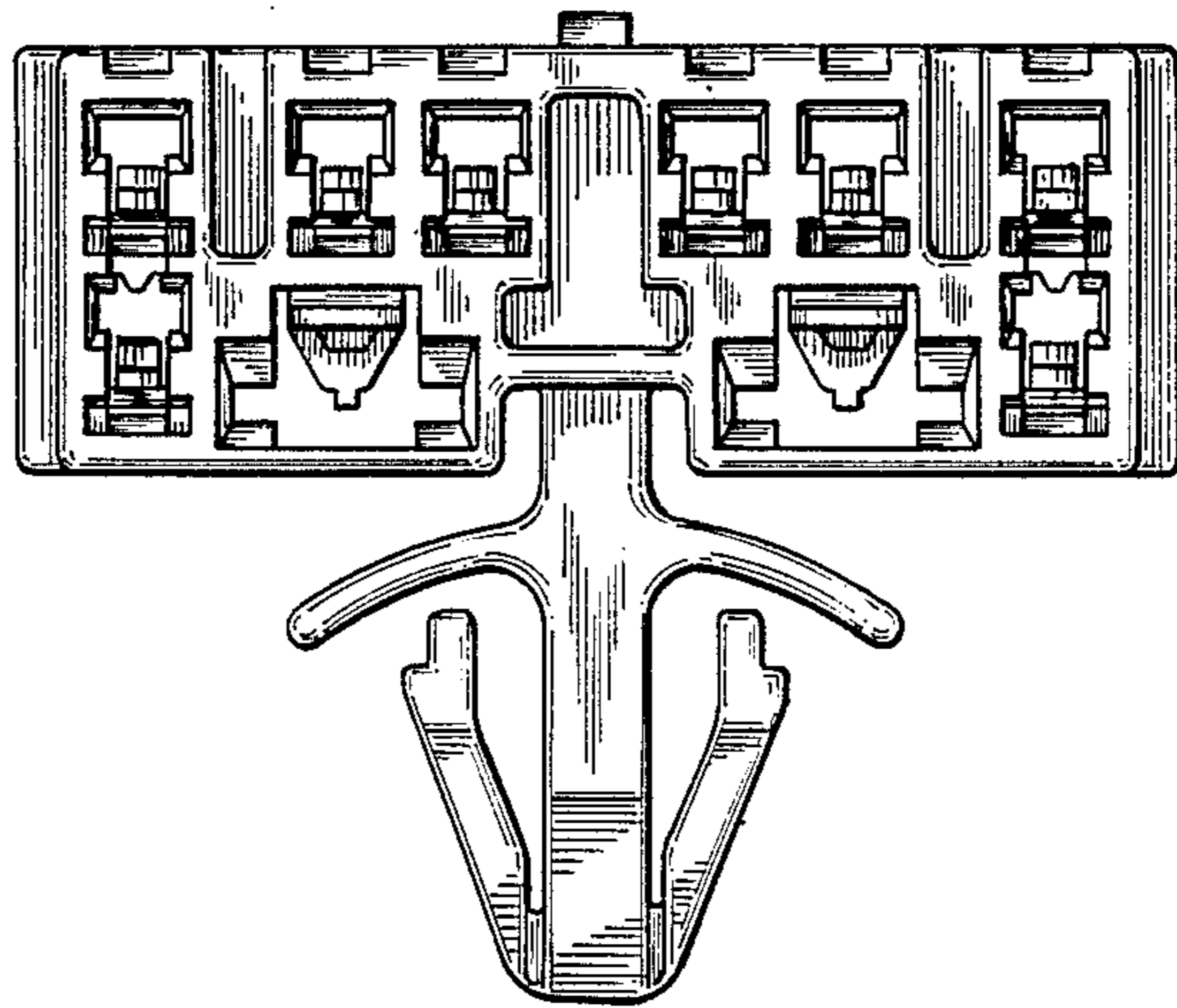

FIG. 16

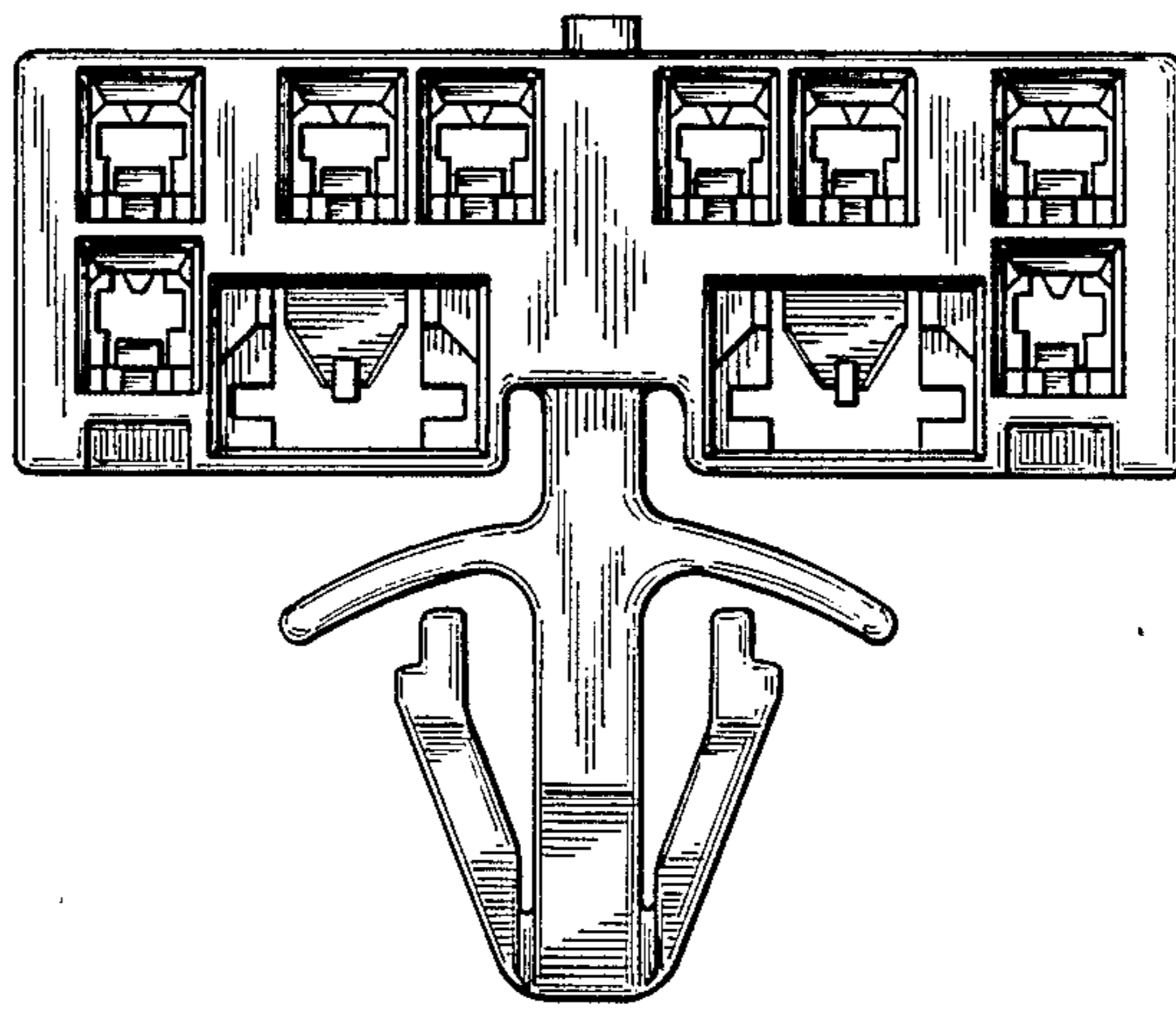

FIG.17

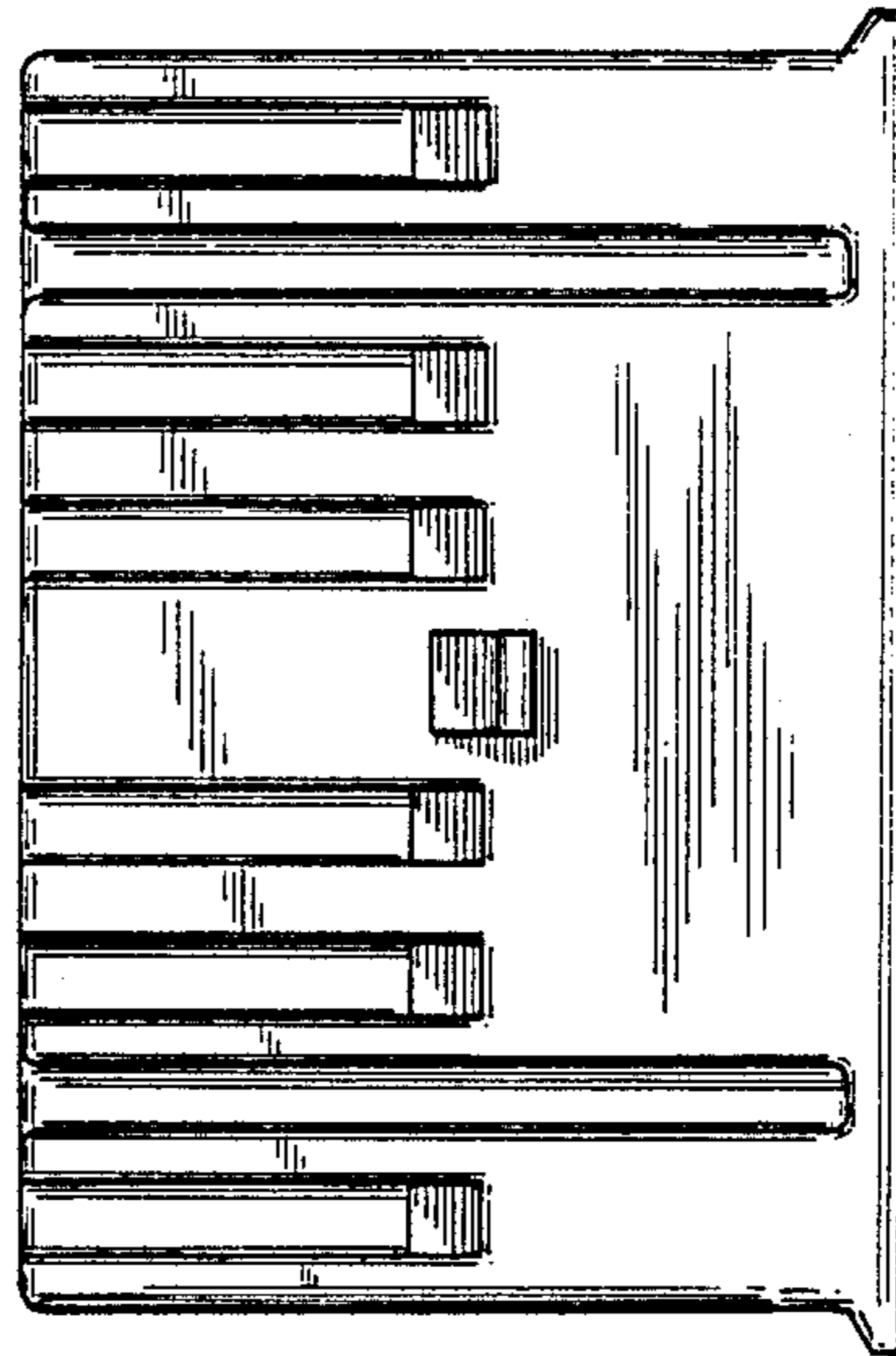

FIG.18

