

[54] **VEHICLE WHEEL SEGMENT**
[75] **Inventor: Maurice P. Chandler, Utica, Mich.**
[73] **Assignee: General Motors Corporation, Detroit, Mich.**
[**] **Term: 14 Years**
[21] **Appl. No.: 212,369**
[22] **Filed: Jun. 27, 1988**
[52] **U.S. Cl. D12/212**
[58] **Field of Search D12/204, 211, 212, 206; 301/37 R, 63 R, 64 R, 645, 65**

D. 200,307 2/1965 Reid D12/212
D. 267,402 12/1982 Schinella D12/211

Primary Examiner—James M. Gandy
Attorney, Agent, or Firm—Herbert Furman

[57] **CLAIM**

The ornamental design for a vehicle wheel segment, as shown.

DESCRIPTION

FIG. 1 is a front elevational view of a vehicle wheel segment showing my new design;
FIG. 2 is a sectional view taken along line 2—2 of FIG. 1;
FIG. 3 is an enlarged fragmentary sectional view taken along line 3—3 of FIG. 2;
FIG. 4 is an enlarged fragmentary sectional view taken along line 4—4 of FIG. 2; and
FIG. 5 is an enlarged fragmentary sectional view taken along line 5—5 of FIG. 2.

[56] **References Cited**

U.S. PATENT DOCUMENTS

D. 172,239 5/1954 Mason D12/211
D. 175,855 10/1955 Reid D12/211
D. 183,326 8/1958 Ross D12/212
D. 190,372 5/1961 Reynolds D12/212

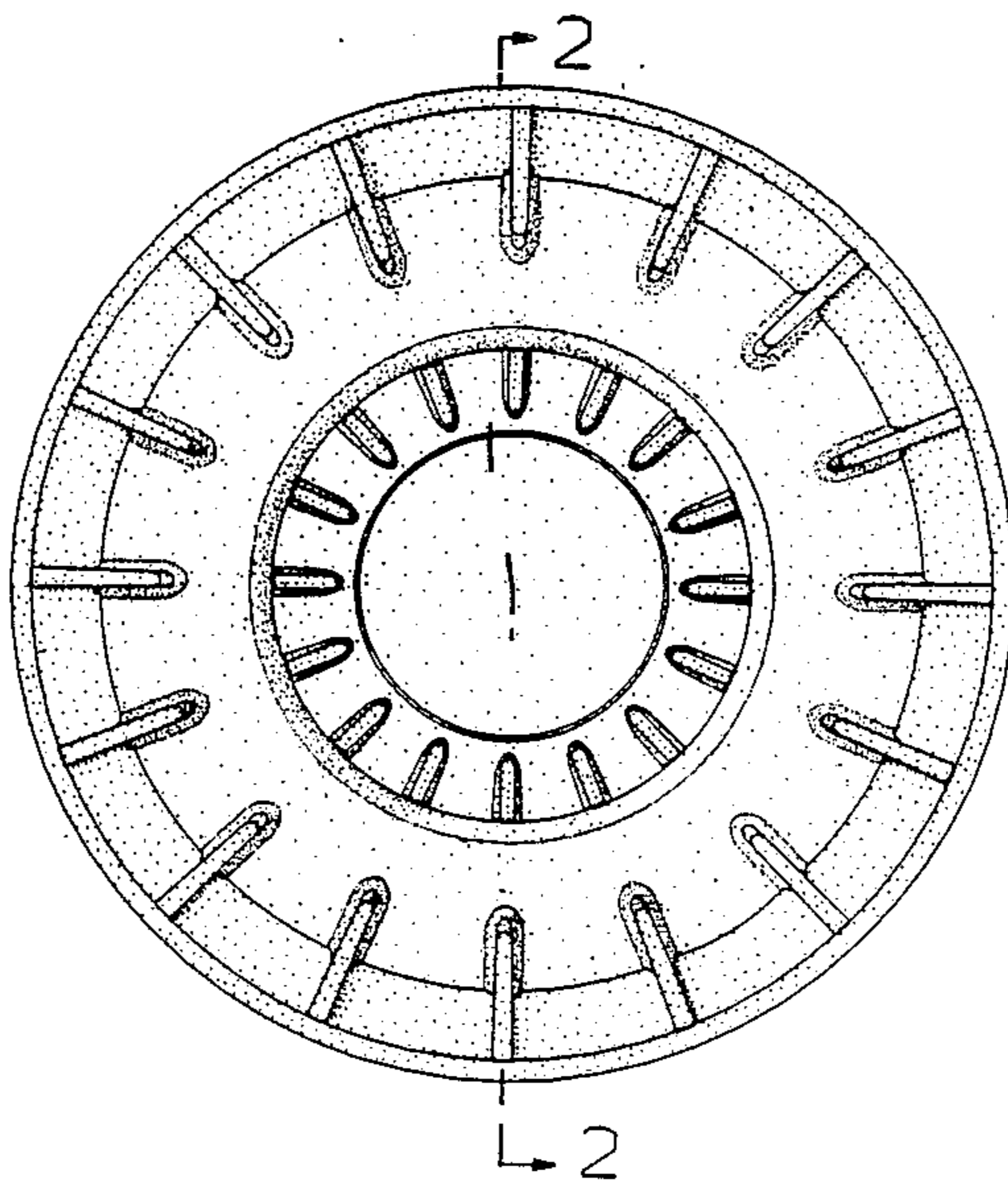

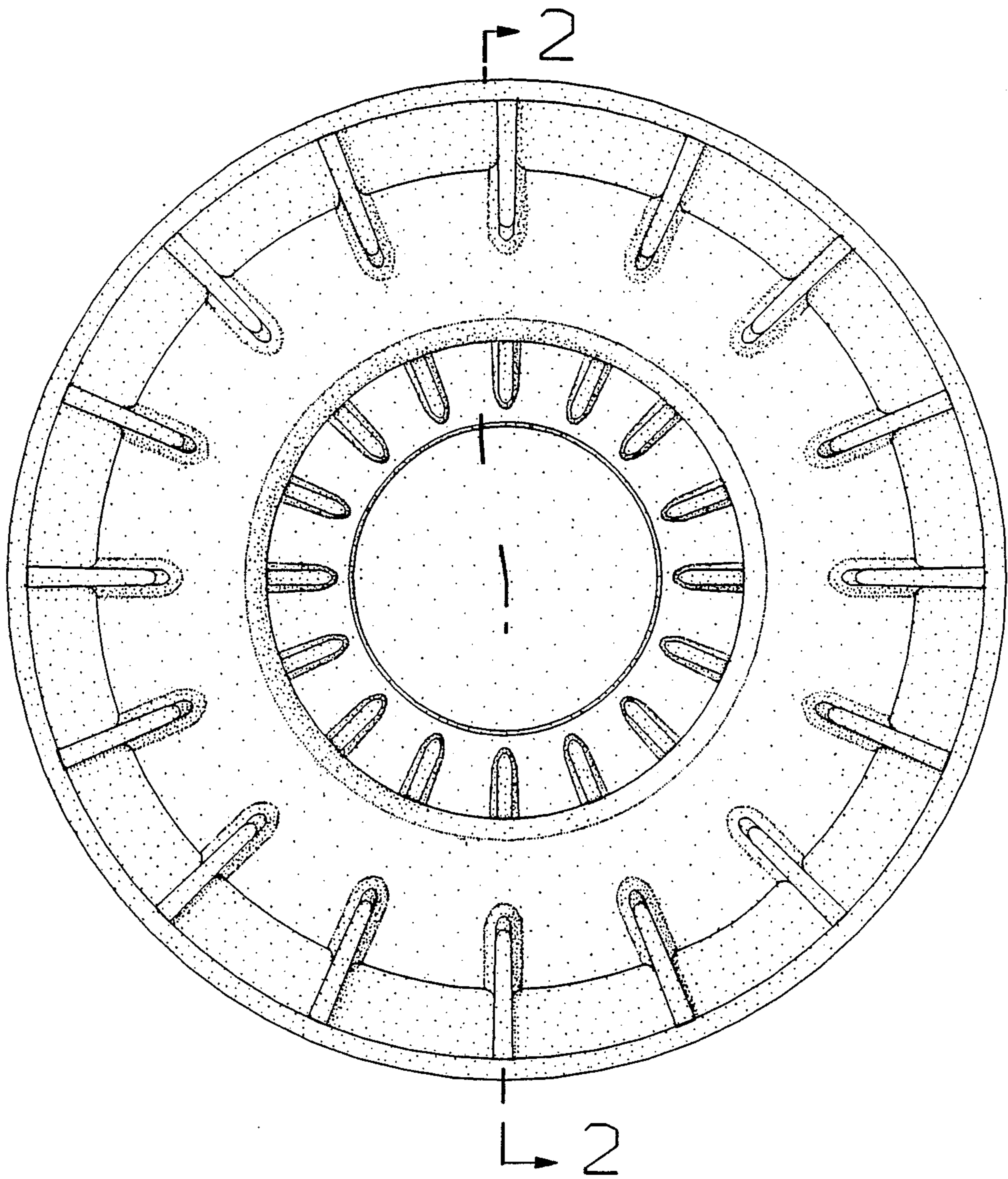

FIG. 1

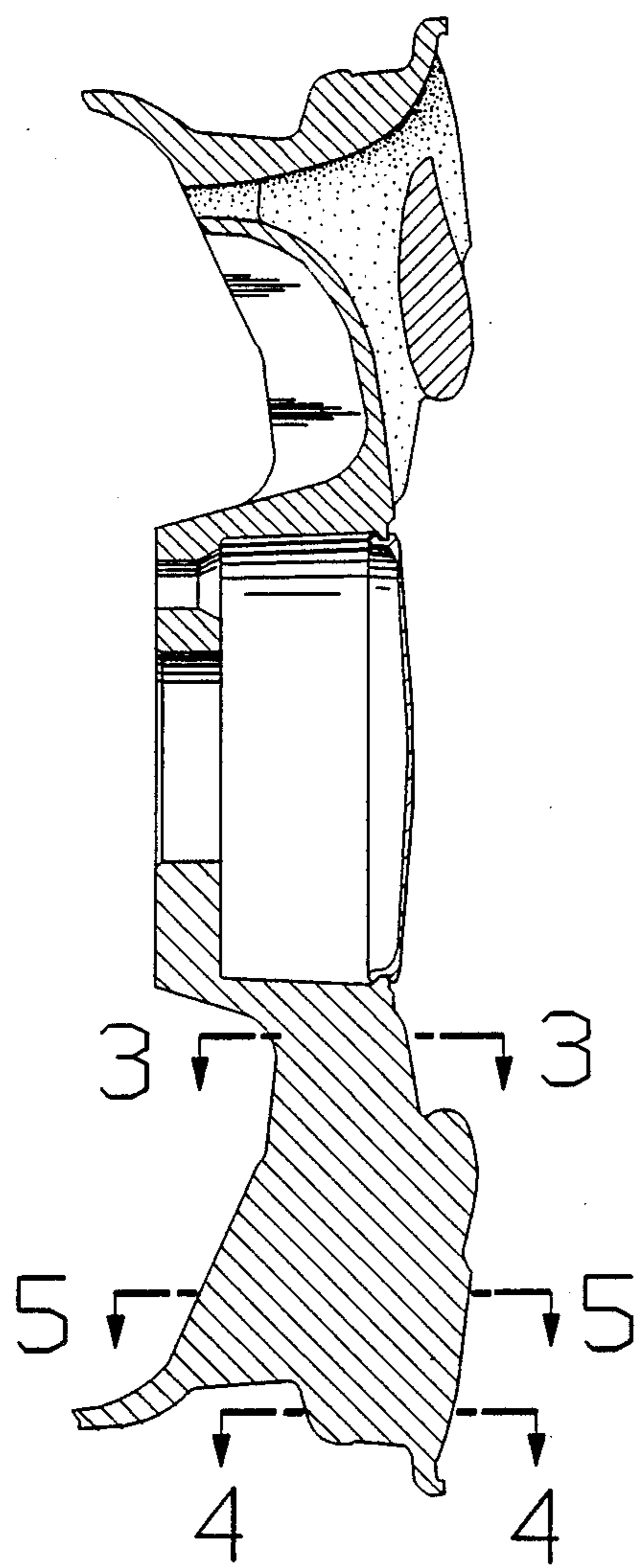

FIG. 2

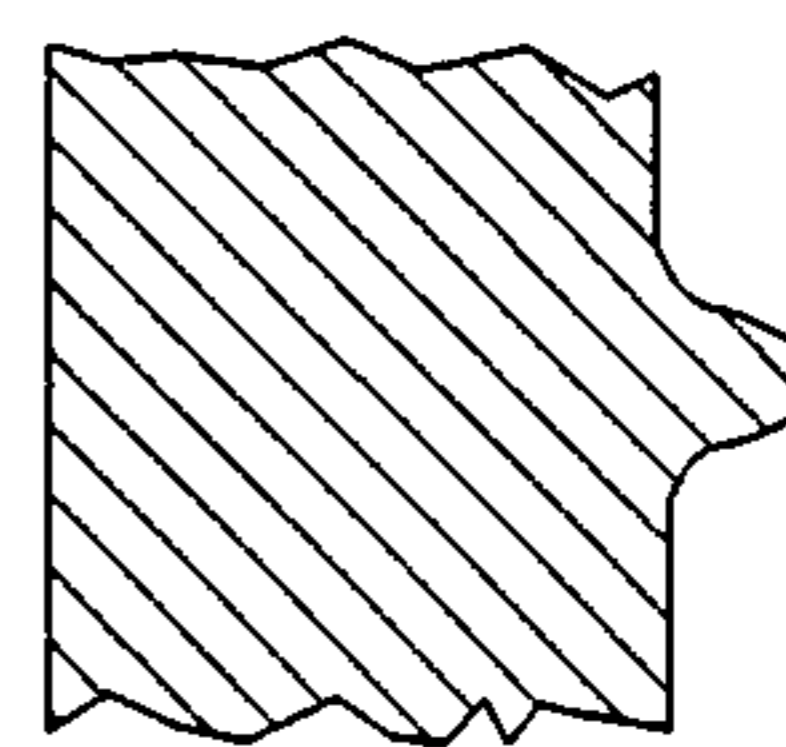

FIG. 3

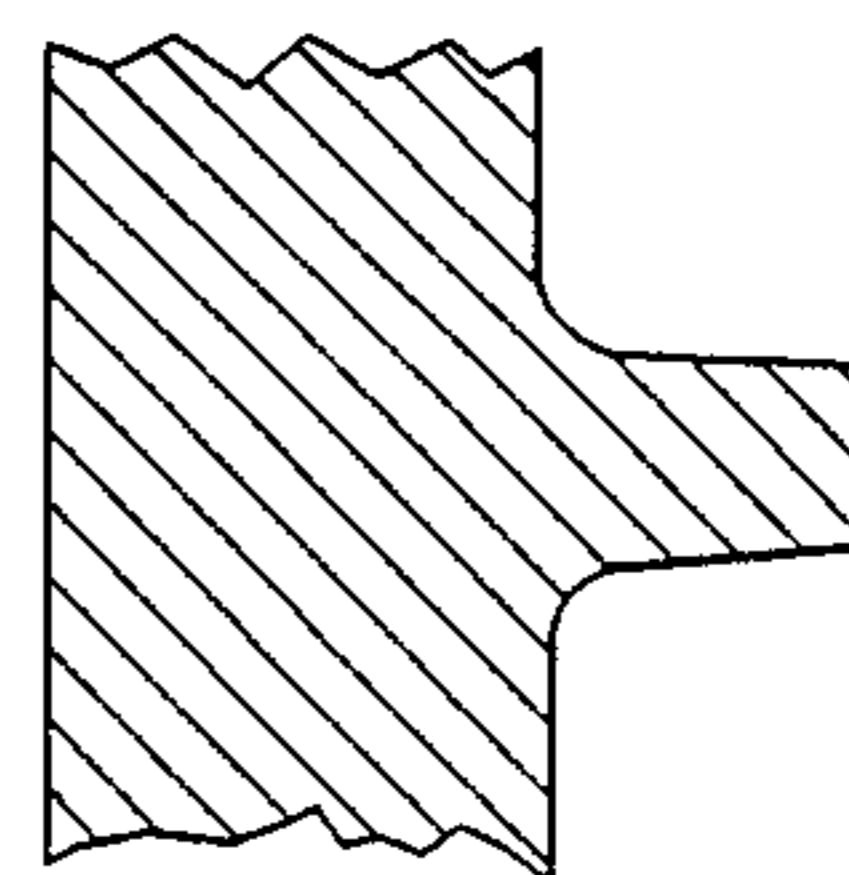

FIG. 4

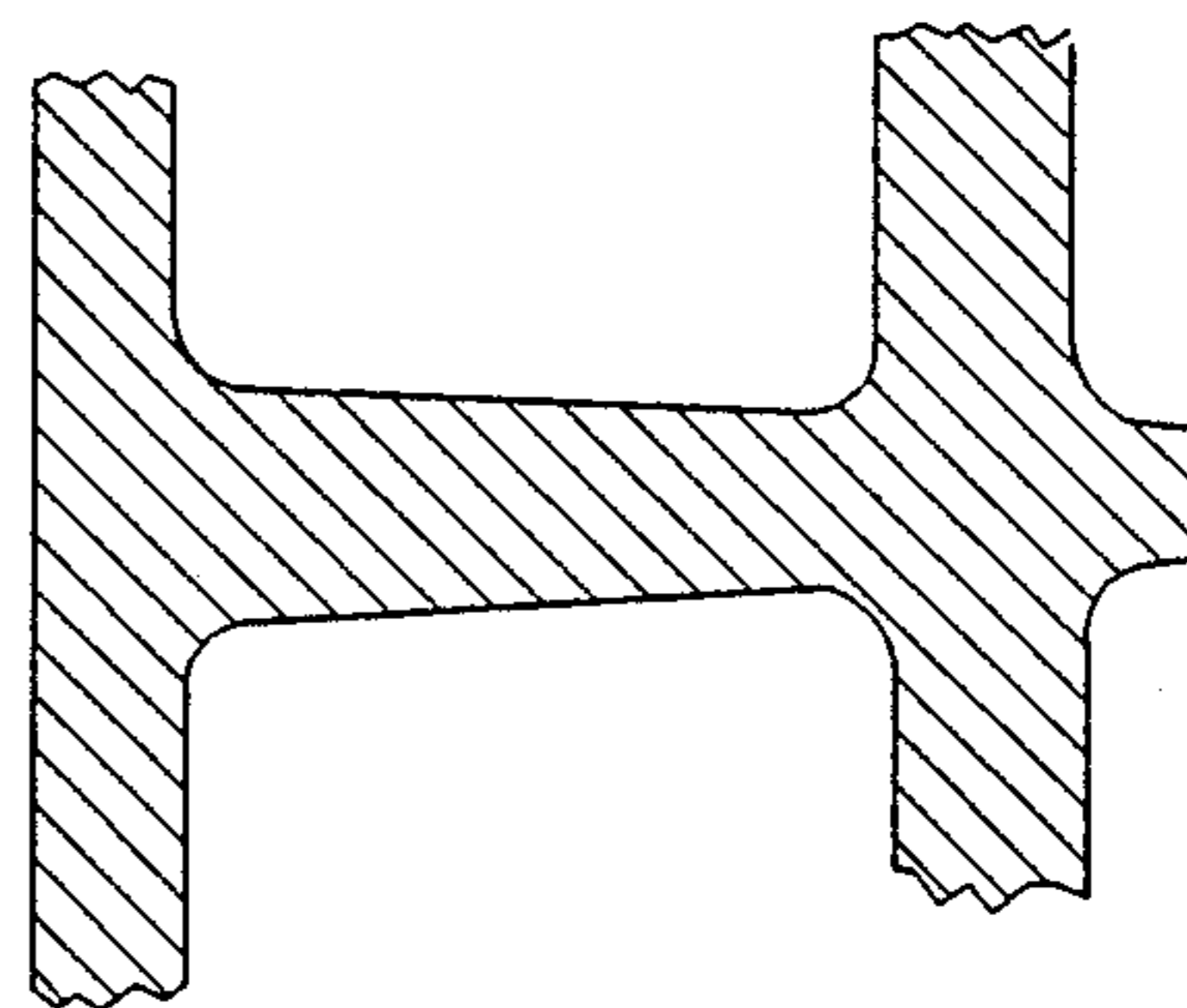

FIG. 5