

[54] **TRICYCLE**

- [75] **Inventor: Steven Goldmeier, Old Bethpage, N.Y.**  
[73] **Assignee: Rand International, Farmingdale, N.Y.**  
[\*\*] **Term: 14 Years**  
[21] **Appl. No.: 149,065**  
[22] **Filed: Jan. 26, 1988**  
[52] **U.S. Cl. .... D12/112**  
[58] **Field of Search ..... D12/112, 113; 280/282, 280/202, 204**

[56] **References Cited**

**U.S. PATENT DOCUMENTS**

D. 159,103	6/1950	Smith	.....	D12/113
D. 224,254	7/1972	Hill	.....	D12/112
D. 231,209	4/1979	Williams	.....	D12/112
3,152,838	10/1964	Morehead	.....	D12/112
3,827,519	8/1974	Snider	.....	180/217

**OTHER PUBLICATIONS**

American Bicyclist & Motorcyclist, Feb. 1987, p. 76, tricycle with doll carrier.  
American Bicyclist & Motorcyclist, Aug. 1987, p. 68, Gomier Tricycle with Carrier.  
*Primary Examiner*—James M. Gandy  
*Assistant Examiner*—Melody Brown  
*Attorney, Agent, or Firm*—Kuhn and Muller

[57] **CLAIM**

The ornamental design for a tricycle, as shown and described.

**DESCRIPTION**

FIG. 1 is a perspective view of a tricycle showing my new design;  
FIG. 2 is a right side elevational view thereof, it being understood that the left side is a mirror image of that shown herein;  
FIG. 3 is a rear elevational view thereof;  
FIG. 4 is a front elevational view thereof; and  
FIG. 5 is a top plan view thereof.

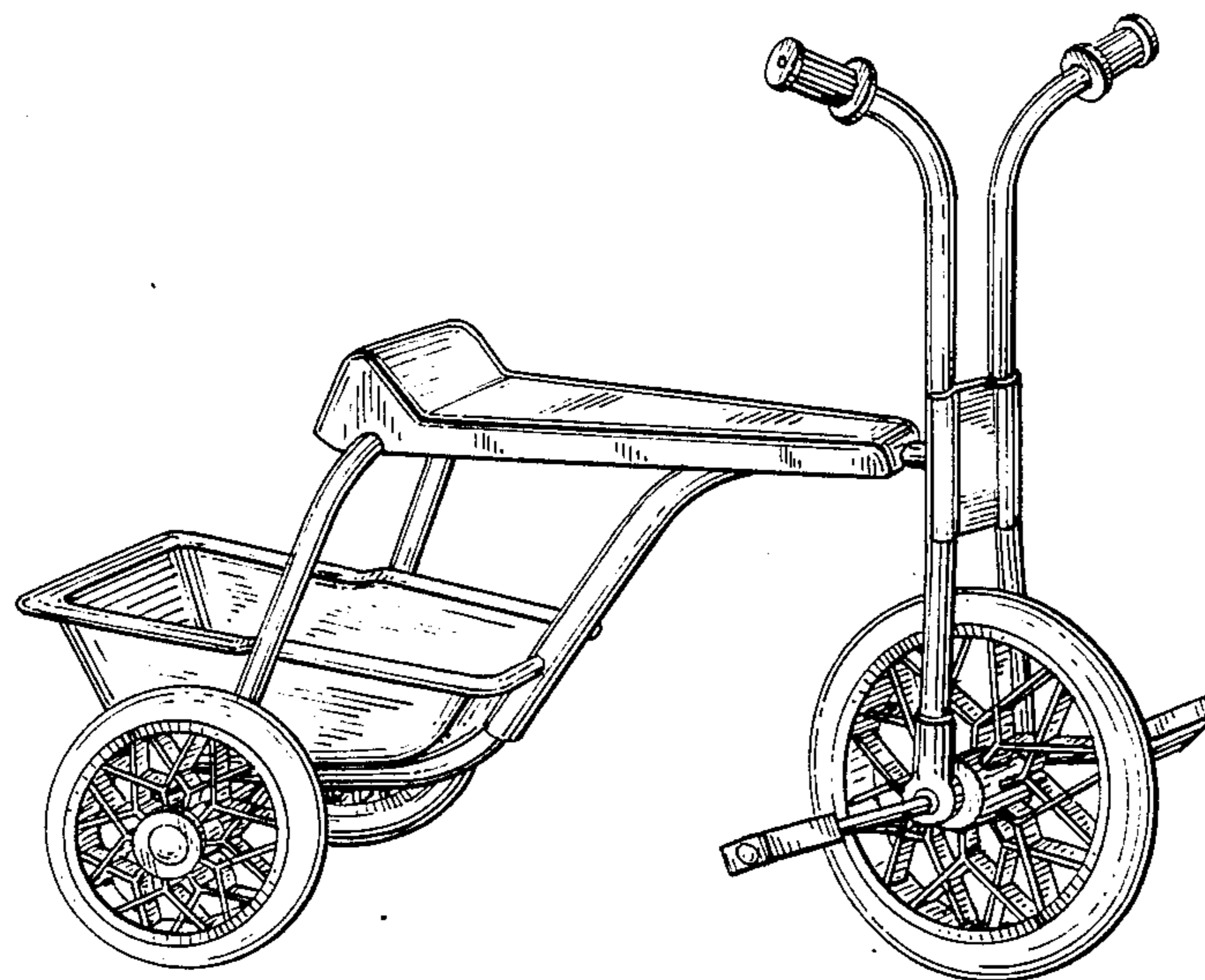

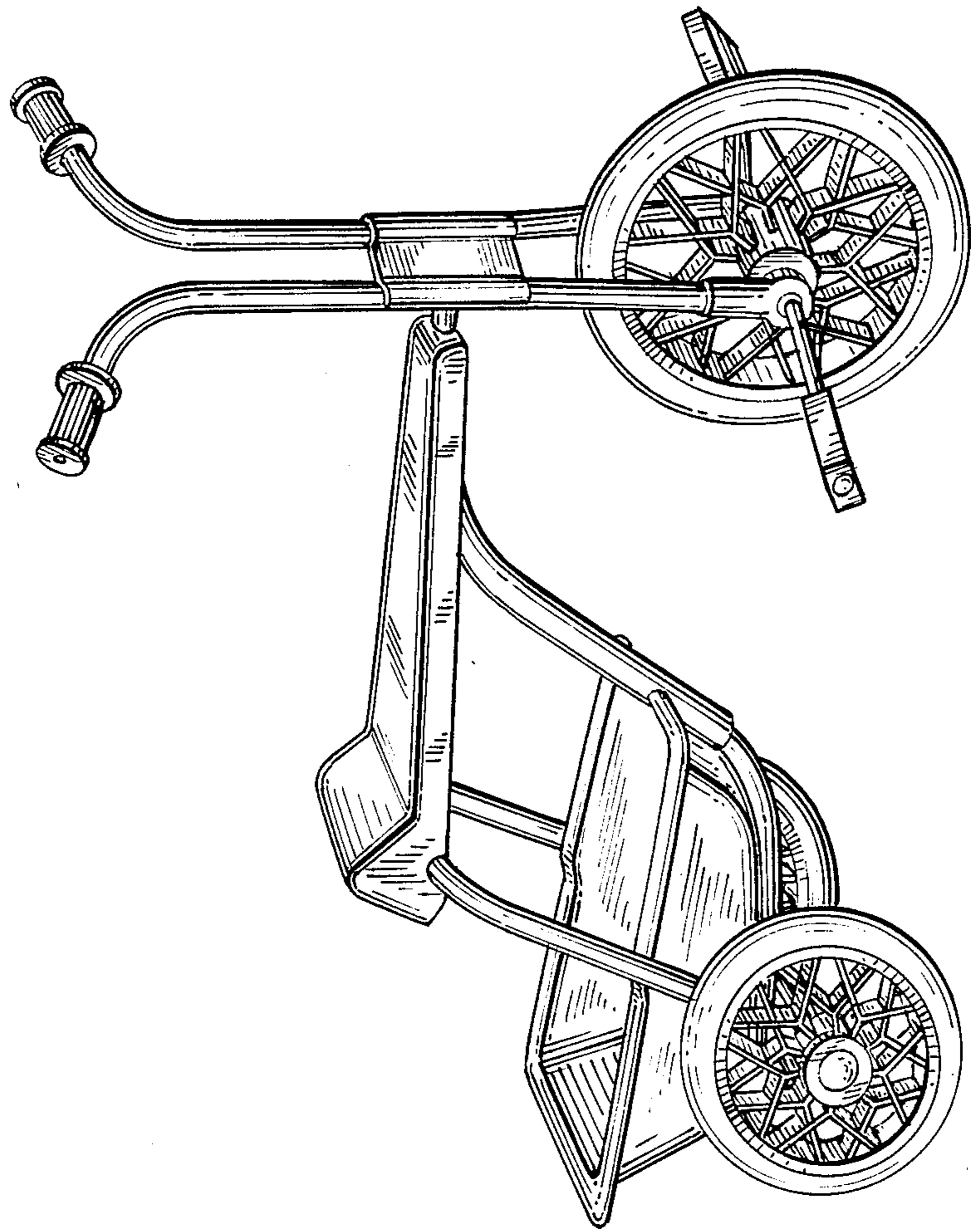

FIG. 1

FIG. 3

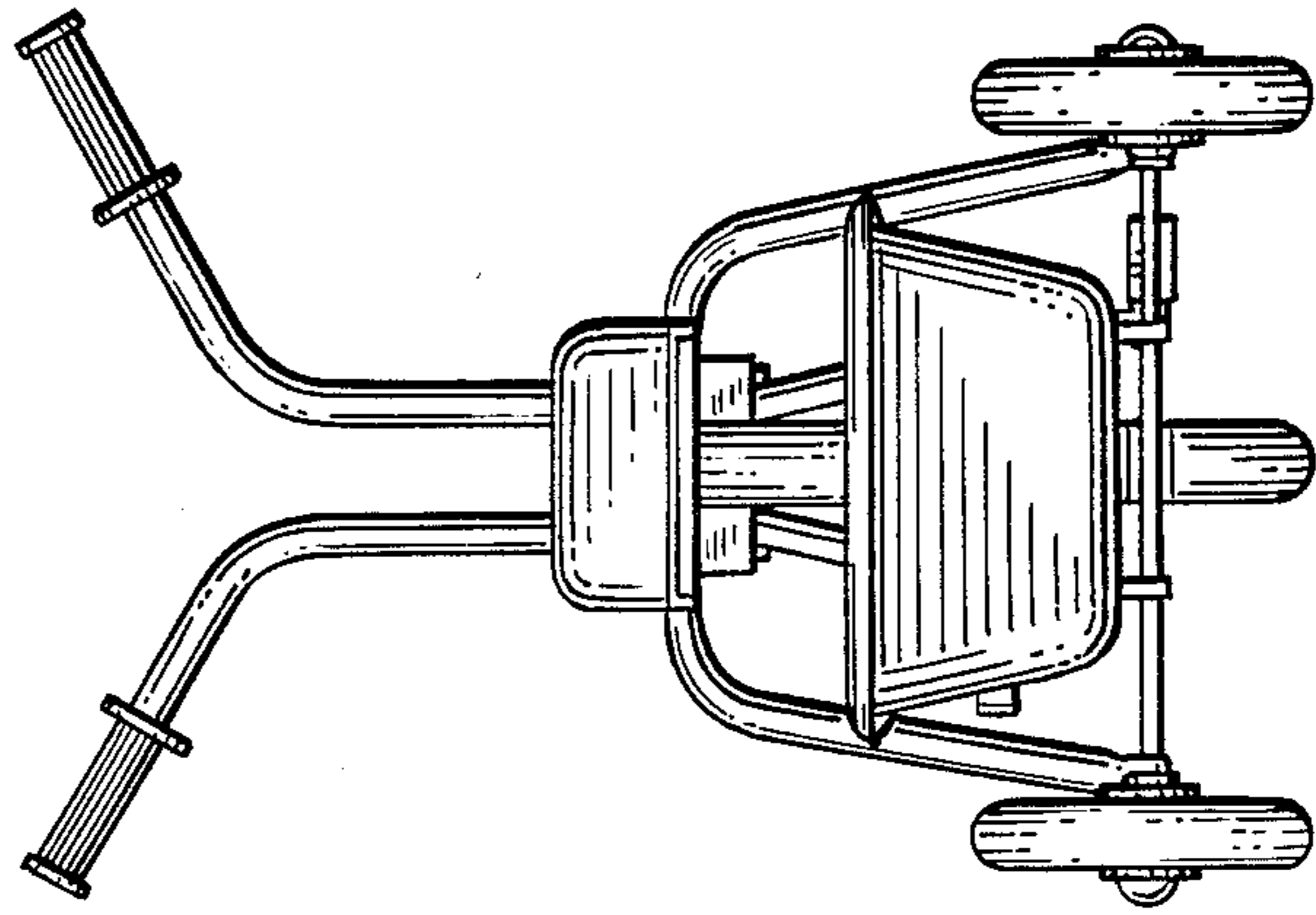
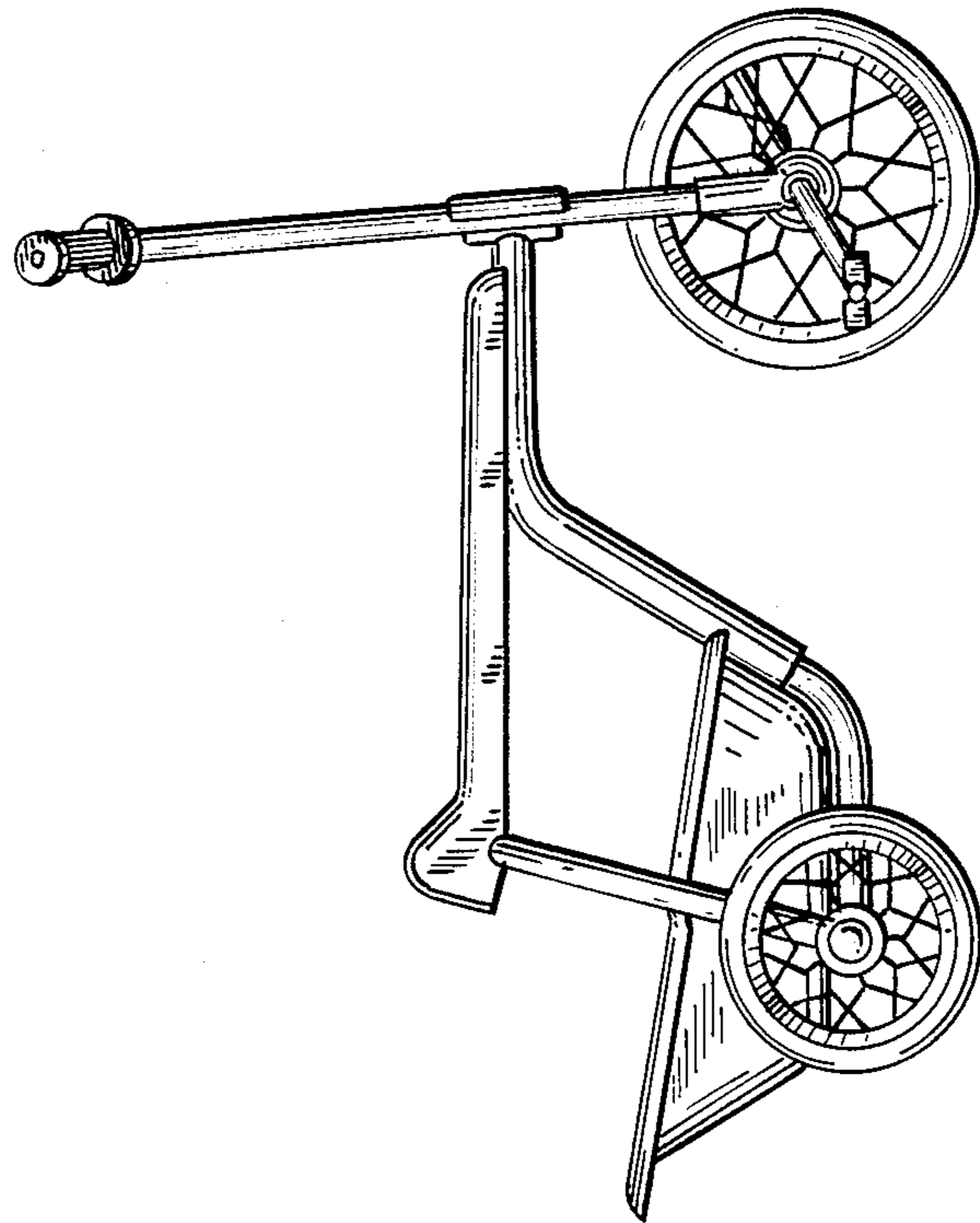

FIG. 2



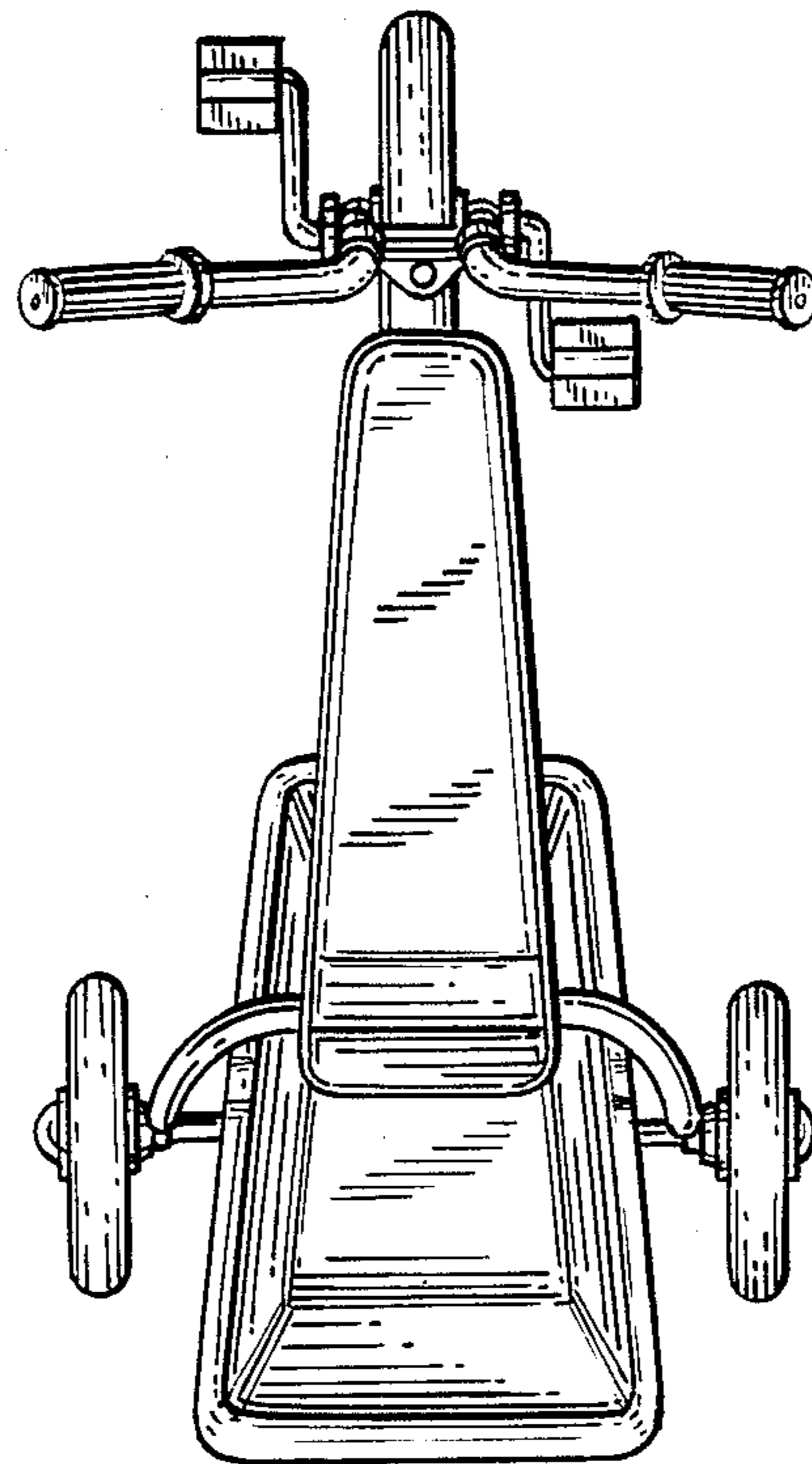

FIG. 5

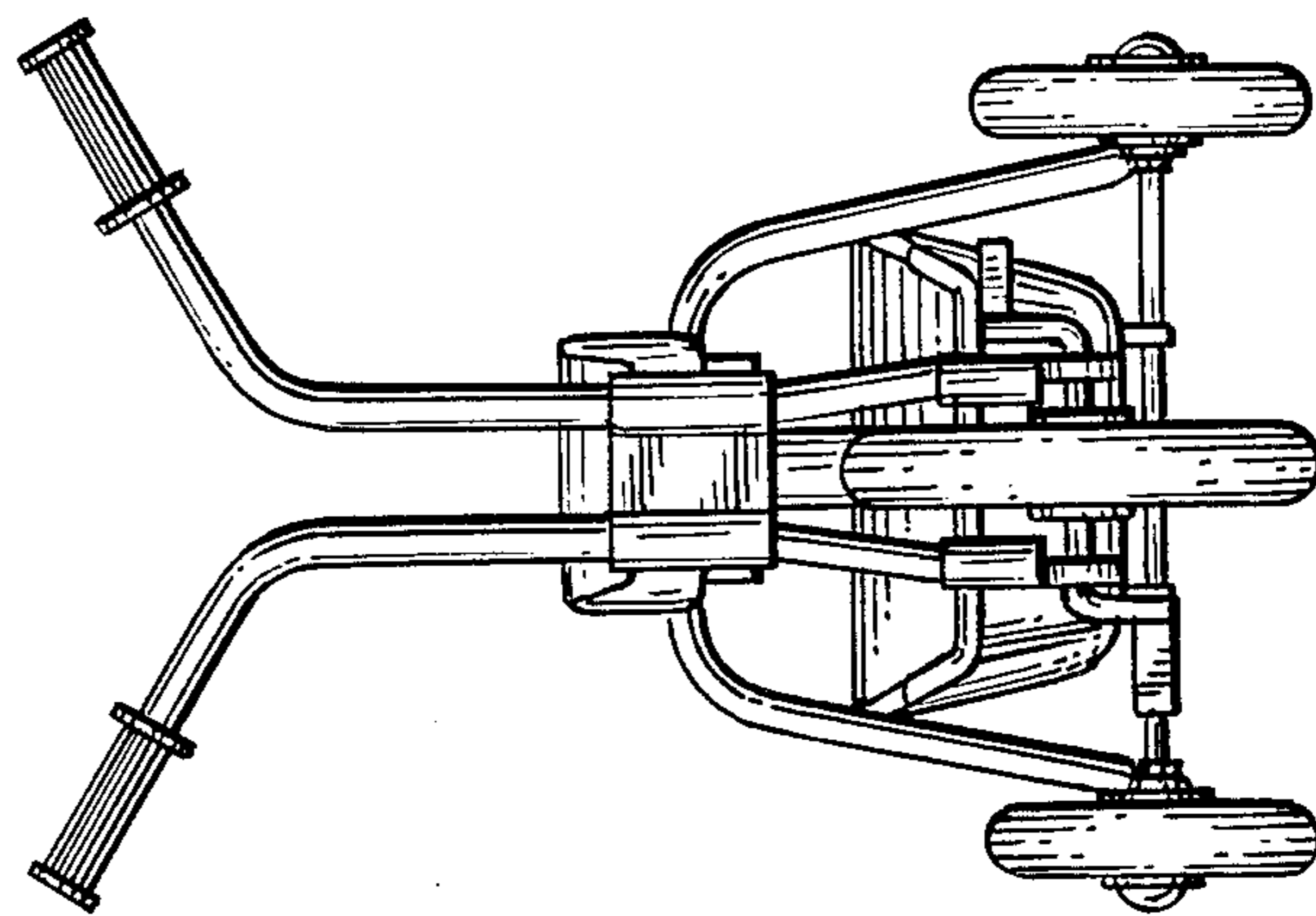

FIG. 4