

[54] COMBINED CONTAINER AND COMPARTMENT FOR HOLDING COOLANTS

[76] Inventor: Walter F. Carty, 654 School St., Lowell, Mass. 01852

[**] Term: 14 Years

[21] Appl. No.: 142,240

[22] Filed: Jan. 11, 1988

[52] U.S. Cl. D7/605; D7/533

[58] Field of Search D7/70, 77, 6, 9; D9/455; 220/94 A, 85 H; 215/100.5

[56] References Cited

U.S. PATENT DOCUMENTS

D. 287,322 12/1986 Martin D7/9
3,279,638 10/1966 Merry 215/100.5

Primary Examiner—Bernard Ansher
Assistant Examiner—Terry A. Pfeffer

Attorney, Agent, or Firm—Pearson & Pearson

[57] CLAIM

The ornamental design for a combined container and compartment for holding coolants, as shown and described.

DESCRIPTION

FIG. 1 is a top right side perspective view of a combined container and compartment for holding coolants showing my new design;

FIG. 2 is a right side elevational view thereof with a portion cut away for clarity of illustration;

FIG. 3 is a left side elevational view thereof with a portion cut away for clarity of illustration;

FIG. 4 is a cross-sectional view thereof taken along line 4—4 of FIG. 1;

FIG. 5 is a top plan view thereof;

FIG. 6 is a bottom plan view thereof;

FIG. 7 is a front elevational view thereof; and

FIG. 8 is a rear elevational view thereof.

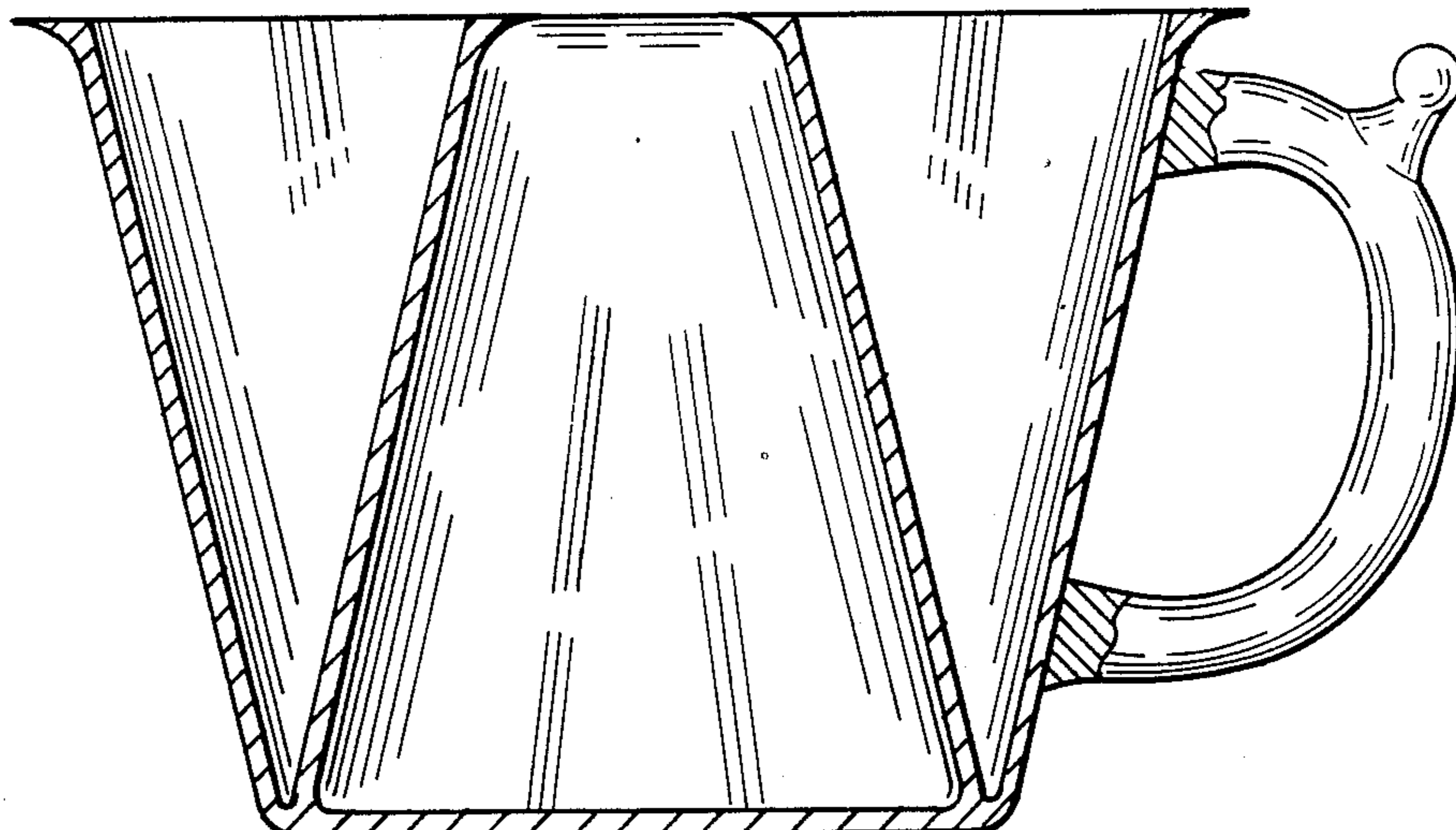
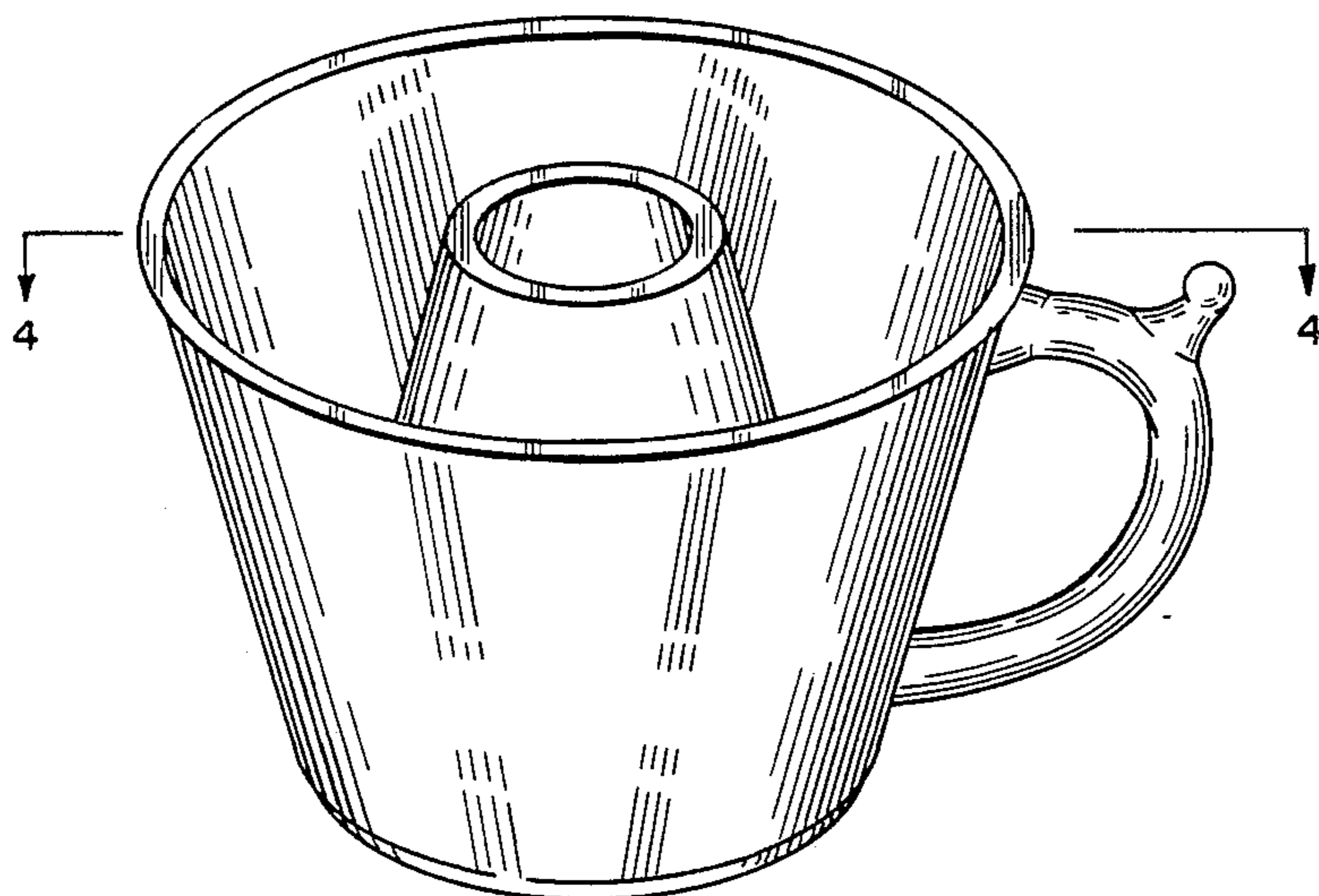

Fig. 1.

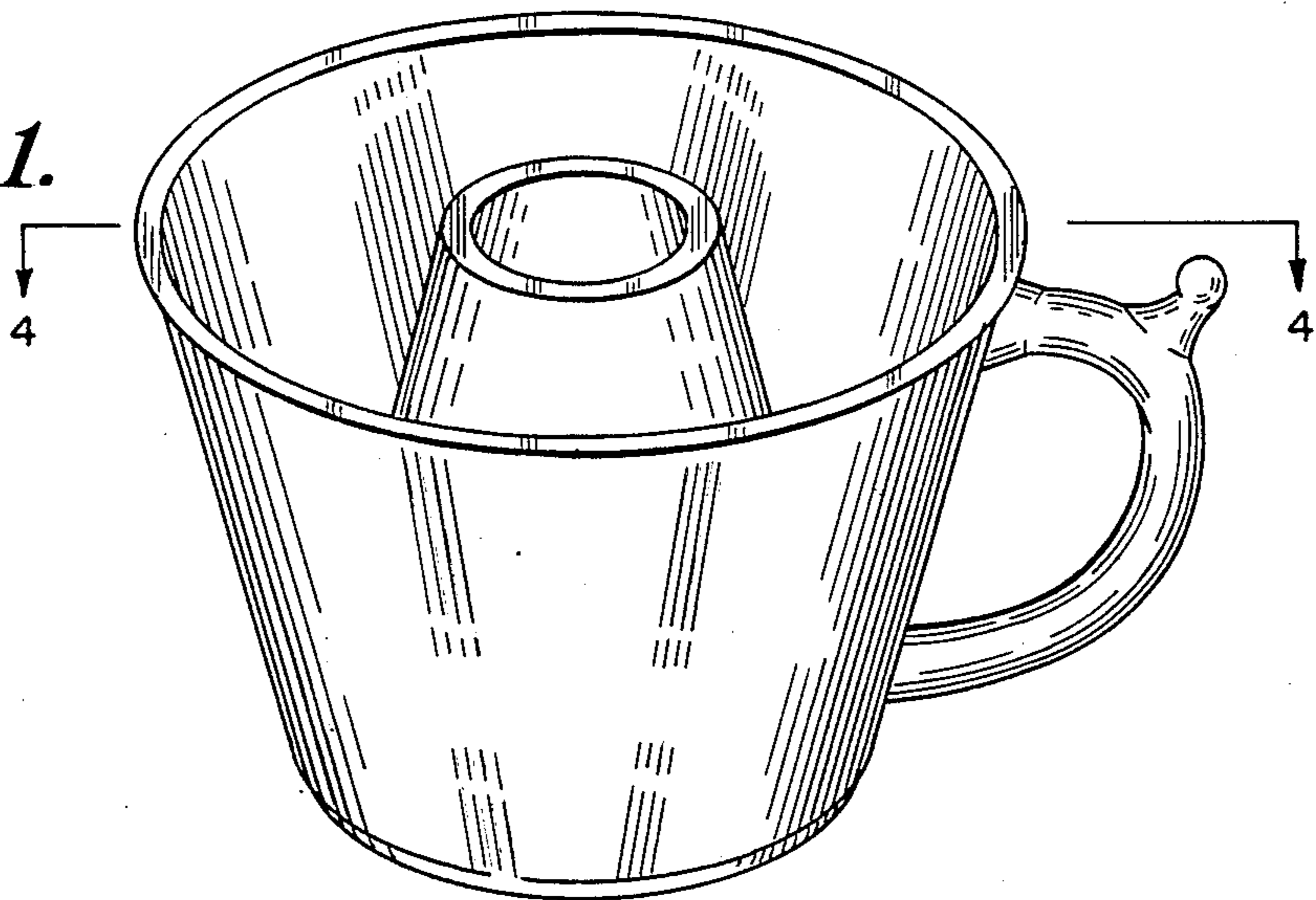

Fig. 2.

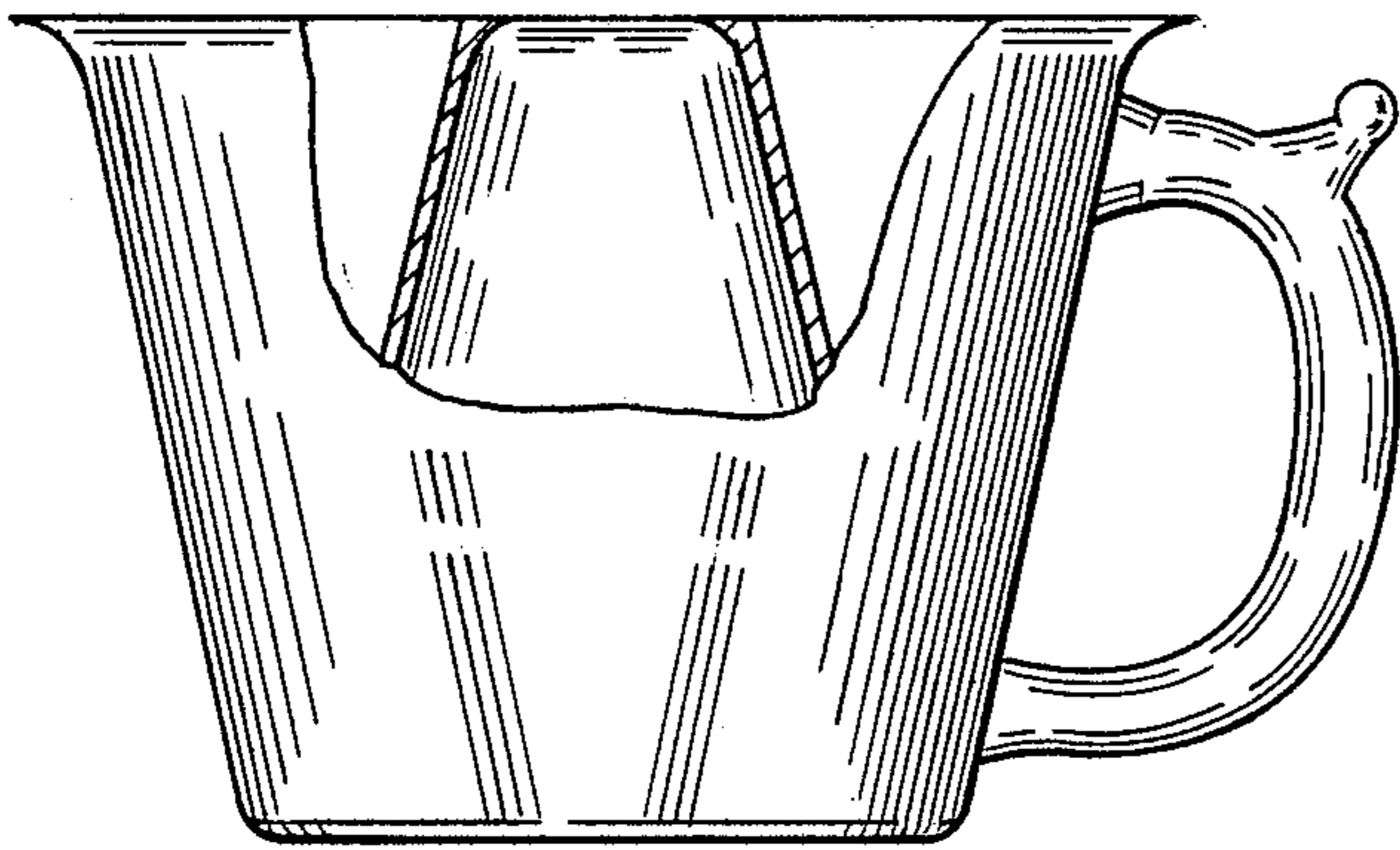

Fig. 3.

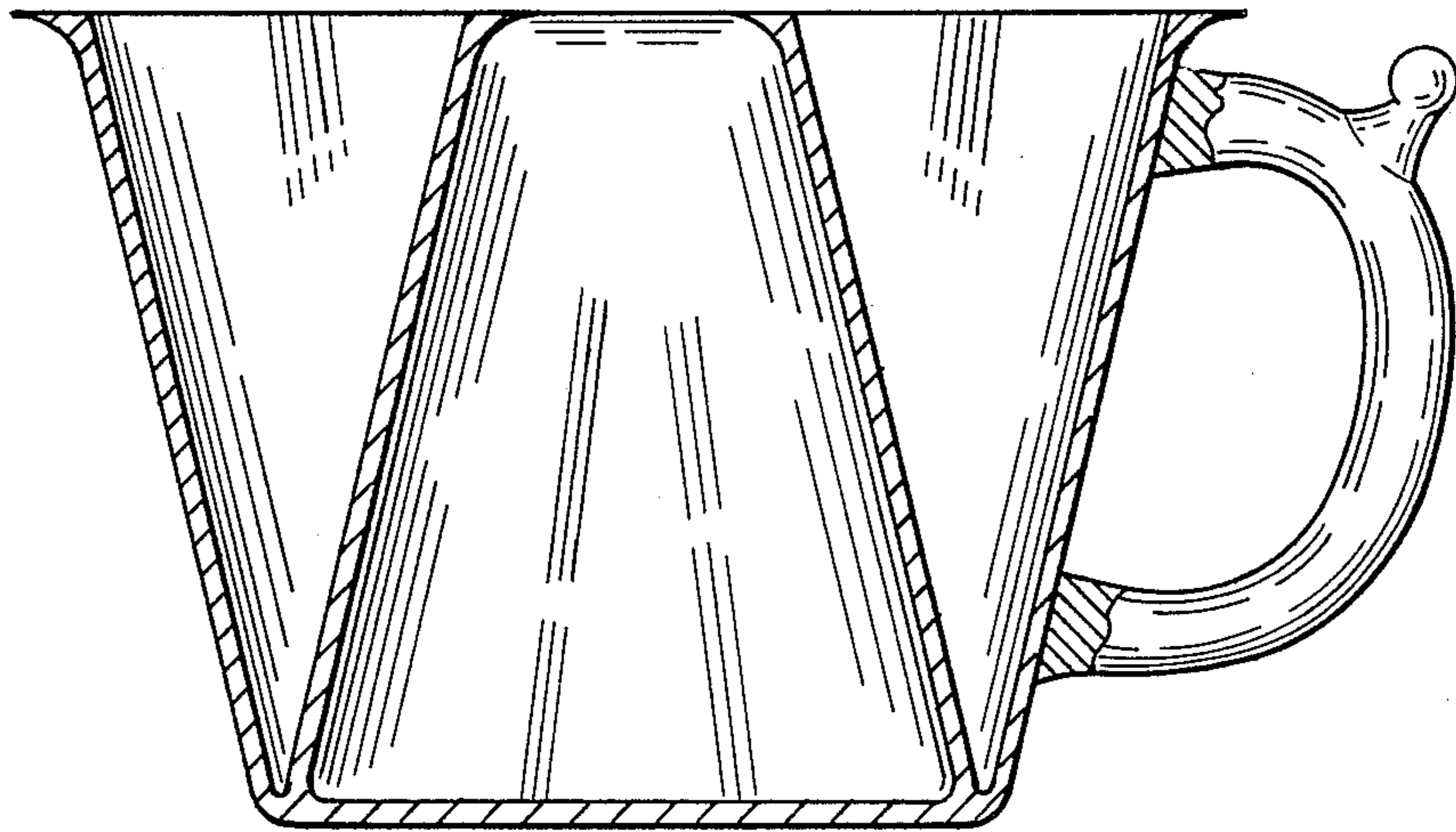
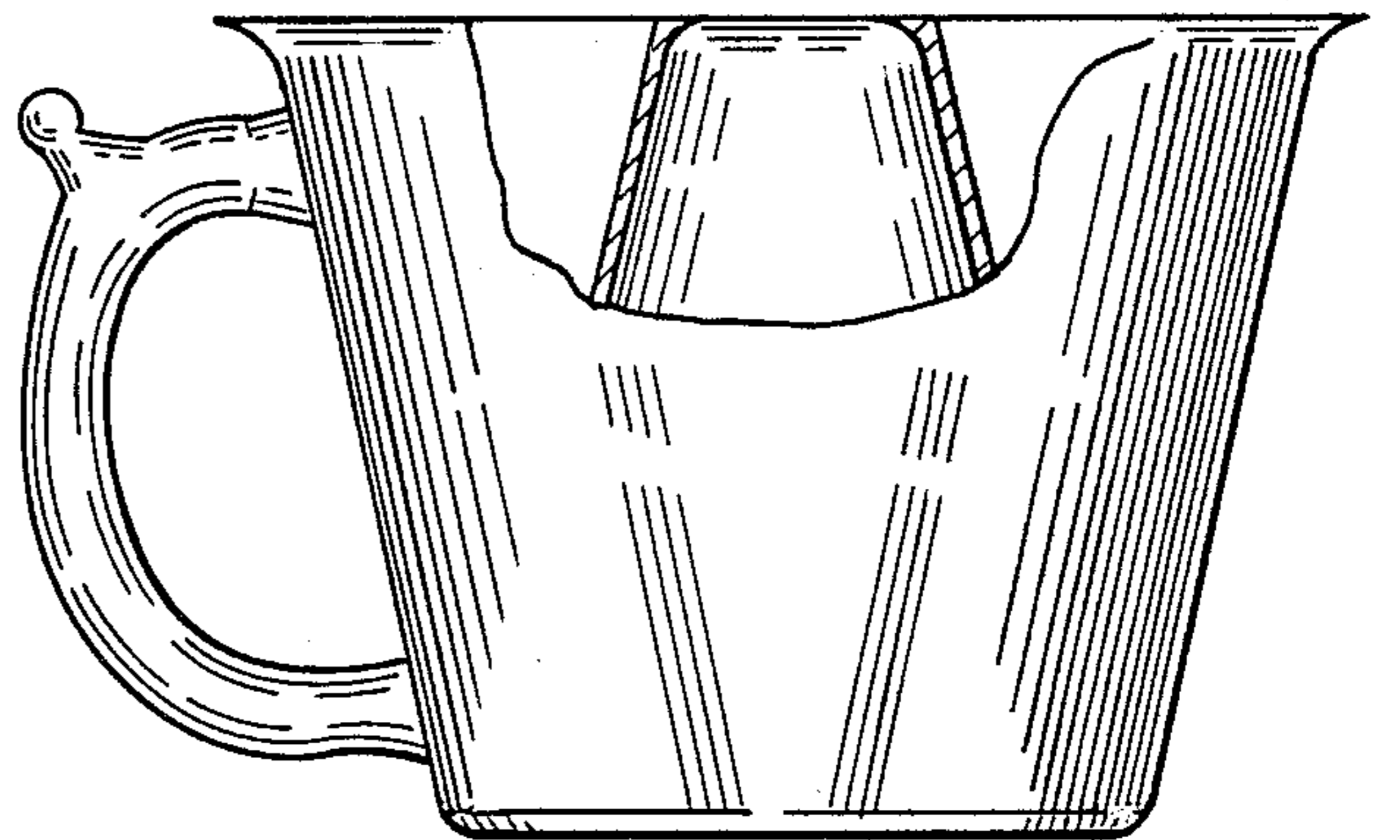

Fig. 4.

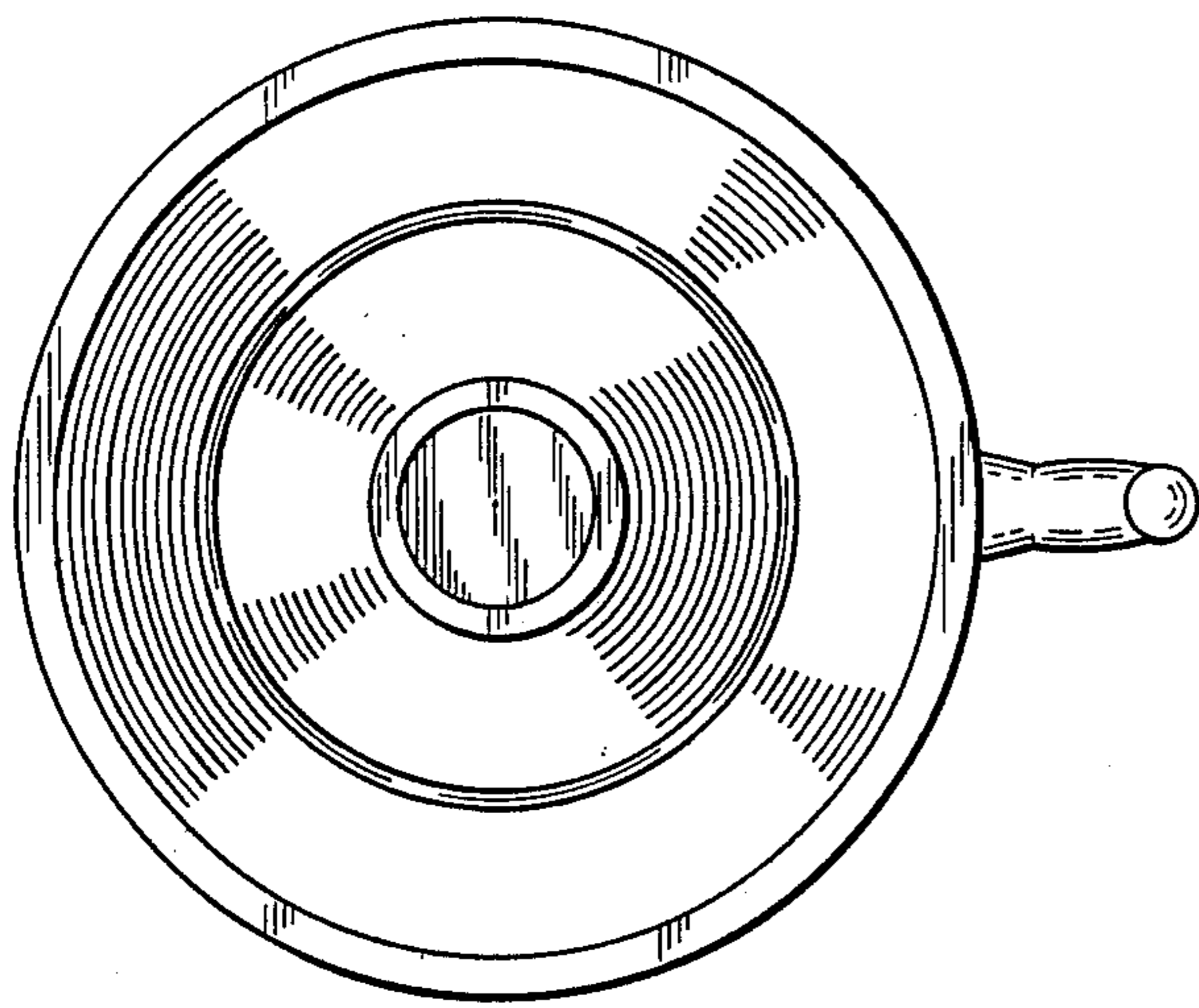

Fig. 5.

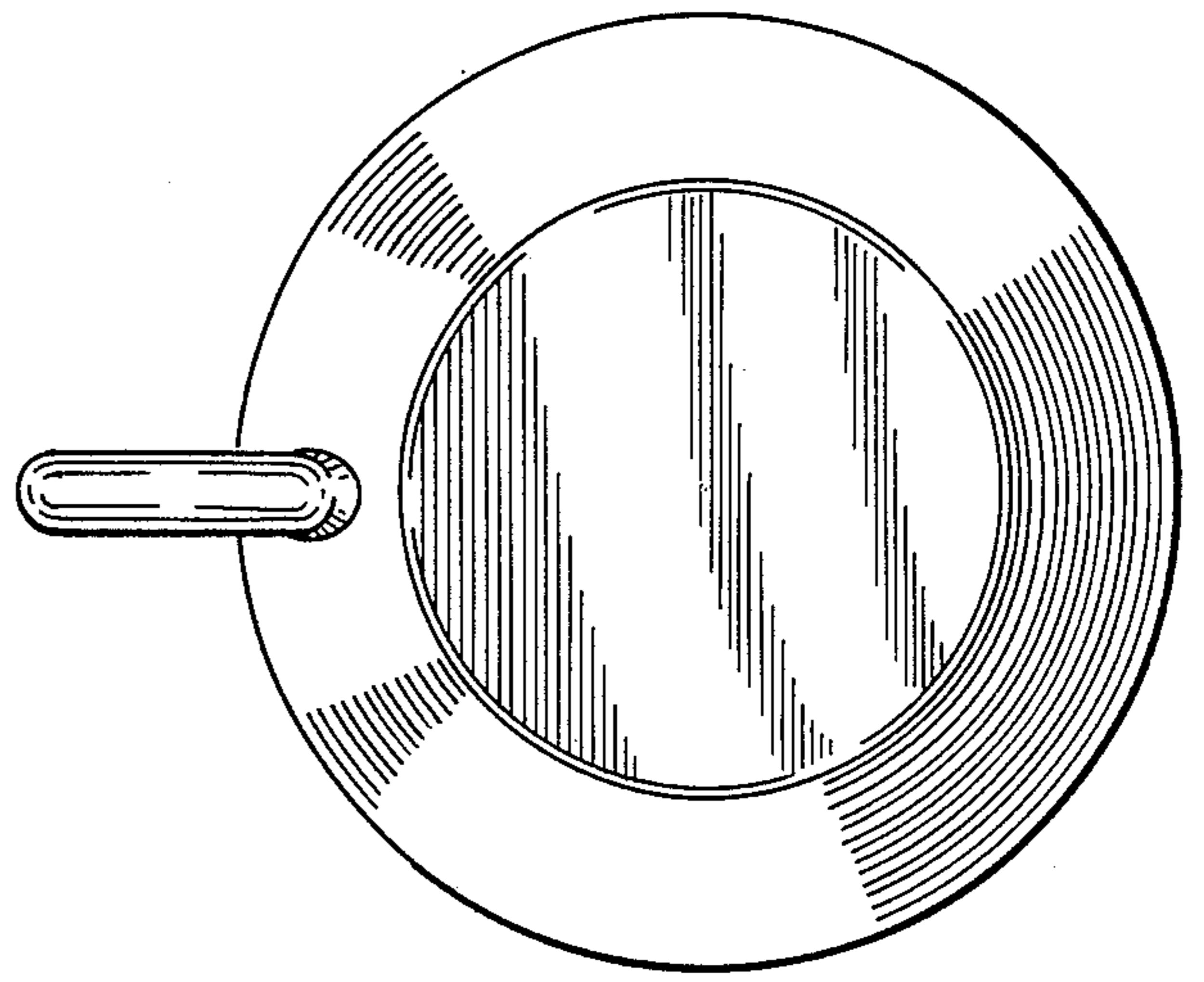

Fig. 6.

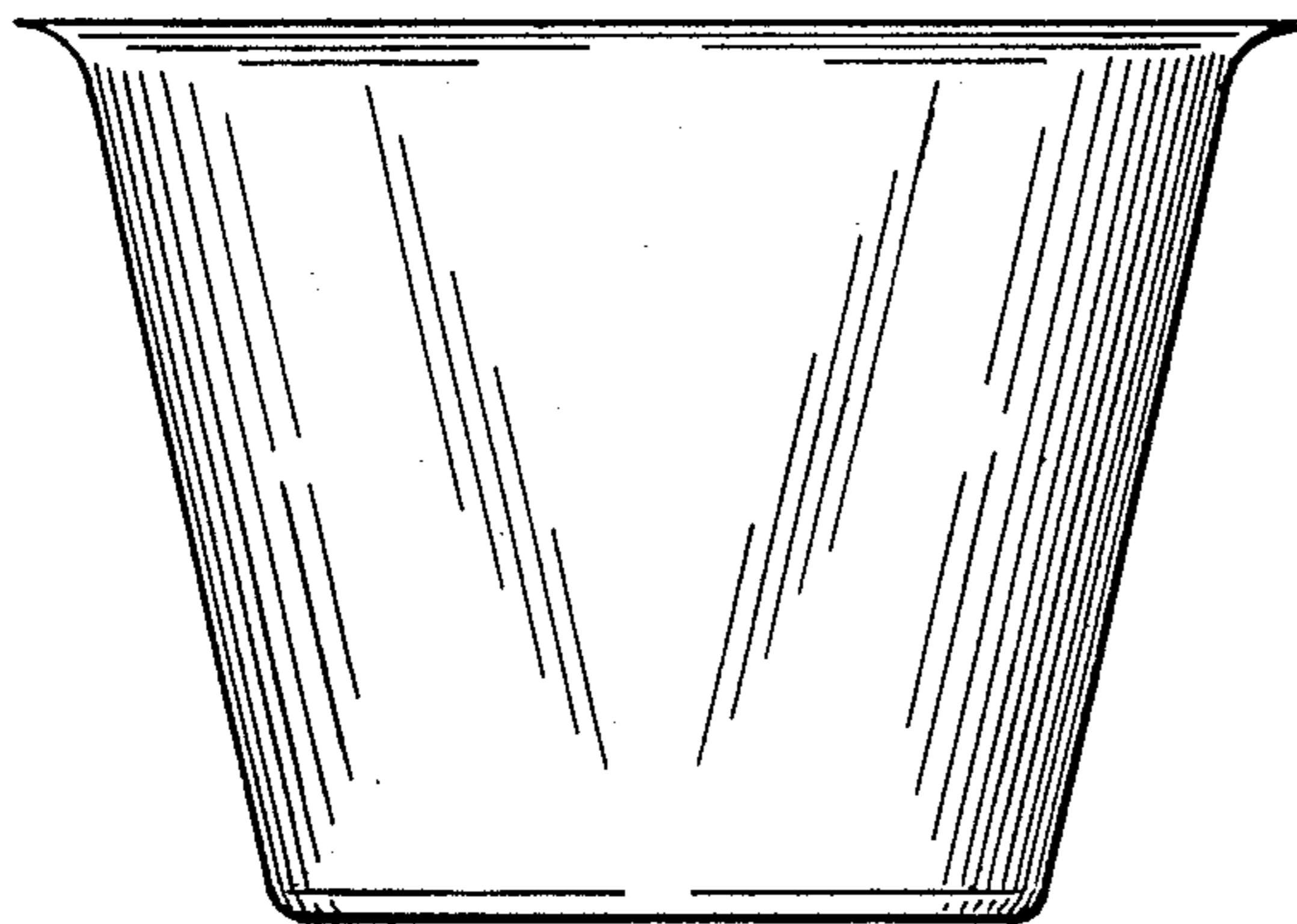

Fig. 7.

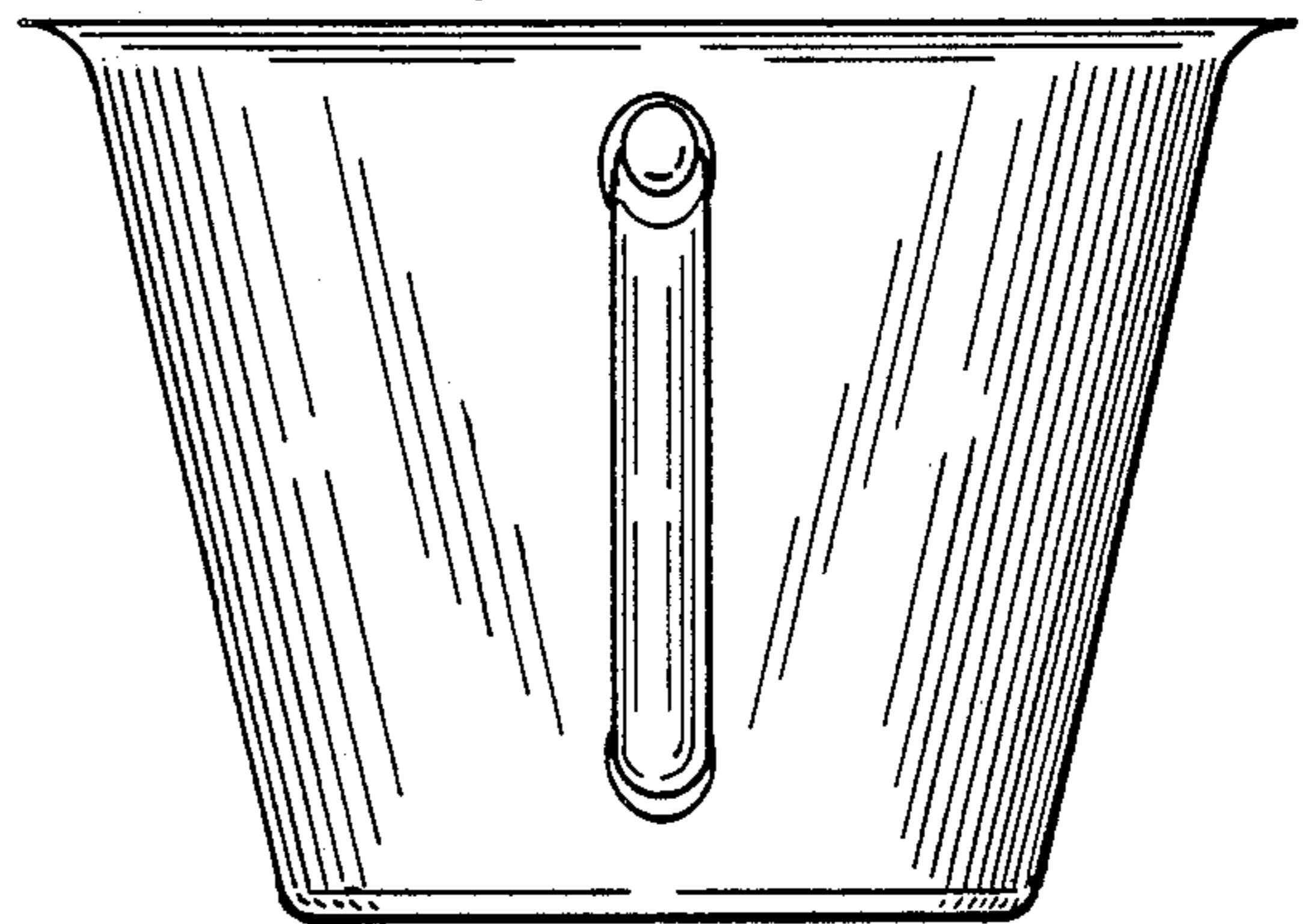

Fig. 8.