

[54] **CYCLIST'S VENTILATED HELMET**
 [75] **Inventor:** Lester V. Broersma, Bellflower, Calif.
 [73] **Assignee:** Bell Bicycles Inc., Norwalk, Calif.
 [**] **Term:** 14 Years
 [21] **Appl. No.:** 109,254
 [22] **Filed:** Oct. 16, 1987
 [52] **U.S. Cl.** D29/12
 [58] **Field of Search** D29/10, 12-19; D2/244, 246; 2/410, 421; 423/425, 9, 10, 431

3,082,428	3/1963	Zbikowski	2/3
3,310,811	3/1967	Iacono, Jr.	2/6
3,496,854	2/1970	Feldmann et al.	98/1
3,783,450	1/1974	O'Connor	2/3 R
3,873,997	4/1975	Gooding	2/3 R
3,925,821	12/1975	Lewicki	2/3 R
4,044,400	8/1977	Lewicki et al.	2/421
4,434,514	3/1984	Sundahl et al.	2/425
4,555,816	12/1985	Broersma	2/425
4,612,675	9/1986	Broersma	2/424
4,622,700	11/1986	Sundahl	2/425
4,627,115	12/1986	Broersma	2/425
4,653,123	3/1987	Broersma	2/425

Primary Examiner—A. Hugo Word
Assistant Examiner—Ruth McInroy
Attorney, Agent, or Firm—William W. Haefliger

[56] **References Cited**

U.S. PATENT DOCUMENTS

D. 265,520	7/1982	Gooding	D29/15
D. 272,769	2/1984	Sundahl et al.	
D. 272,770	2/1984	Sundahl et al.	D29/14
D. 285,980	10/1986	McNabb	D29/12
D. 299,978	2/1989	Chiarella	D29/15
D. 300,070	2/1989	Broersma	D29/15
935,556	9/1909	Smith	
1,347,046	7/1920	McDonough	
2,769,176	11/1956	Grancsay et al.	2/3
2,846,683	8/1958	Dye et al.	2/3
2,991,478	7/1961	Zbikowski	2/3

[57] **CLAIM**

The ornamental design for a cyclist's ventilated helmet, as shown and described.

DESCRIPTION

FIG. 1 is a top plan view of a cyclist's ventilated helmet showing my new design;
 FIG. 2 is a right side elevational view thereof, the left side being a mirror image;
 FIG. 3 is a front elevational view thereof; and
 FIG. 4 is a rear elevational view thereof.

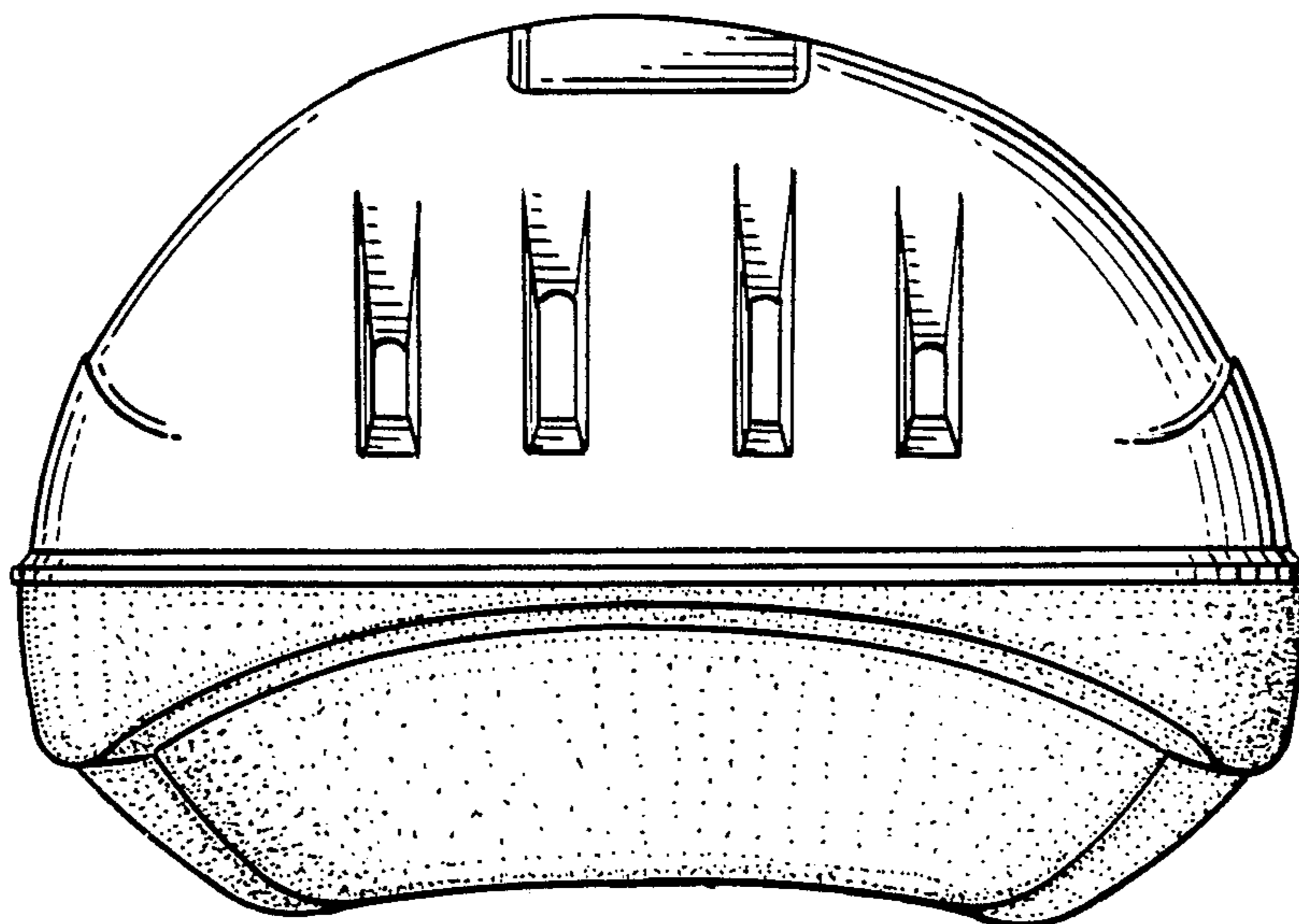
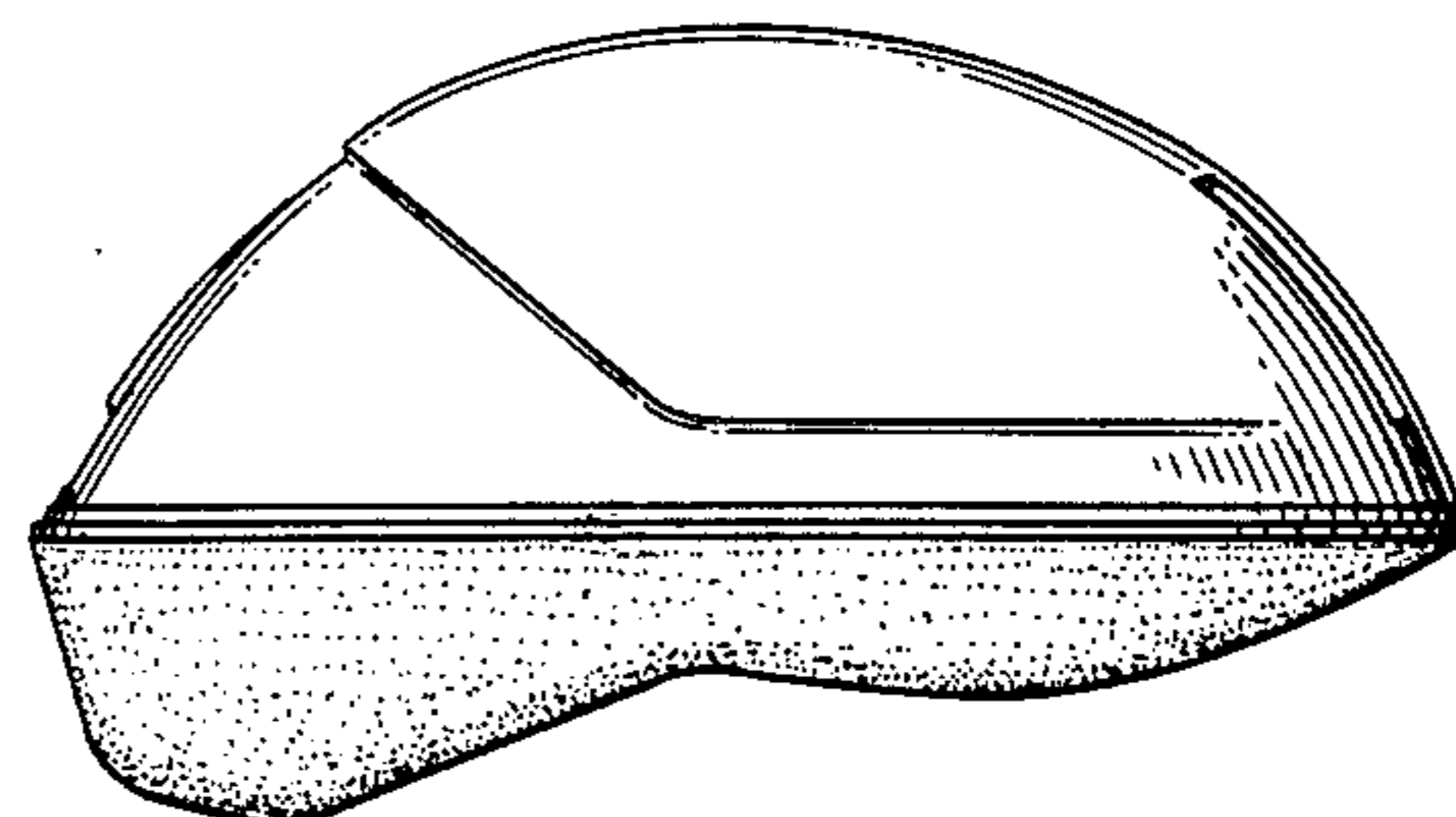
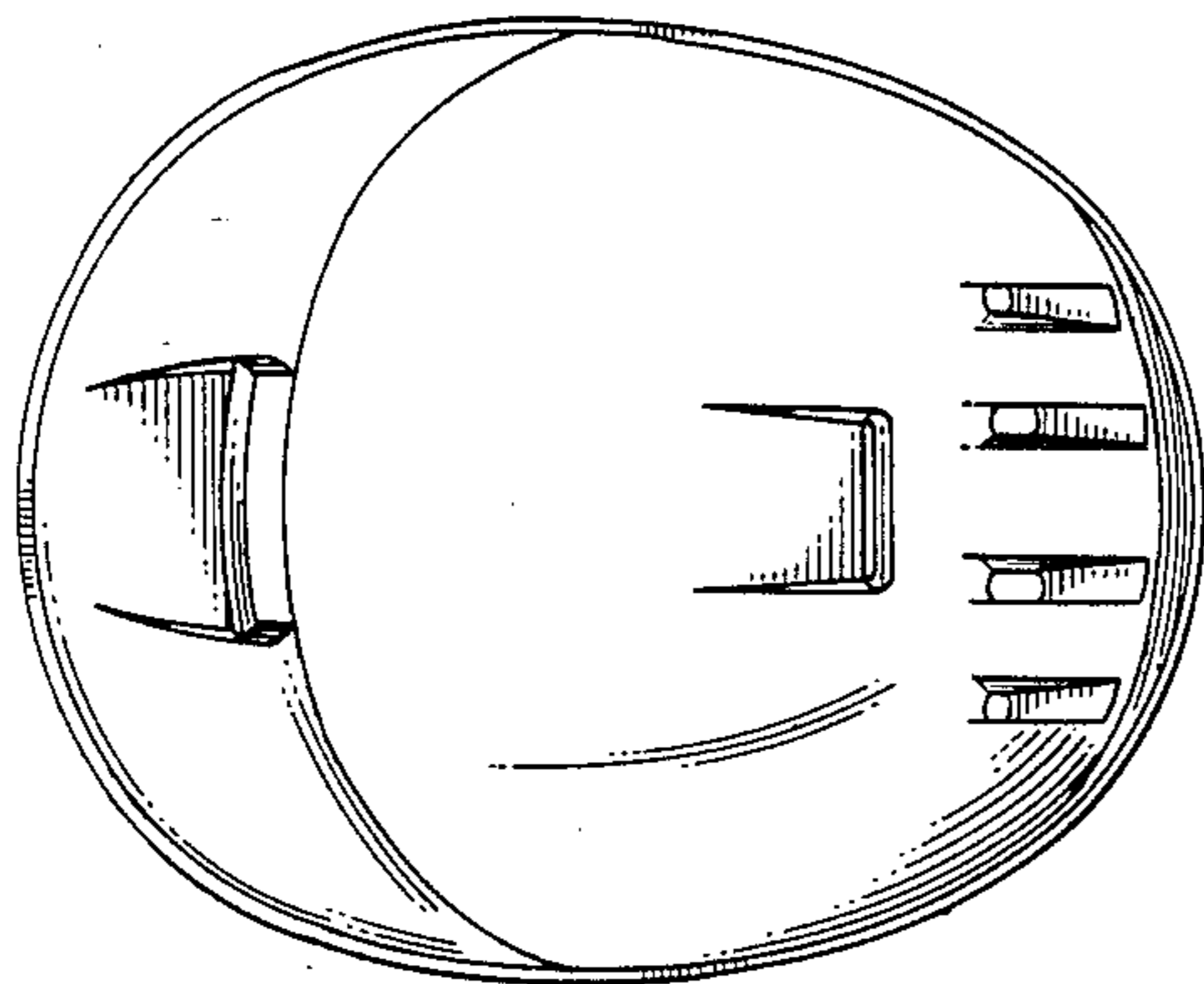

FIG. 1.

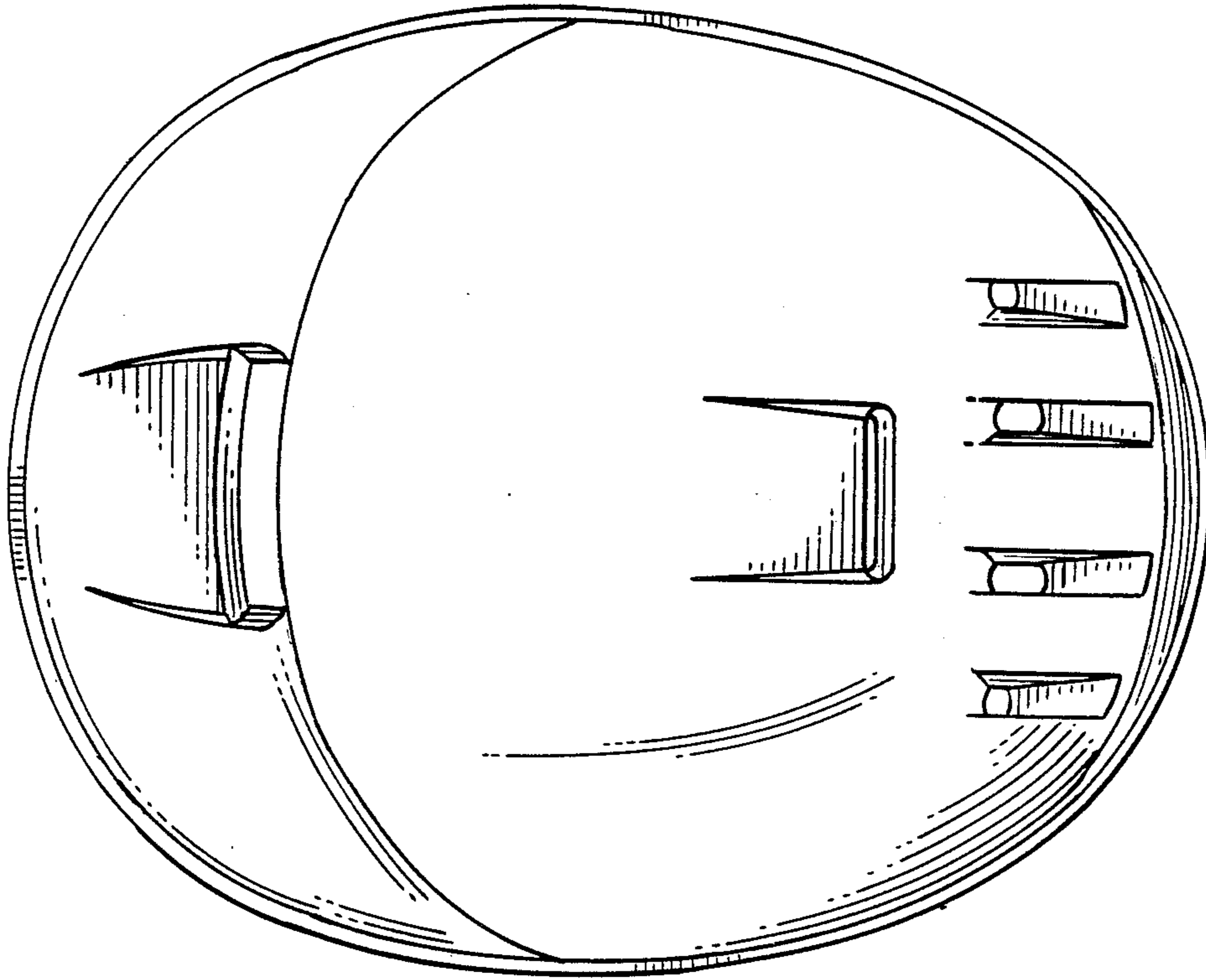

FIG. 2.

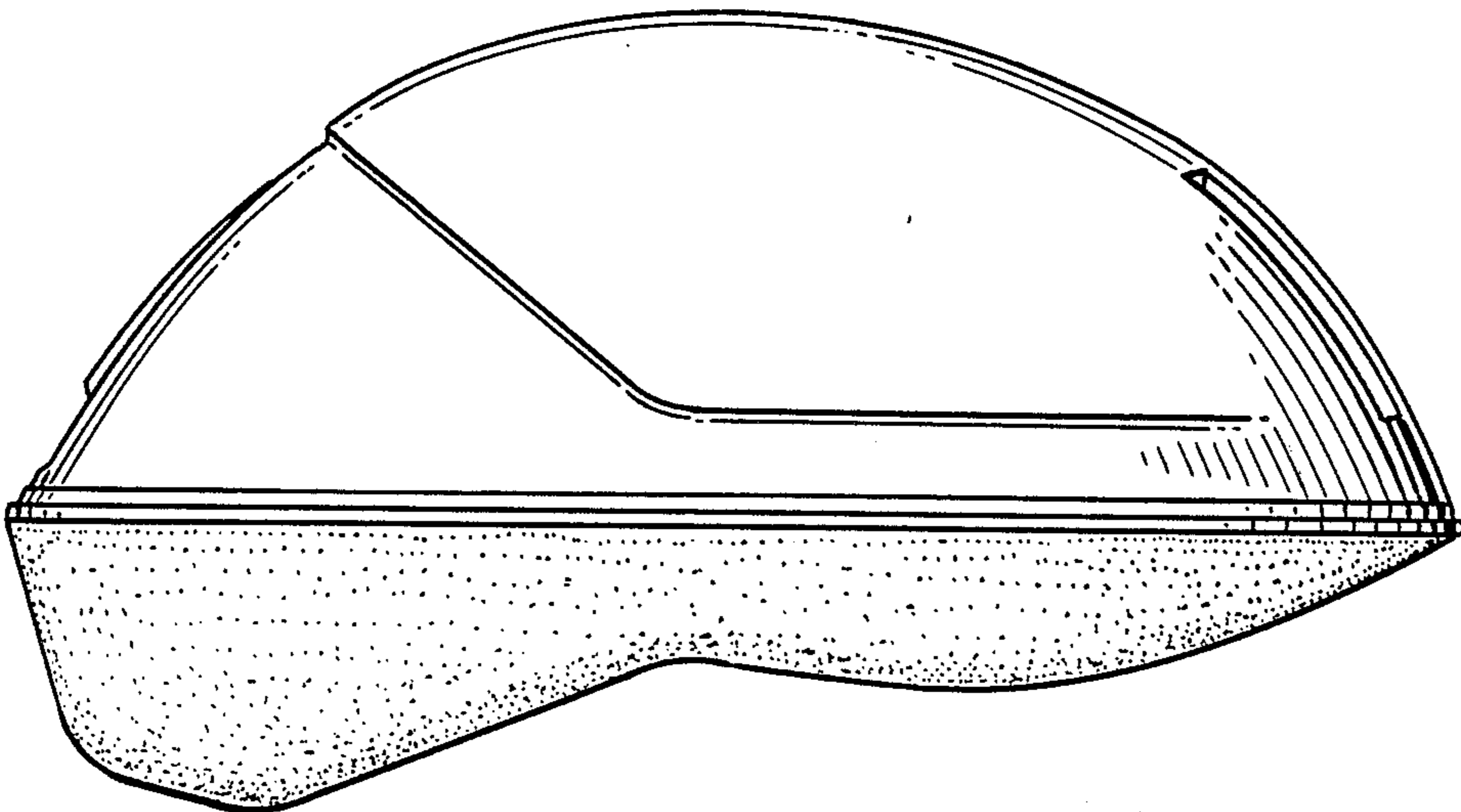

FIG. 3.

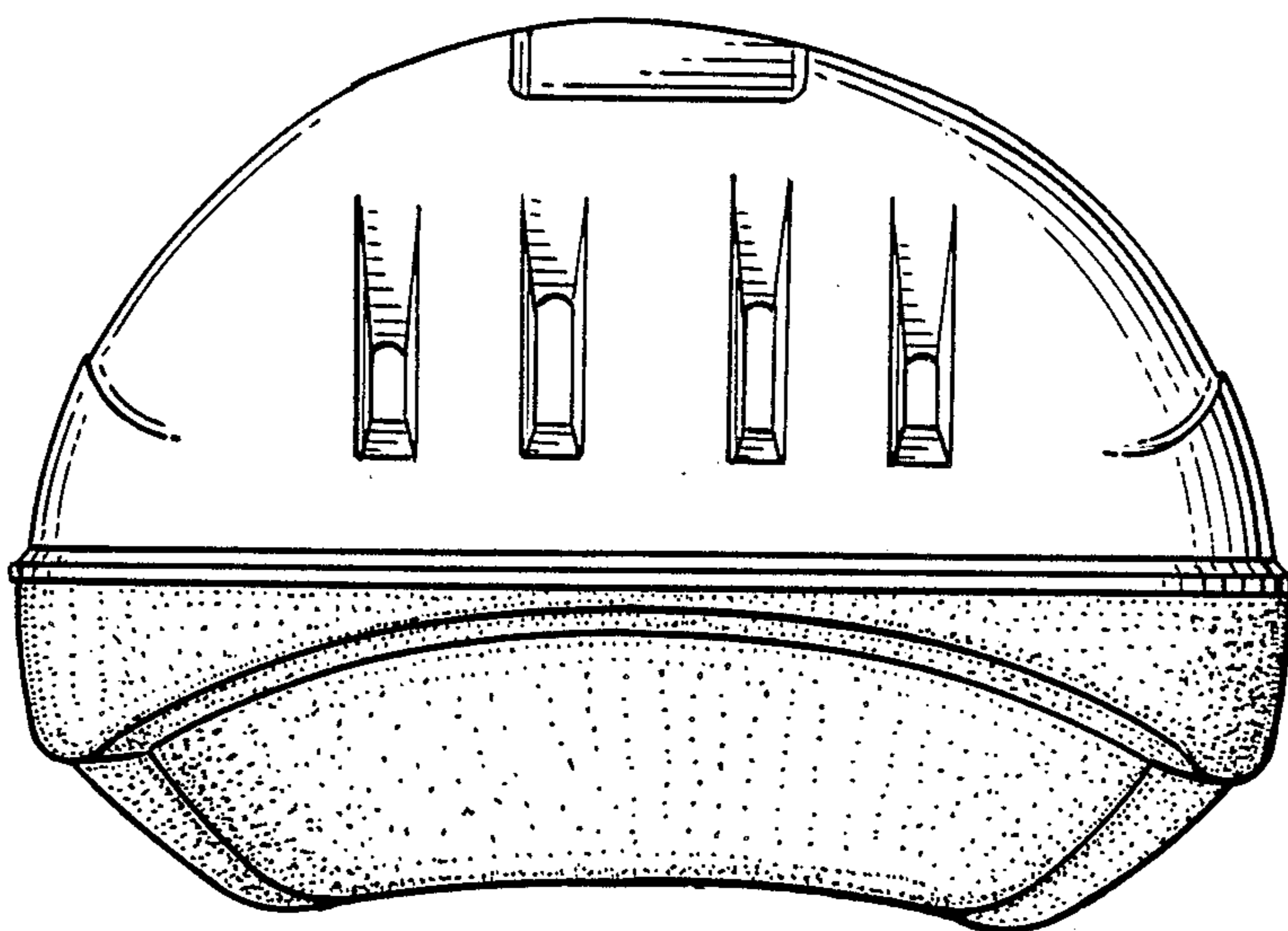

FIG. 4.

