

[54] HOUSING FOR DUAL VEHICLE WARNING LIGHTS

[76] Inventor: Joseph E. Baader, 333 Holiday Dr., Springfield, Ohio 45505

[**] Term: 14 Years

[21] Appl. No.: 202,064

[22] Filed: Jun. 3, 1988

[52] U.S. Cl. D26/139; D26/35

[58] Field of Search D26/28-36, D26/129; 362/61, 74, 80, 80.1, 80.2, 82, 83, 83.2, 83.3, 362; D10/114

[56] References Cited

U.S. PATENT DOCUMENTS

- D. 57,890 5/1921 Collier .
- D. 57,891 5/1921 Collier .
- D. 58,096 6/1921 Medén .
- D. 61,492 9/1922 Anthony D26/31
- D. 84,280 6/1931 Frame D26/139
- D. 84,725 7/1931 Adler, Jr. .
- D. 87,105 3/1932 Evich .
- D. 87,106 3/1932 Evich .
- D. 126,137 12/1940 Slawson .
- D. 164,276 8/1951 Berry D10/114

- D. 181,996 1/1958 Ornas, Jr. .
- D. 185,688 7/1959 Walker D26/139
- D. 226,130 1/1973 Meyer .
- 2,871,599 4/1954 Kolb .
- 2,885,539 6/1955 McDermott .
- 3,908,179 9/1975 Heehler et al. 340/471 X
- 4,272,799 6/1981 Downing 362/238 X

Primary Examiner—Susan J. Lucas
Attorney, Agent, or Firm—David H. Semmes

[57] CLAIM

The ornamental design for a housing for dual vehicle warning lights, as shown and described.

DESCRIPTION

FIG. 1 is a rear perspective view of a housing for dual vehicle warning lights showing my new design;
 FIG. 2 is a rear elevational view thereof on an enlarged scale;
 FIG. 3 is a side elevational view thereof on an enlarged scale, the opposite side being a mirror image;
 FIG. 4 is a front elevational view thereof on an enlarged scale;
 FIG. 5 is a top plan view thereof on an enlarged scale;
 FIG. 6 is a bottom plan view thereof on an enlarged scale.

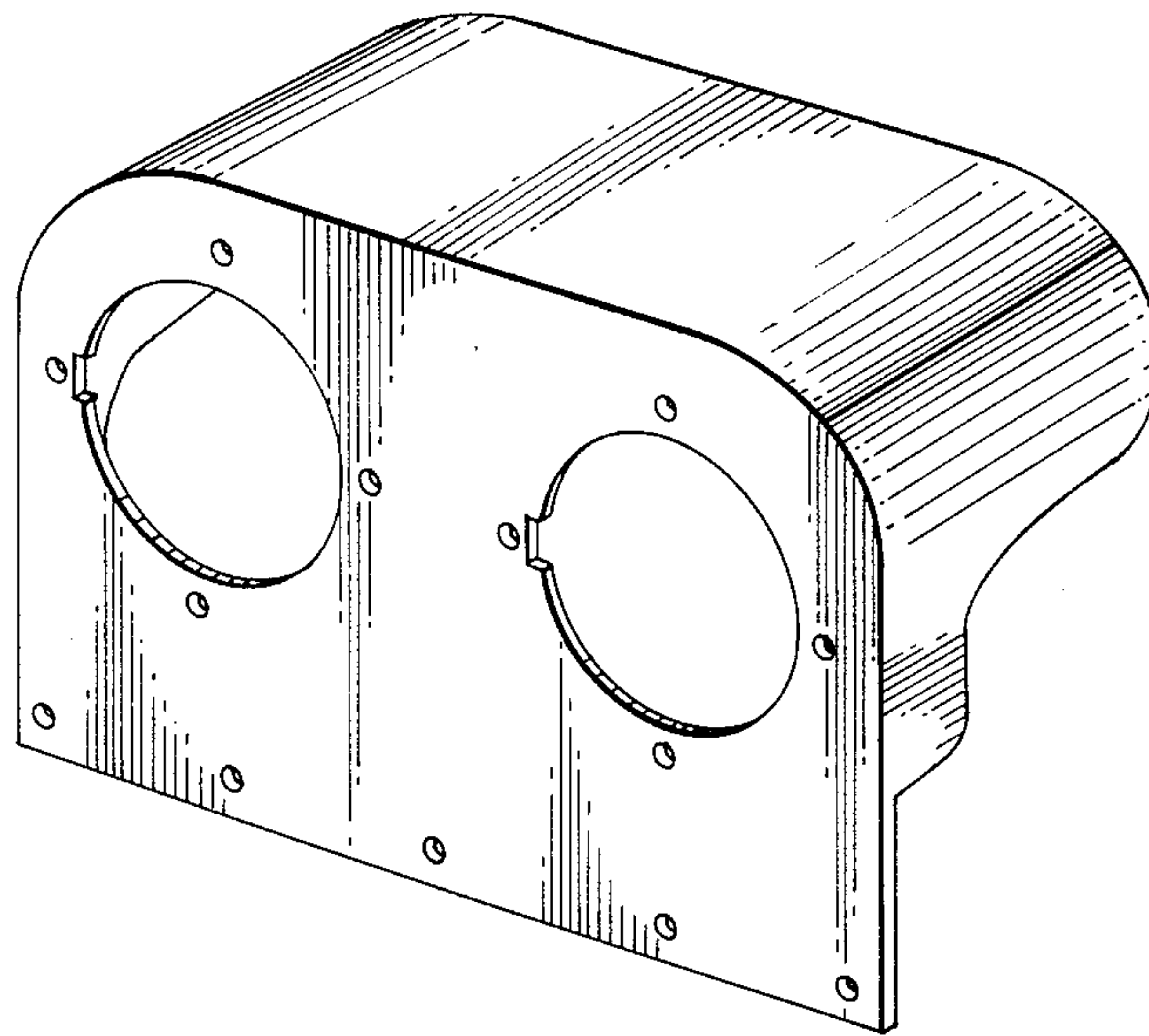

FIG. 1

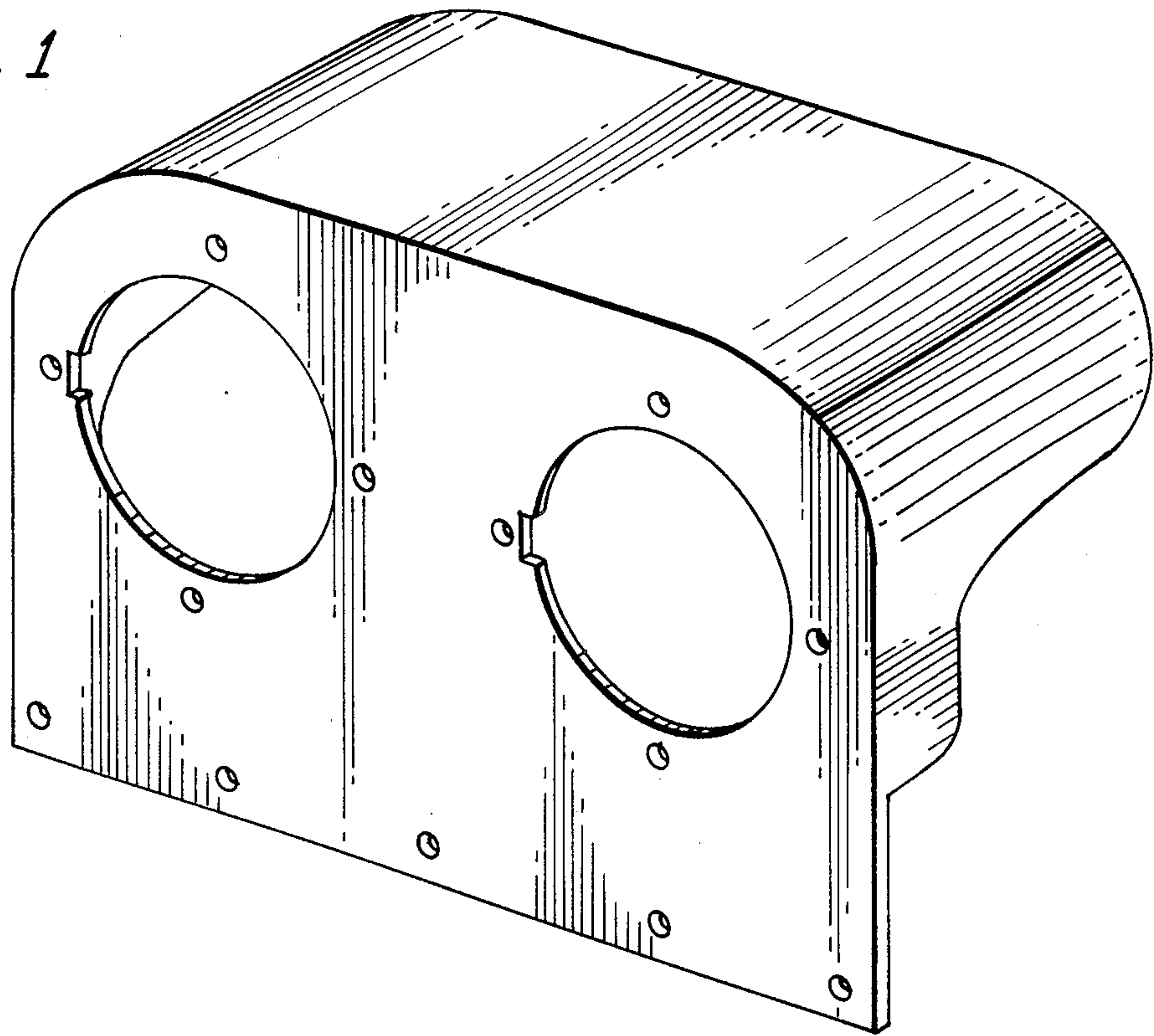
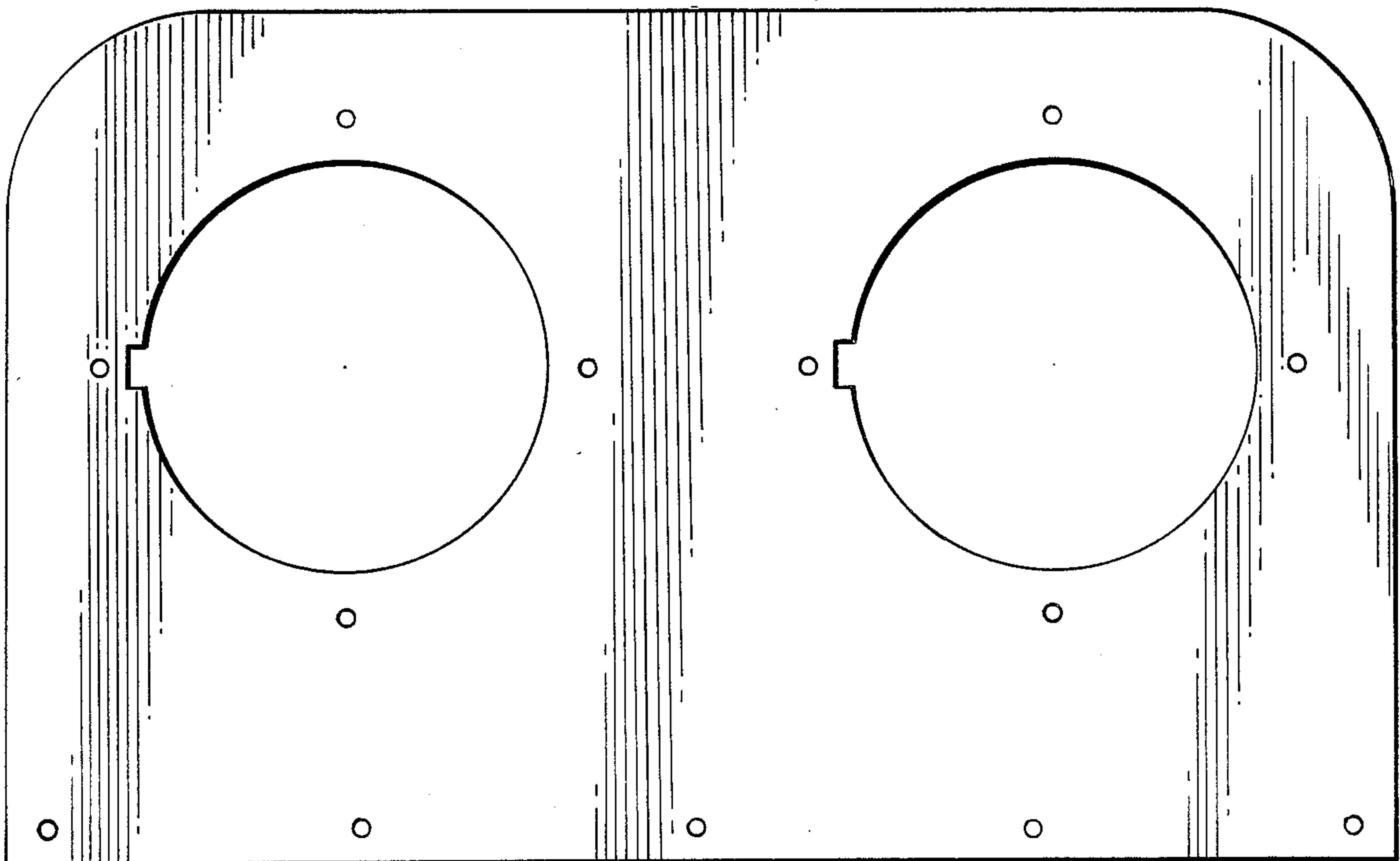

FIG. 2



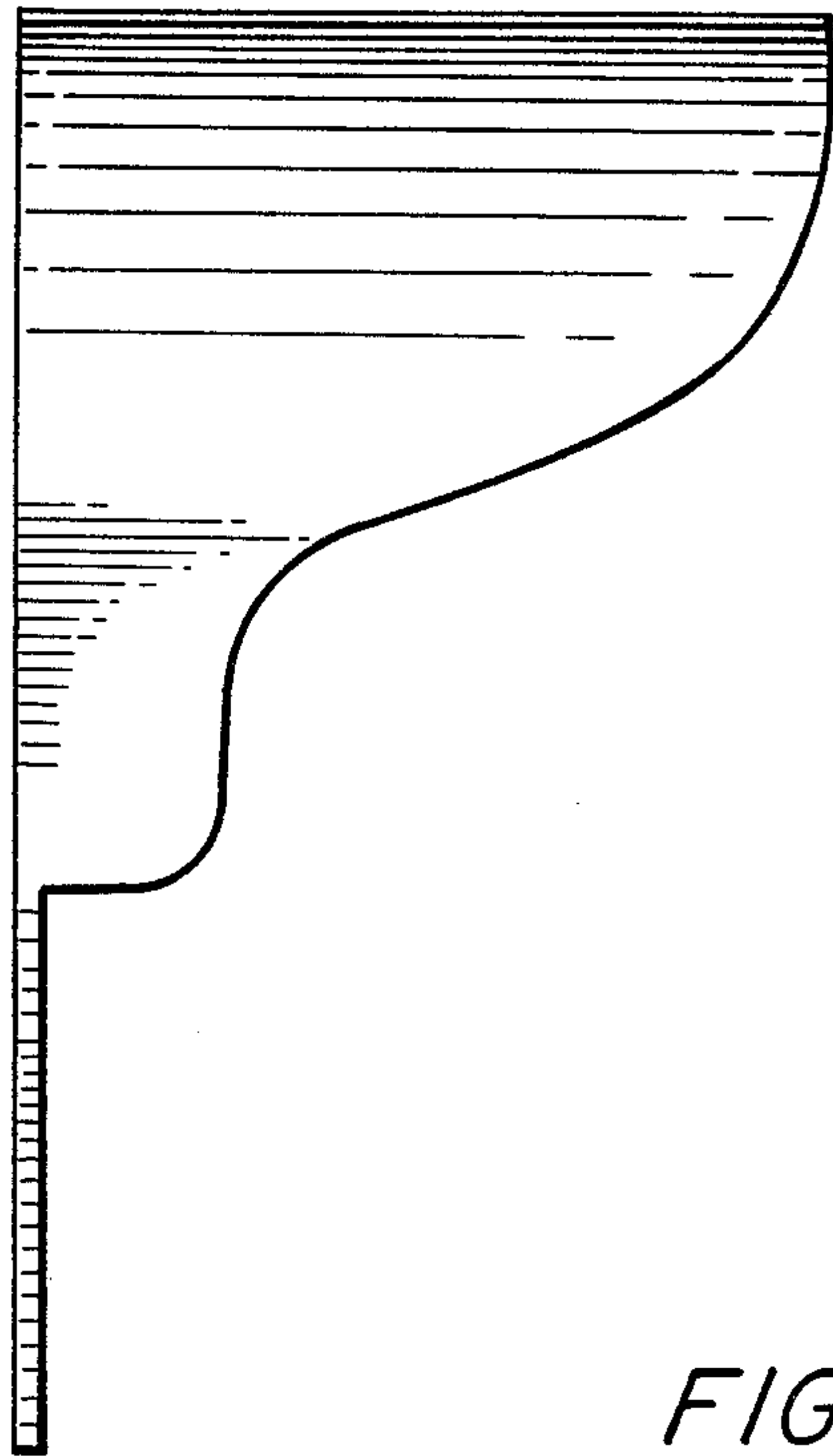

FIG. 3

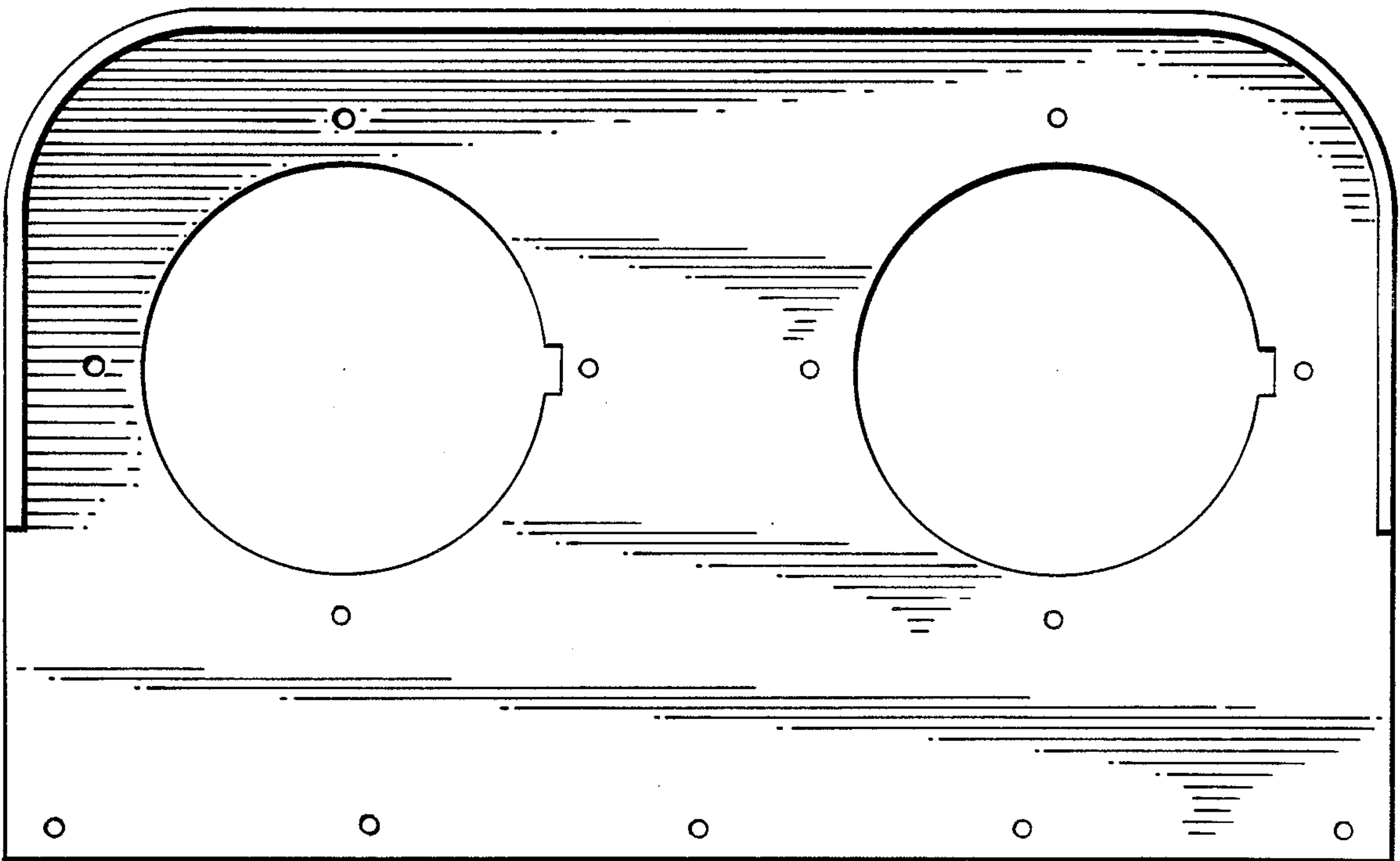

FIG. 4

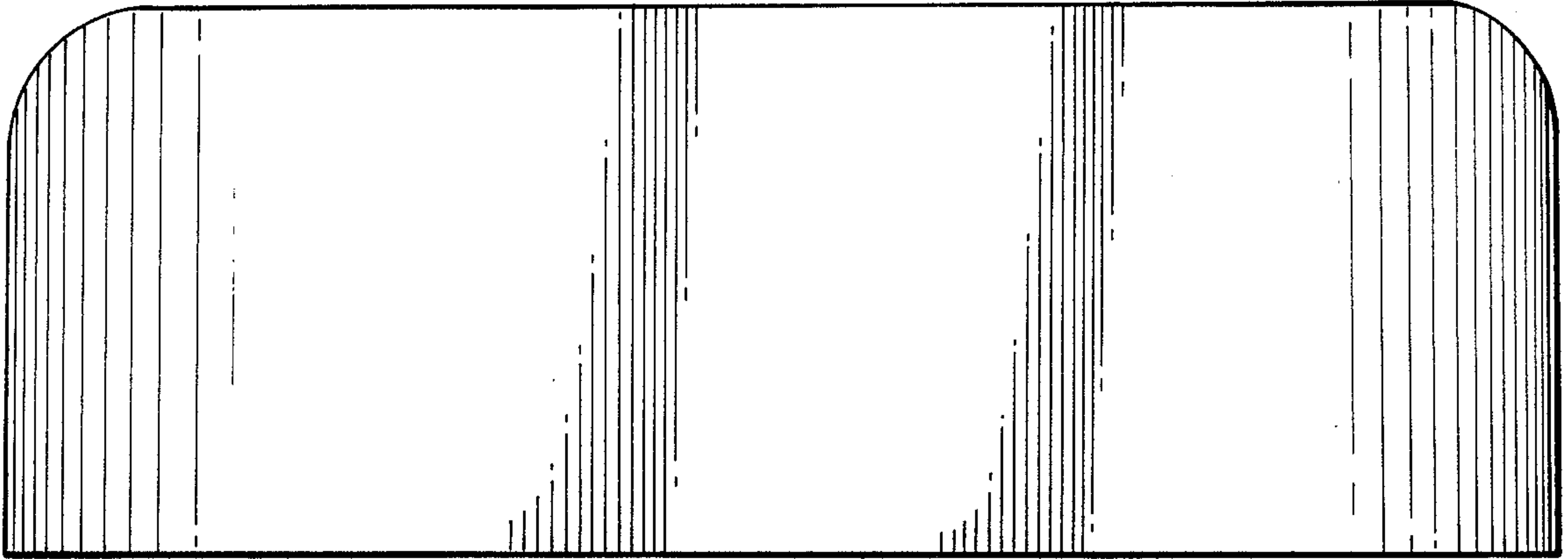

FIG. 5

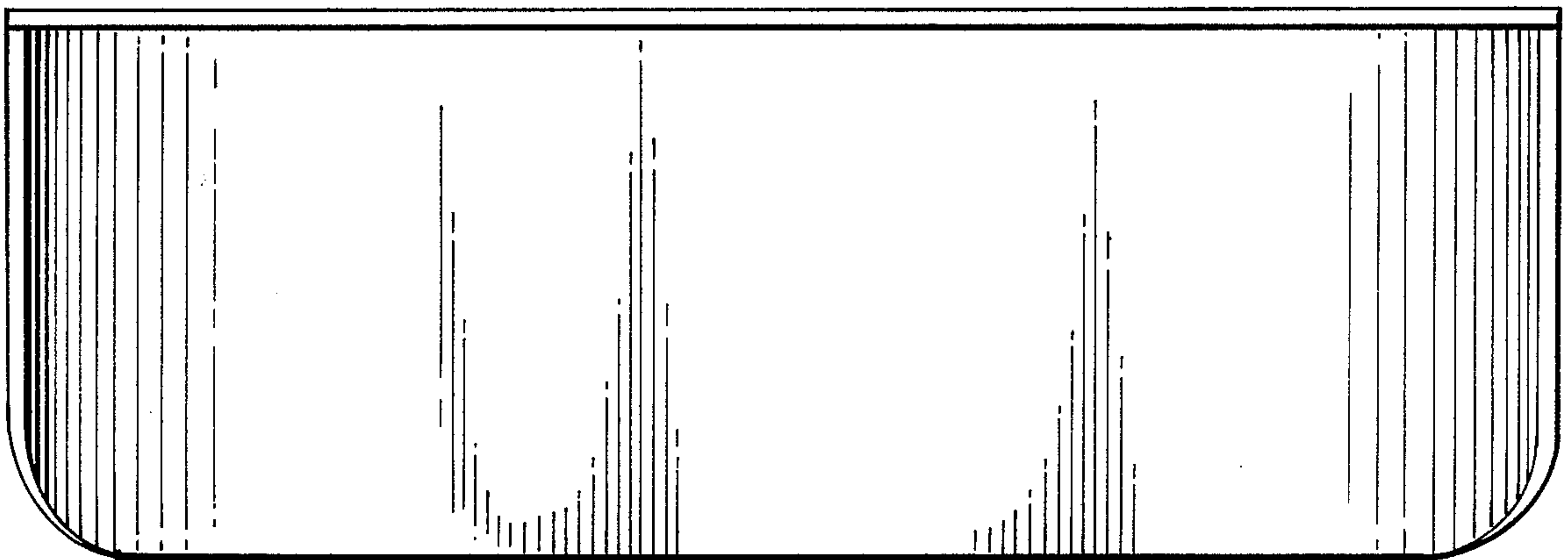

FIG. 6