

- [54] **COMBINED CURVED WAND TIP WITH SWIVEL-MOUNTED NOZZLE**
- [76] **Inventor: Robert W. Hengesbach, 7886 Munson Rd., Mentor, Ohio 44060**
- [\*\*] **Term: 14 Years**
- [21] **Appl. No.: 312,238**
- [22] **Filed: Feb. 21, 1989**

**Related U.S. Application Data**

- [60] **Division of Ser. No. 224,251, Jul. 26, 1988, which is a continuation of Ser. No. 15,604, Feb. 17, 1987, abandoned, which is a continuation-in-part of Ser. No. 674,272, Nov. 23, 1984, Pat. No. Des. 293,127, and a continuation-in-part of Ser. No. 461,874, Jan. 28, 1983, Pat. No. Des. 282,392.**
- [52] **U.S. Cl. .... D23/213**
- [58] **Field of Search .... D23/213, 223-227; 406/152; 141/19; 251/231; 294/25-26; 239/8, 134, 337, 525-526, 532**

**References Cited**

**U.S. PATENT DOCUMENTS**

- D. 183,042 6/1958 Fuglie et al. .... D91/3
- D. 212,610 11/1968 Wahlin ..... D23/226
- D. 234,845 4/1975 Davis ..... D23/1
- D. 243,532 3/1977 Fyffe ..... D23/223
- D. 254,146 2/1980 Koenig ..... D23/19
- D. 254,322 2/1980 Koenig ..... D23/19
- D. 257,537 11/1980 Chow et al. .... D23/226
- D. 270,368 8/1983 Grime ..... D23/1
- D. 282,392 1/1986 Hengesbach ..... D23/17
- D. 284,301 6/1986 Hengesbach ..... D23/17
- D. 285,242 8/1986 Hengesbach ..... D23/17
- D. 285,477 9/1986 Hengesbach ..... D23/18
- D. 285,478 9/1986 Hengesbach ..... D23/19
- D. 285,479 9/1986 Hengesbach ..... D23/20
- D. 288,229 2/1987 Beal et al. .... D23/43
- D. 293,137 12/1987 Hengesbach ..... D23/226
- 336,602 2/1886 Tomlinson .
- 370,836 10/1887 Wilkins .
- 511,728 12/1893 Deming .
- 564,500 7/1896 Benedict et al. .
- 676,526 6/1901 Anderson .
- 915,694 3/1909 Pendergrass .
- 949,489 2/1910 Mastin .
- 1,605,617 11/1926 Ruemelin .

- 1,743,537 1/1930 Freese .
- 2,072,555 3/1937 Hengesbach et al. .... 122/144
- 2,157,269 5/1939 Richter ..... 158/27.4
- 2,293,390 8/1942 Hengesbach ..... 299/84
- 2,333,727 9/1945 Lucas ..... 47/49
- 2,366,969 1/1945 Kiggins ..... 299/140
- 2,421,103 5/1947 Wadsworth ..... 285/209
- 2,421,104 5/1947 Wadsworth ..... 285/97.5
- 2,564,938 8/1951 Warren ..... 285/95
- 2,657,098 10/1953 Straham ..... 299/131
- 2,783,092 2/1957 Gavin et al. .... 299/116
- 2,788,926 4/1957 Morrison ..... 222/394
- 2,890,067 6/1959 Morin ..... 285/166
- 2,929,406 3/1960 Anderson ..... 137/615
- 3,116,882 1/1964 Vork ..... 239/587
- 3,202,360 8/1965 O'Brien ..... 239/119
- 3,319,893 5/1967 Rodgers et al. .... 239/393
- 3,475,039 10/1969 Ortloff ..... 285/45
- 3,556,411 1/1971 Nord et al. .... 239/581
- 3,632,046 1/1972 Hengesbach ..... 239/318
- 3,711,028 1/1973 Hengesbach ..... 239/288.5
- 3,727,841 4/1973 Hengesbach ..... 239/145
- 3,756,273 9/1973 Hengesbach ..... 137/540
- 3,814,329 6/1974 Clark ..... 239/426
- 3,955,763 5/1976 Pyle et al. .... 239/119
- 4,035,004 7/1977 Hengesbach ..... 285/166
- 4,206,877 6/1980 Hoza, III ..... 239/524
- 4,449,696 5/1984 Hengesbach ..... 251/231
- 4,473,328 9/1984 Hengesbach ..... 406/152
- 4,531,675 7/1985 Muck ..... 239/290
- 4,569,160 2/1986 Hengesbach ..... 51/427
- 4,629,121 12/1986 Hengesbach ..... 239/119

**FOREIGN PATENT DOCUMENTS**

- 874866 7/1971 Canada .
- 937262 11/1973 Canada .
- 952559 8/1974 Canada .
- 998716 10/1976 Canada .
- 1029422 4/1978 Canada ..... 299/15
- 1040236 10/1978 Canada ..... 299/15
- 1045657 1/1979 Canada .
- 2266070 10/1976 France .

**OTHER PUBLICATIONS**

- Brochure, Tri-Con, Inc., 4 pages, dated 1/1/1977, entitled: We Make the System.
- Brochure, Spraying Systems Co., Catalog 27, pp. 75-79, 1978, entitled: Spray Nozzles and Accessories.
- Brochure, Spraying Systems Co., Bulletin 179F, 7

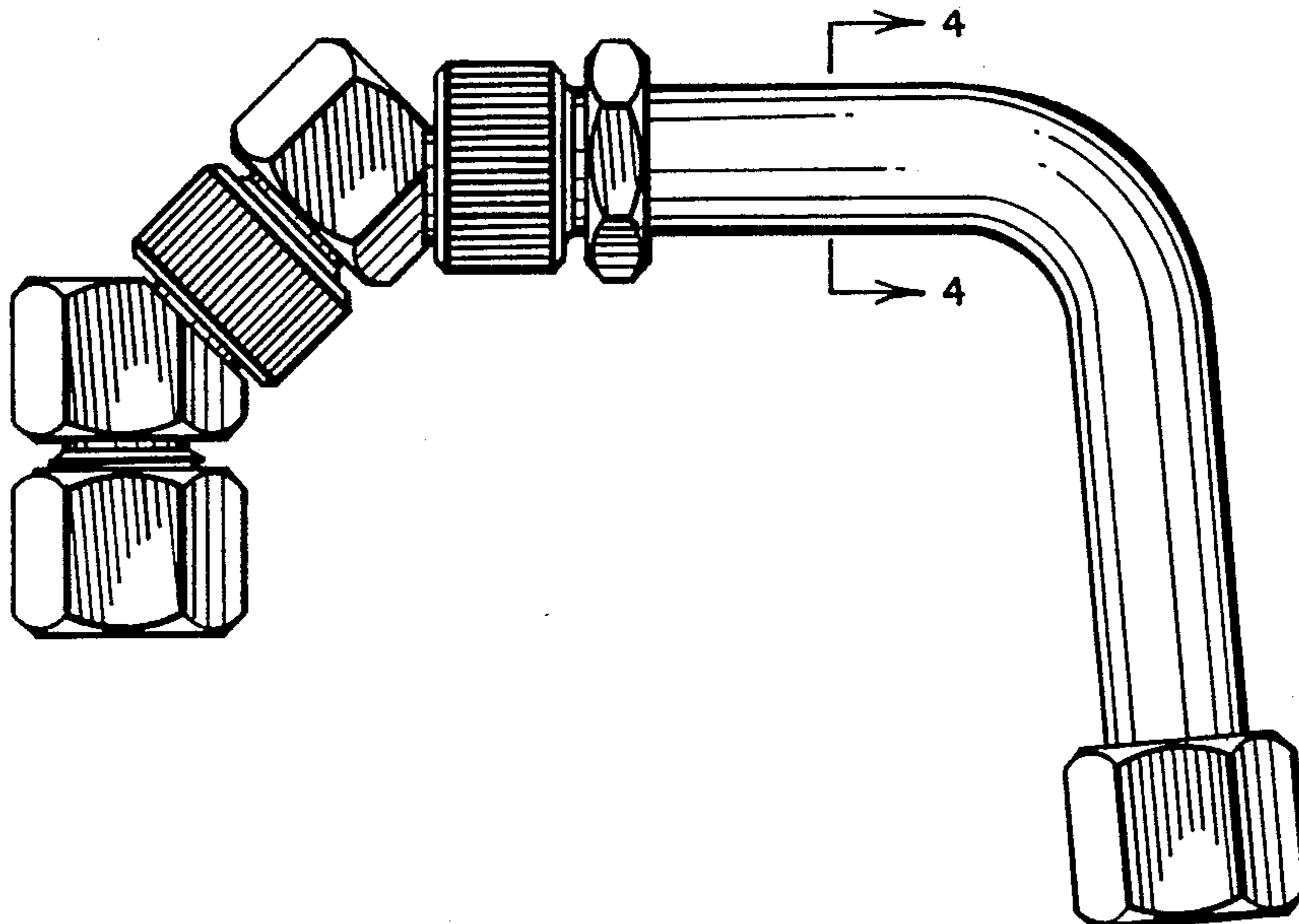

pages, 1971, entitled: Spray Nozzles, Spray Guns, Valves and Accessories.

Brochure, Tri-Con, Inc., 2 pages, dated unknown, entitled: Tri-Con Rust-Fighter Vehicle Inner-Body Coating System 9000.

Brochure, Tri-Con, Inc., 4 pages, date unknown, entitled: The Tri-Con All Purpose Nozzle.

*Primary Examiner*—Wallace R. Burke

*Assistant Examiner*—Brian N. Vinson

*Attorney, Agent, or Firm*—David A. Burge

[57]

**CLAIM**

The ornamental design for a combined curved wand tip with swivel-mounted nozzle, as shown and described.

**DESCRIPTION**

FIG. 1 is a left side elevational view of a combined curved wand tip with swivel-mounted nozzle showing my new design;

FIG. 2 is a front end elevational view thereof;

FIG. 3 is a rear end elevational view thereof;

FIG. 4 is a partial vertical cross-sectional view thereof, taken along line 4—4 of FIG. 1, with portions omitted for convenience of illustration;

FIG. 5 is a top plan view thereof;

FIG. 6 is a bottom plan view thereof;

FIG. 7 is a left side elevational view thereof, with the nozzle portion shown swiveled leftward;

FIG. 8 is a left side elevational view thereof, with the nozzle portion shown swiveled forward;

FIG. 9 is a left side elevational view thereof, with the nozzle portion shown swiveled rightward;

FIG. 10 is a left side elevational view of a second embodiment thereof;

FIG. 11 is a front end elevational view of the embodiment of FIG. 10;

FIG. 12 is a rear end elevational view of the embodiment of FIG. 10;

FIG. 13 is a partial vertical cross-sectional view thereof, taken along line 13—13 of FIG. 10, with portions omitted for convenience of illustration;

FIG. 14 is a top plan view of the embodiment of FIG. 10;

FIG. 15 is a bottom plan view of the embodiment of FIG. 10;

FIG. 16 is a left side elevational view of the embodiment of FIG. 10, with the nozzle portion shown swiveled leftward;

FIG. 17 is a left side elevational view of the embodiment of FIG. 10, with the nozzle portion shown swiveled leftward; and,

FIG. 18 is a left side elevational view of the embodiment of FIG. 10, with the nozzle portion shown swiveled rightward.

The terminal portions of FIGS. 7-9 and 16-18 have been omitted for convenience of illustration.



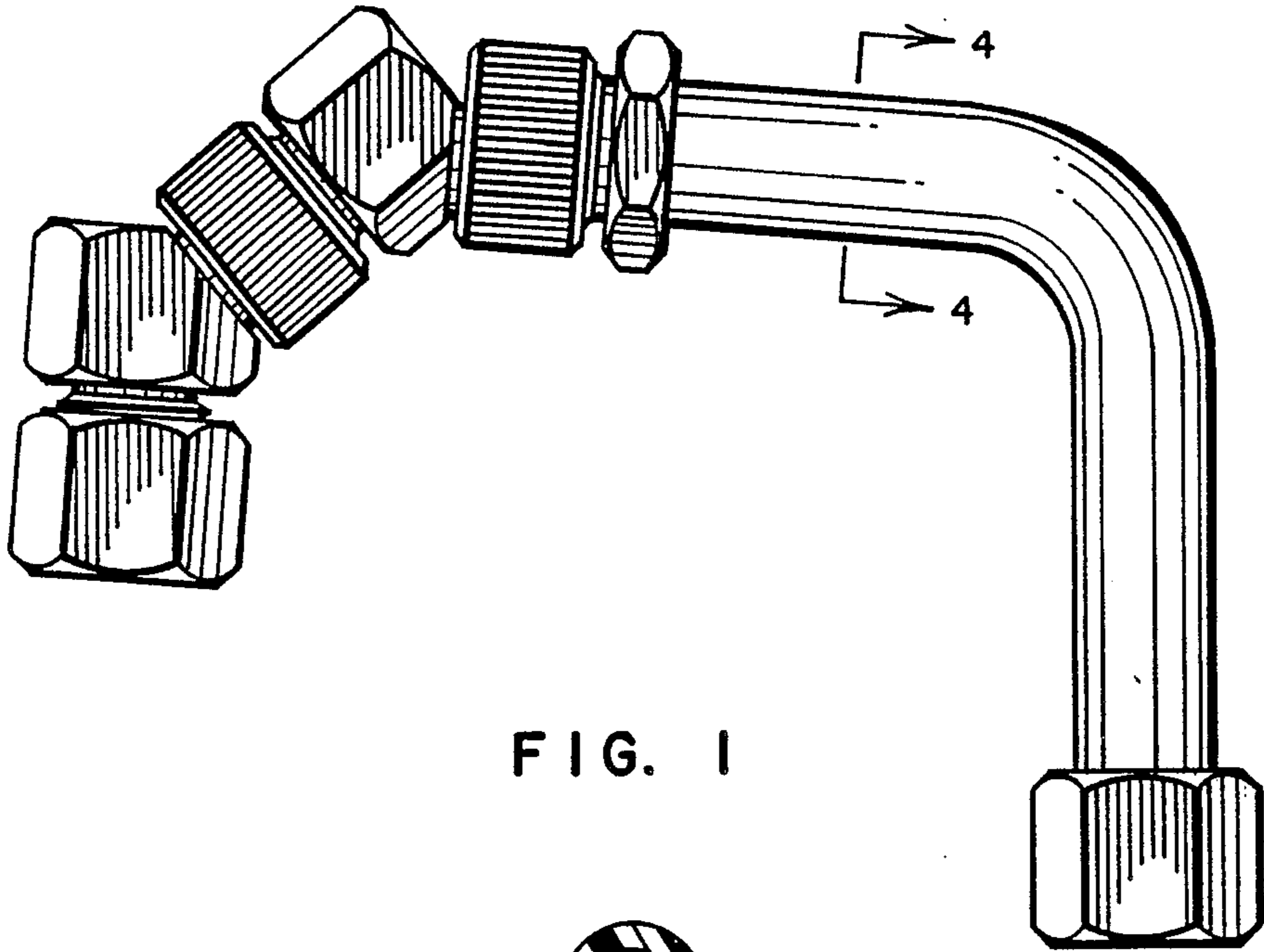

FIG. 1



FIG. 4

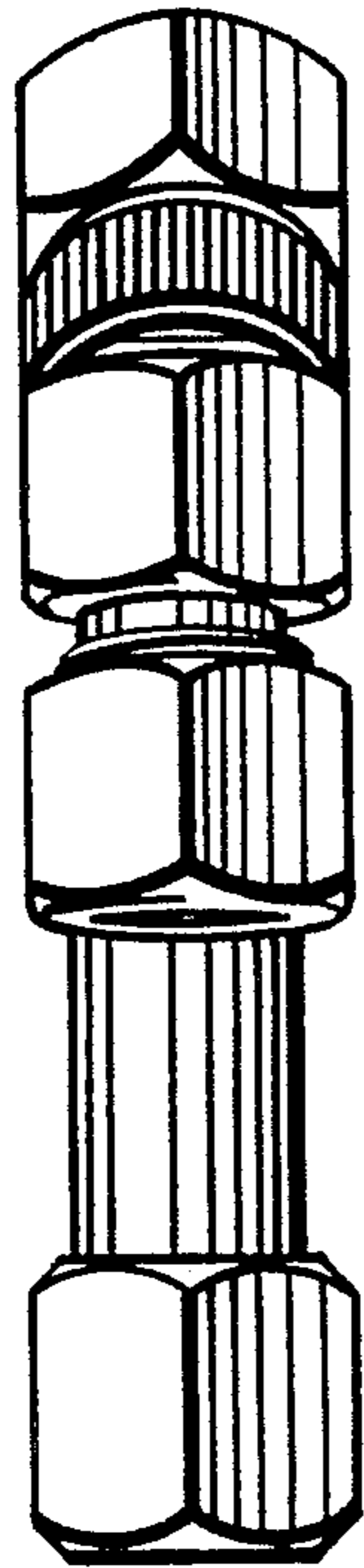

FIG. 2

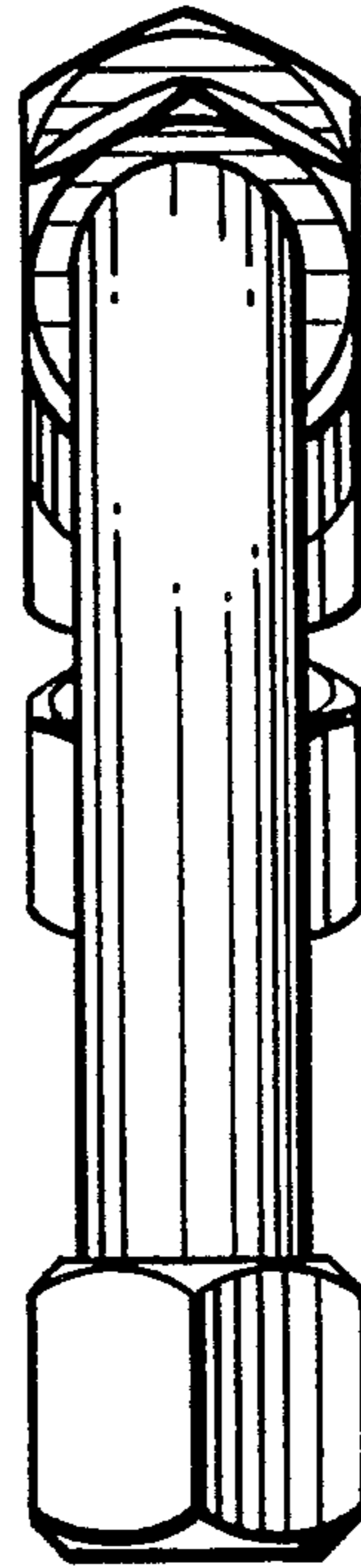

FIG. 3

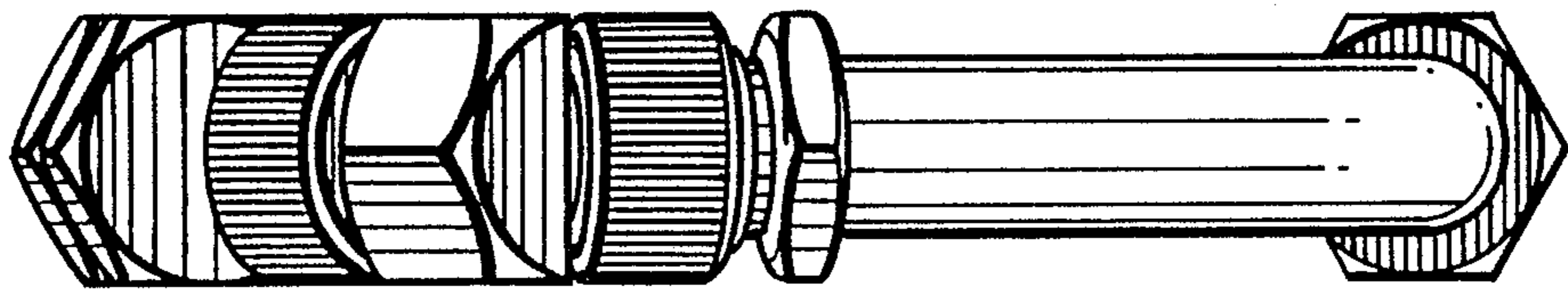

FIG. 5

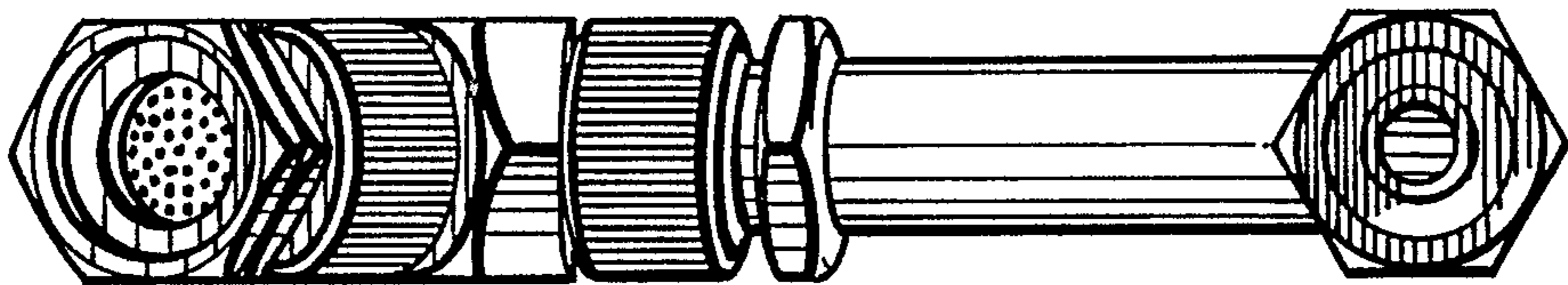

FIG. 6

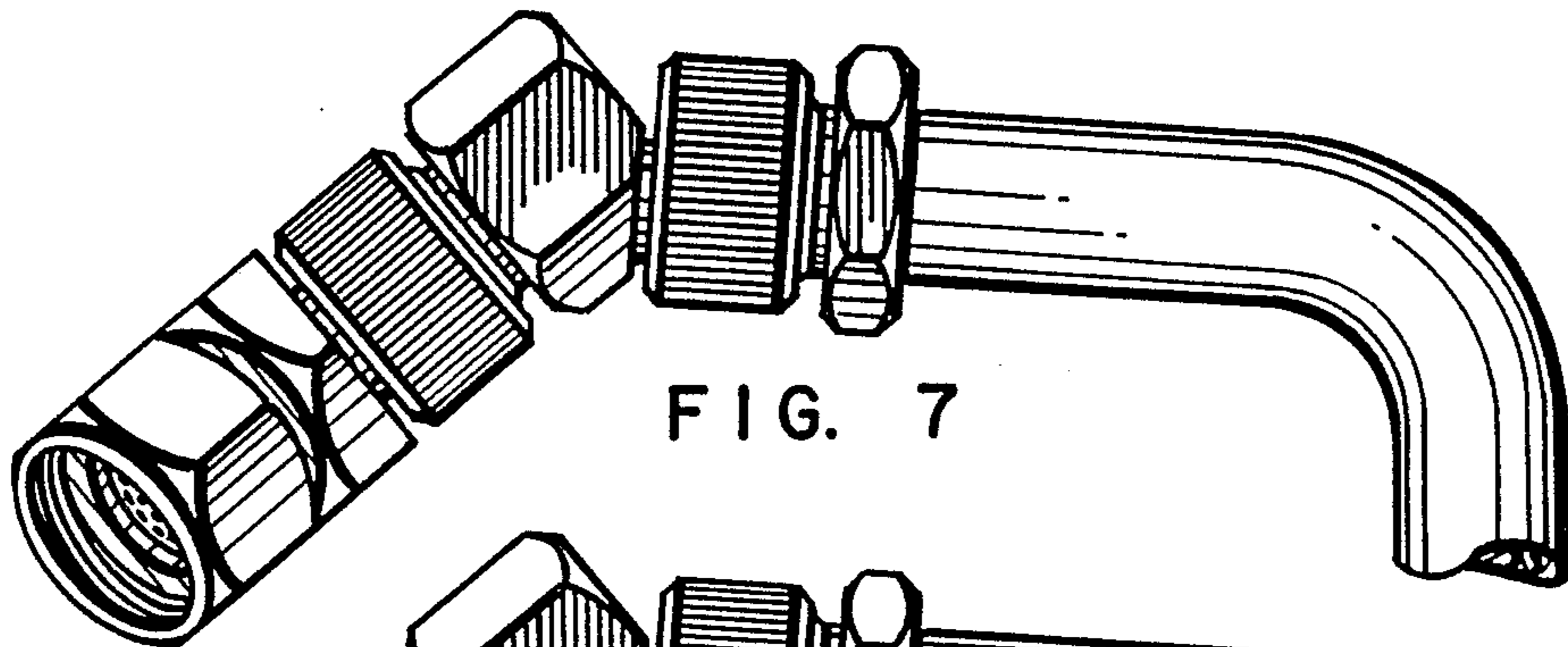

FIG. 7

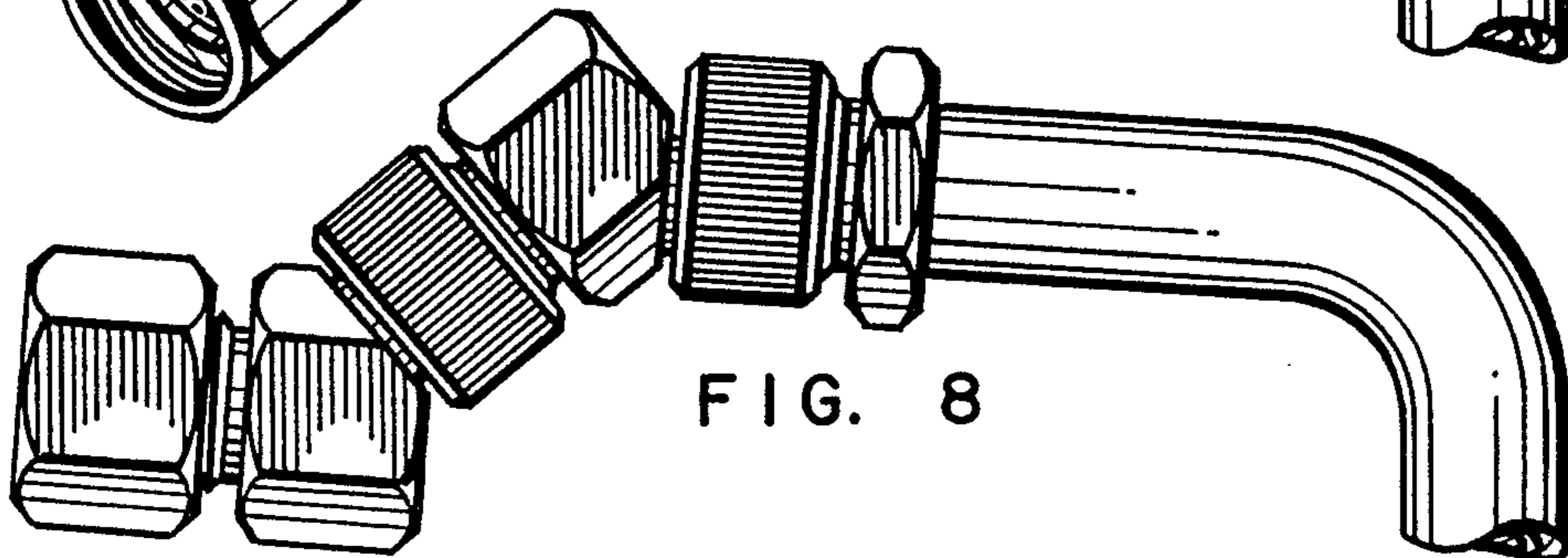

FIG. 8

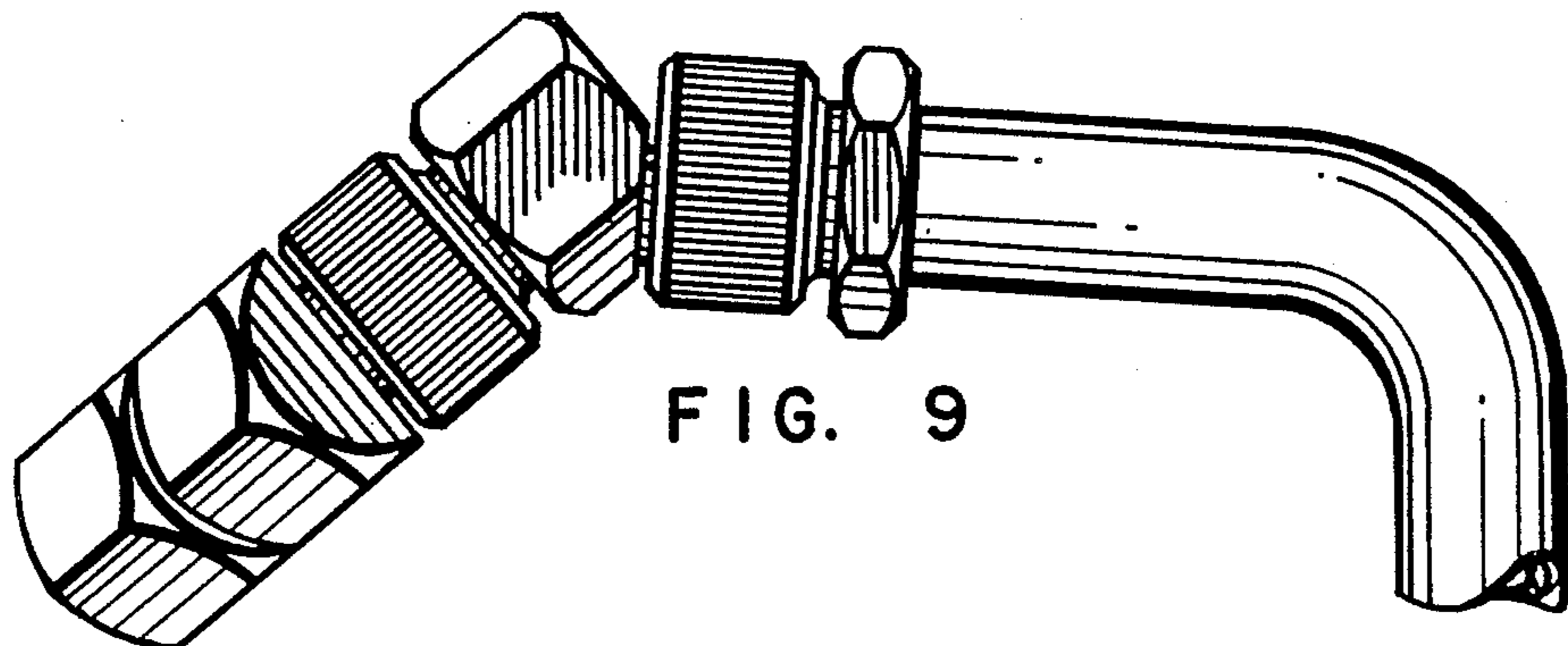

FIG. 9

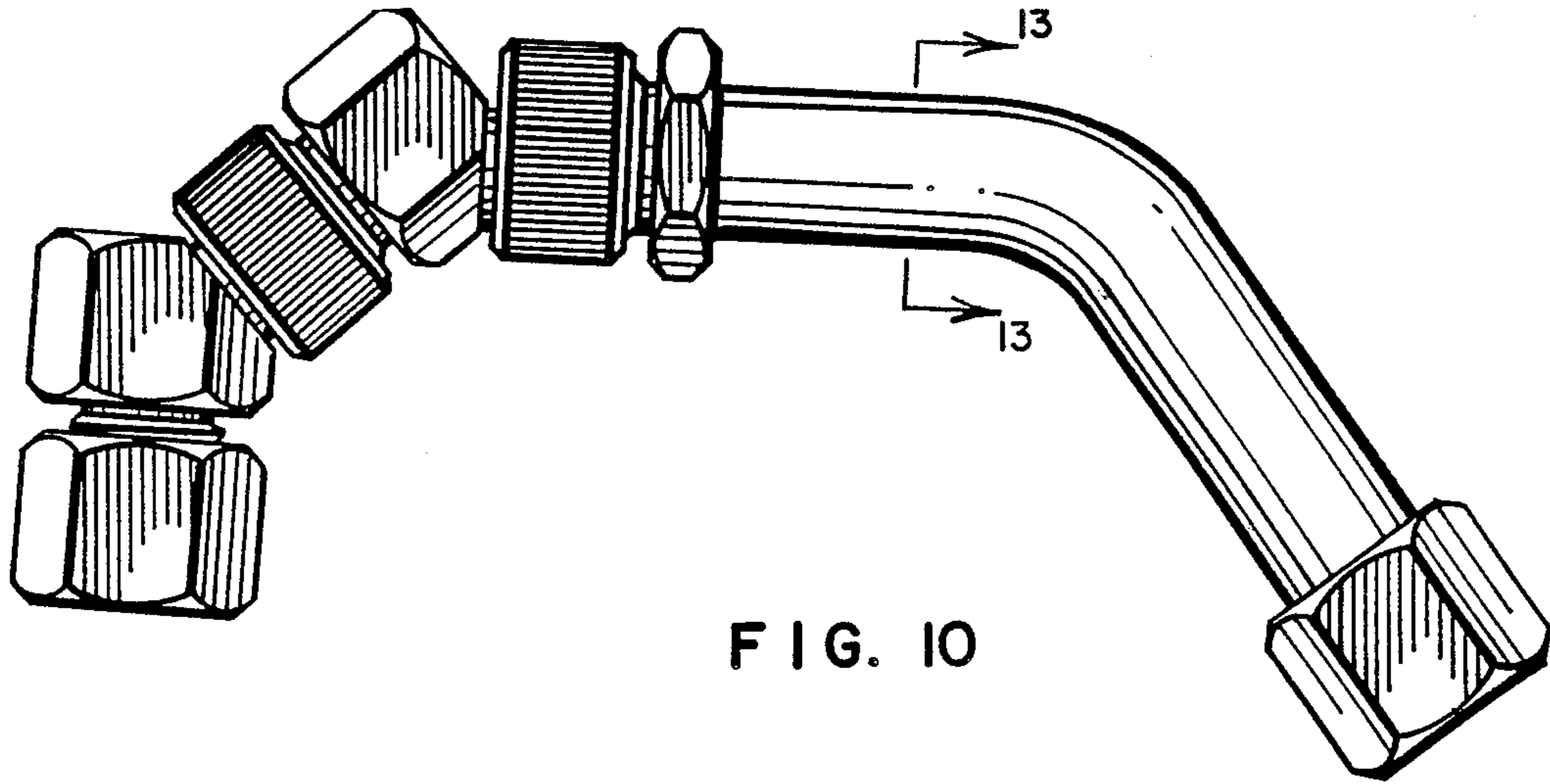

FIG. 13

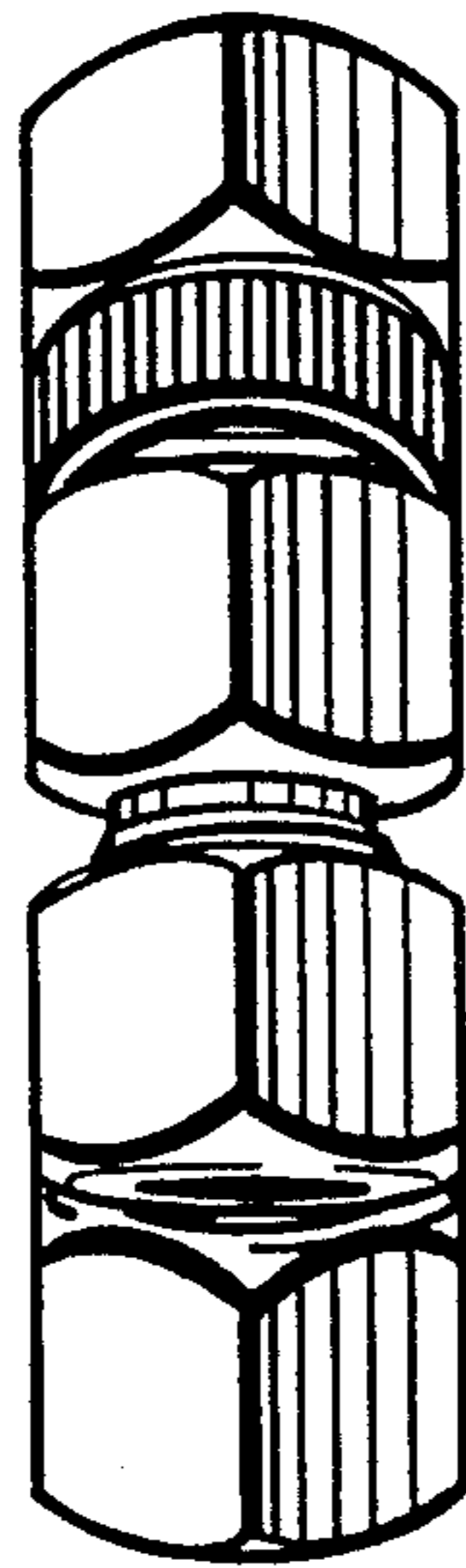

FIG. 11

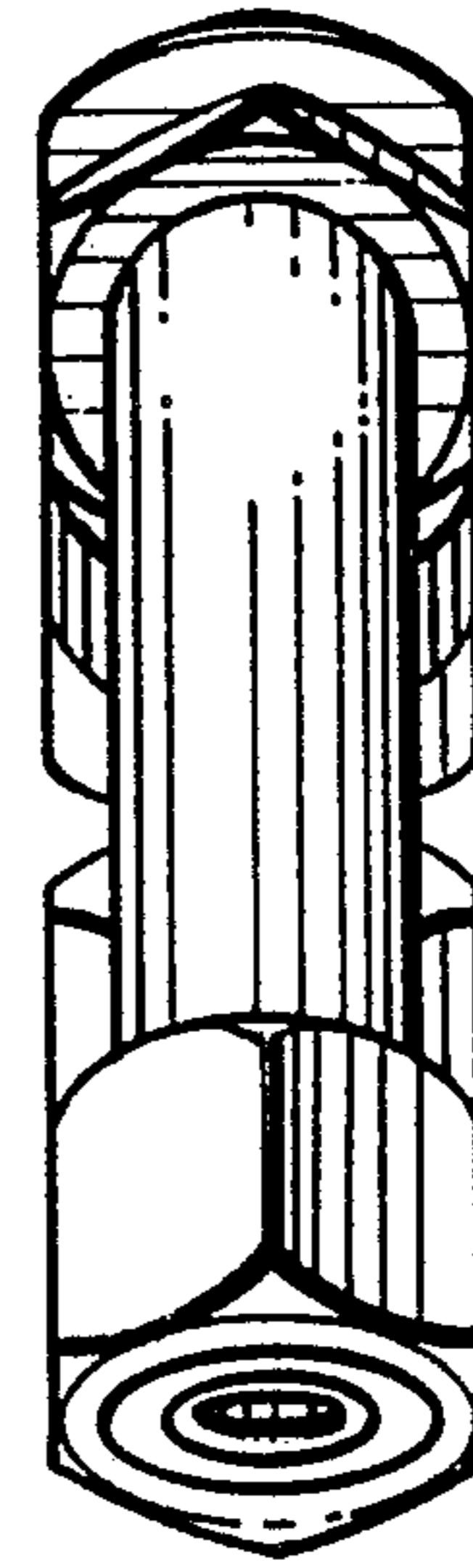

FIG. 12



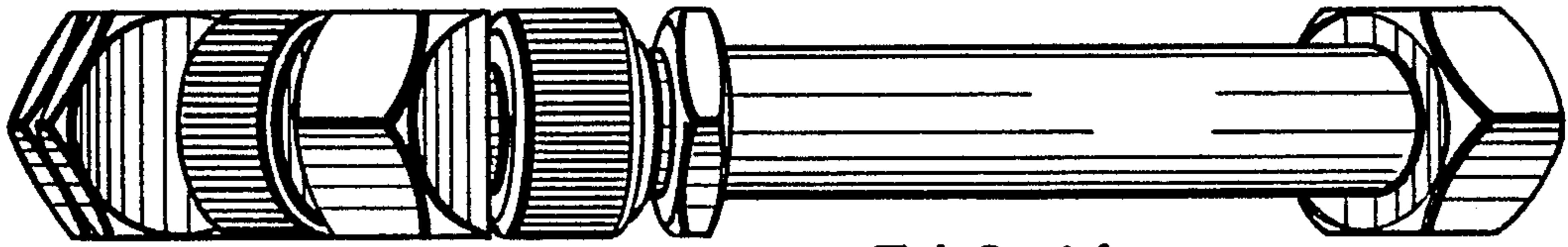

FIG. 14

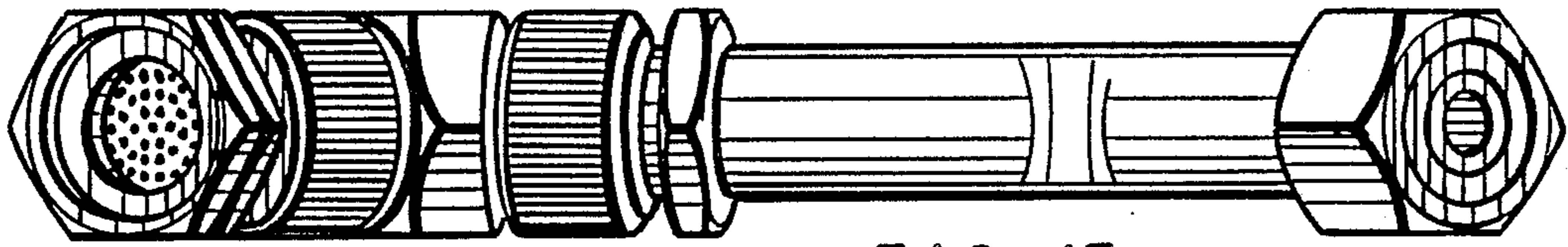

FIG. 15

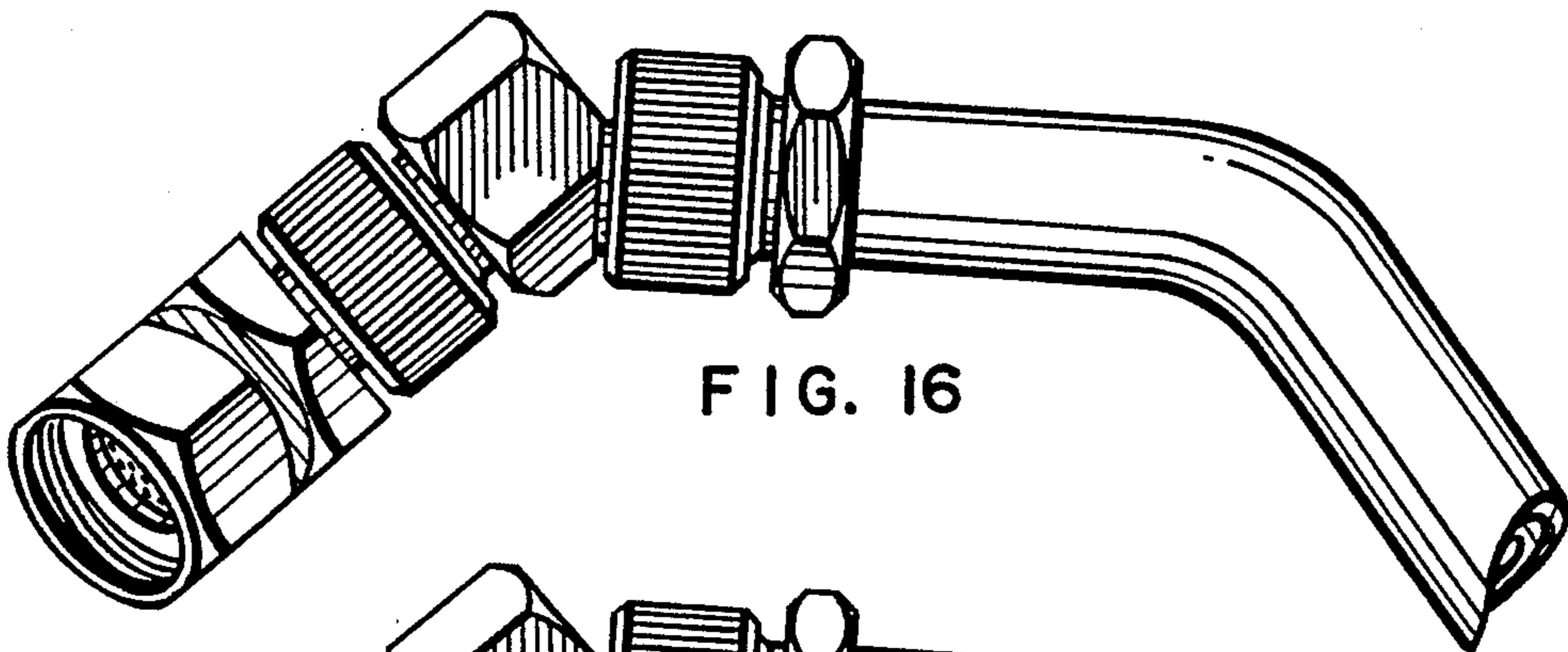

FIG. 16

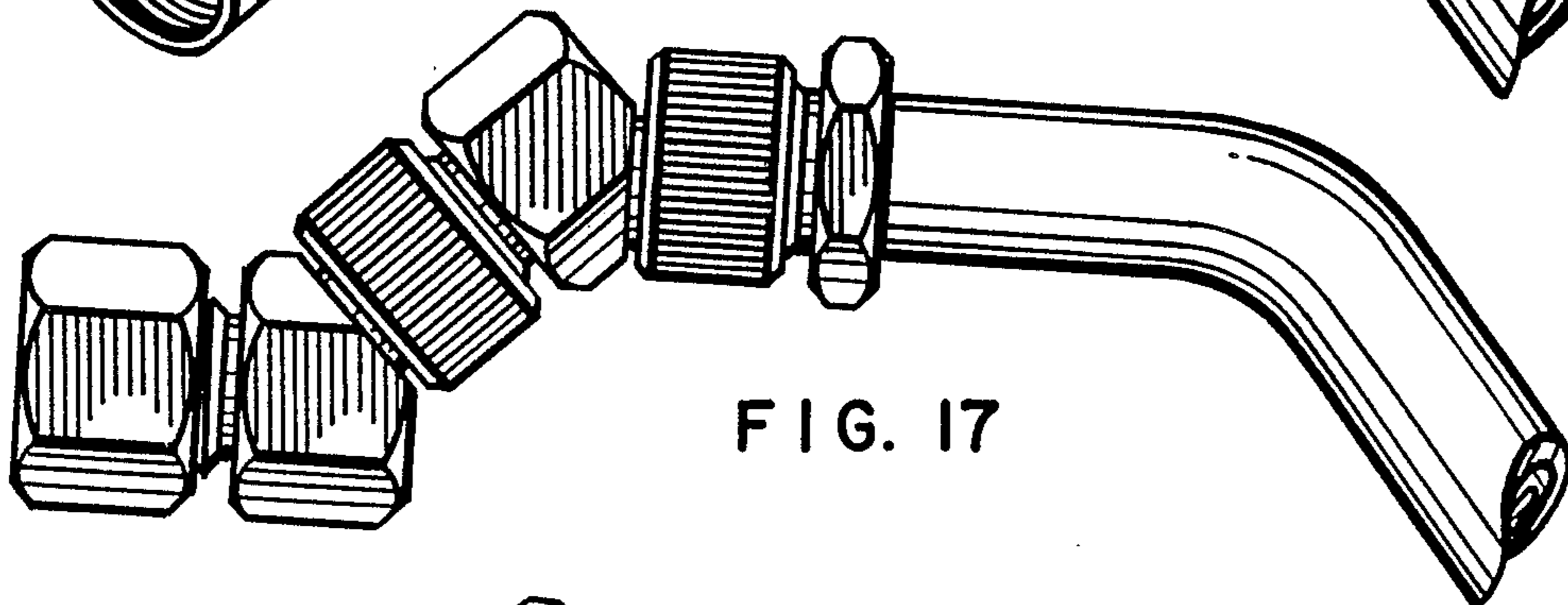

FIG. 17

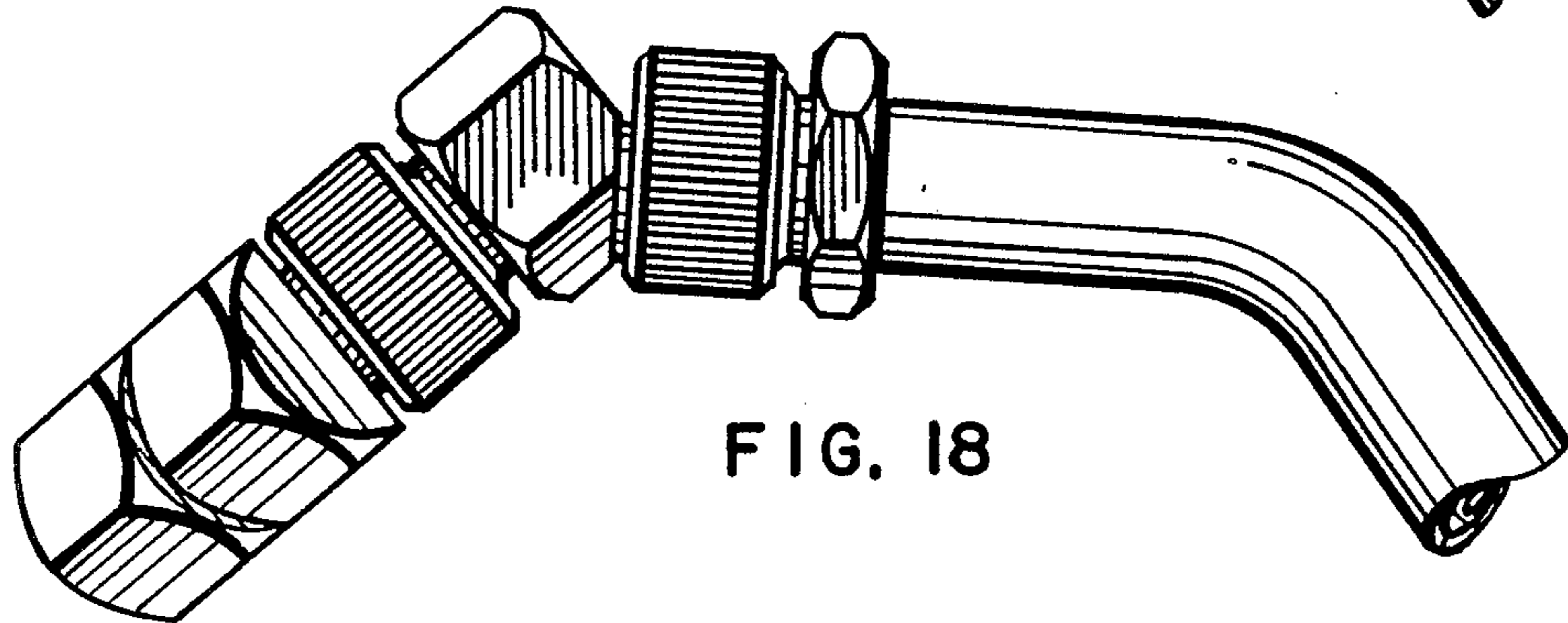

FIG. 18