

[54] MARINE RADIO

[75] Inventors: Douglas W. Low, Essex, Conn.; Elizabeth M. Pierotti, Grand View, N.Y.

[73] Assignee: International Marine Industries, Inc., Stamford, Conn.

[\*\*] Term: 14 Years

[21] Appl. No.: 249,081

[22] Filed: Sep. 23, 1988

[52] U.S. Cl. .... D14/137

[58] Field of Search ..... D14/124, 137-139, D14/157-159, 191, 218, 251, 257-258, 299; 455/73, 89, 90

[56] References Cited

U.S. PATENT DOCUMENTS

- D. 248,733 8/1978 Haynes ..... D14/137 X
- D. 260,770 9/1981 Fukushima et al. .... D14/138
- D. 281,974 12/1985 Suzuki et al. .... D14/138
- D. 292,210 10/1987 Imazeki ..... D14/137

OTHER PUBLICATIONS

- National Technical Report, vol. 23, No. 5, Oct. 1977, p. 696, Mobile Radio-Telephone for Bahrain.
- Boating, Jan. 1988, p. 161, Northstar 800 Loran.
- Boating, Apr. 1988, p. 73, King 8002 Loran.

Radio Shack, 1988 catalog, p. 77, top-54-Ch. Marine Transceiver.

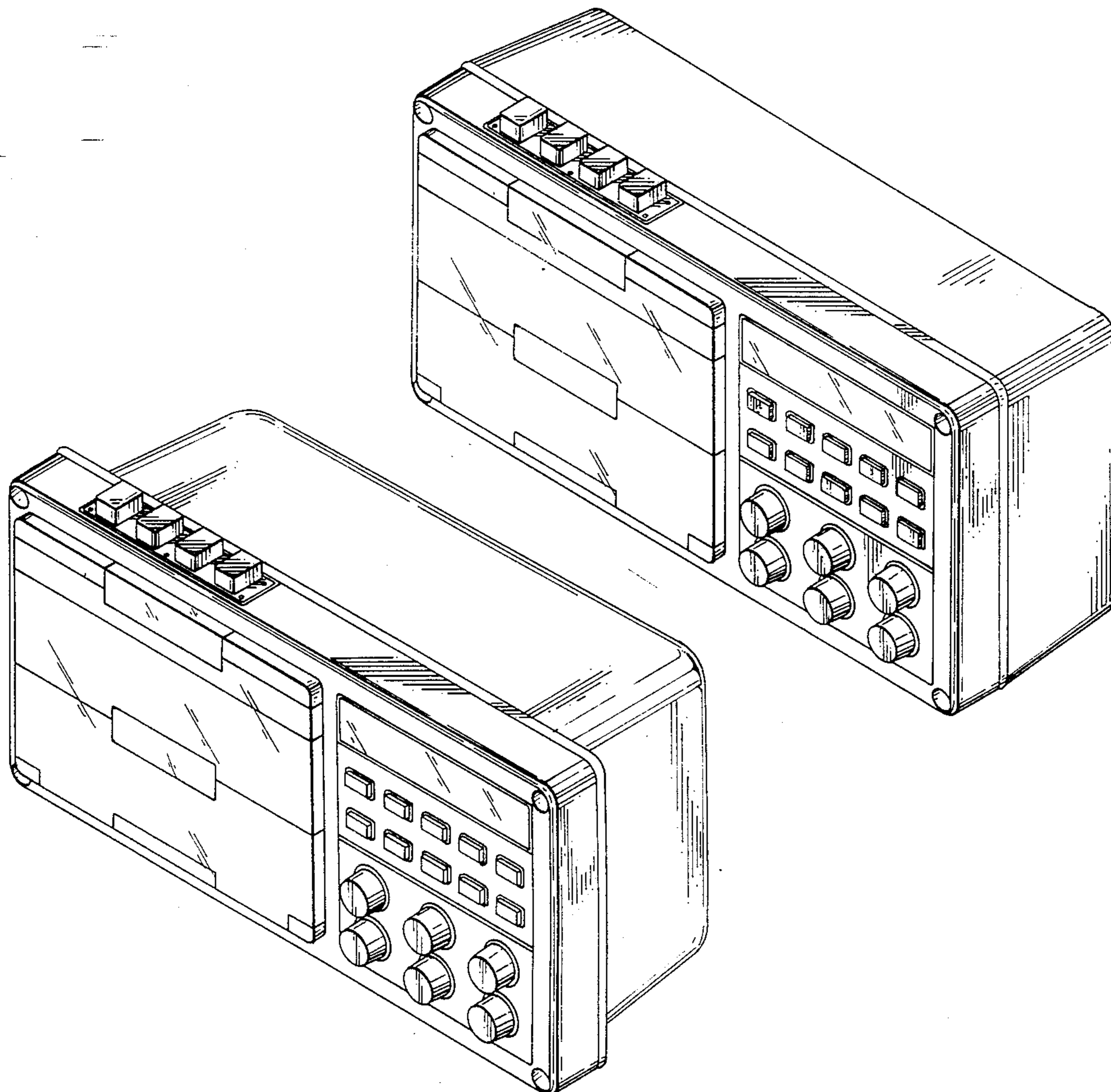
Primary Examiner—Theodore M. Shooman  
Attorney, Agent, or Firm—St. Onge Steward Johnston & Reens

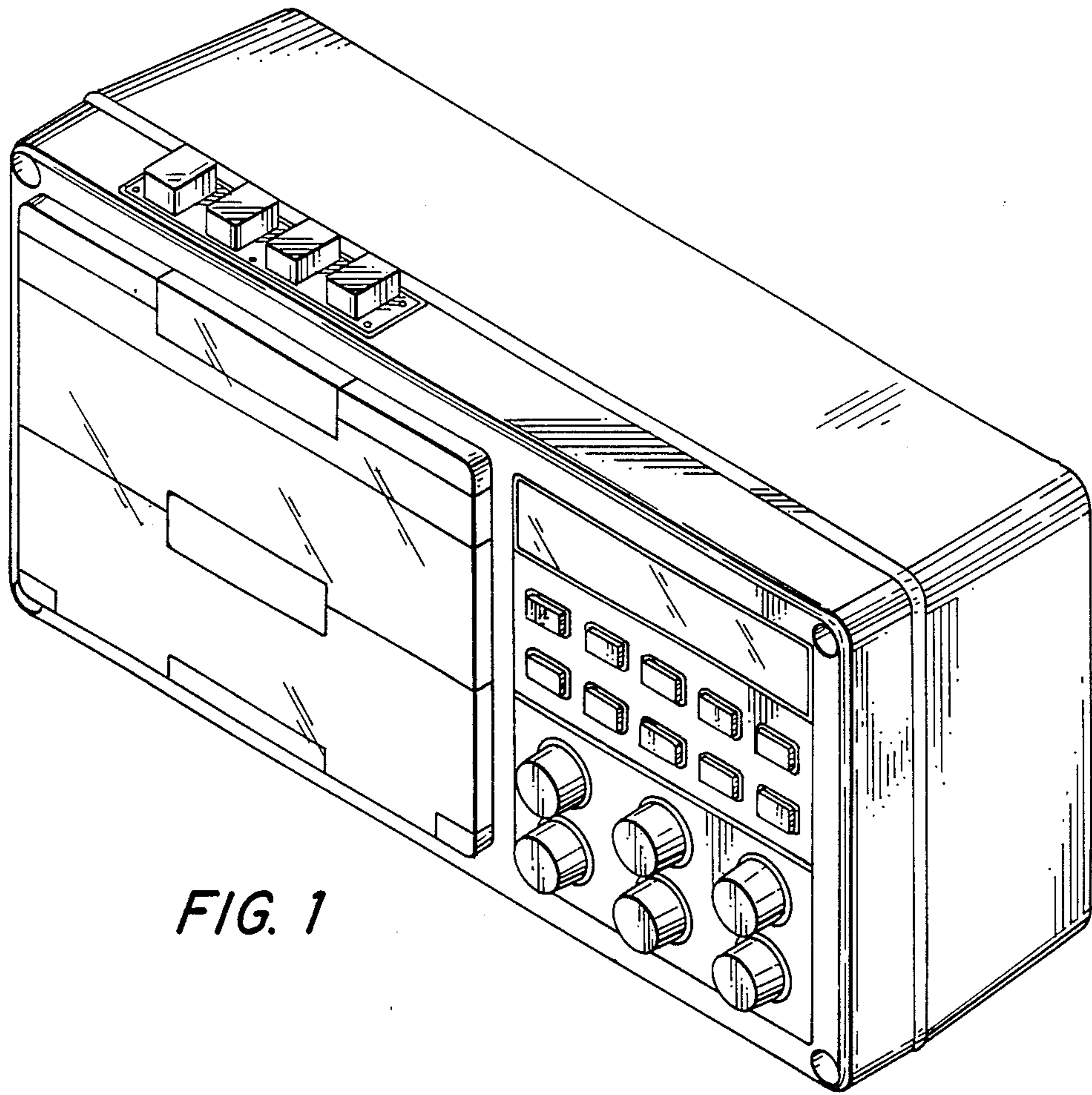
[57] CLAIM

The ornamental design for a marine radio, as shown and described.

DESCRIPTION

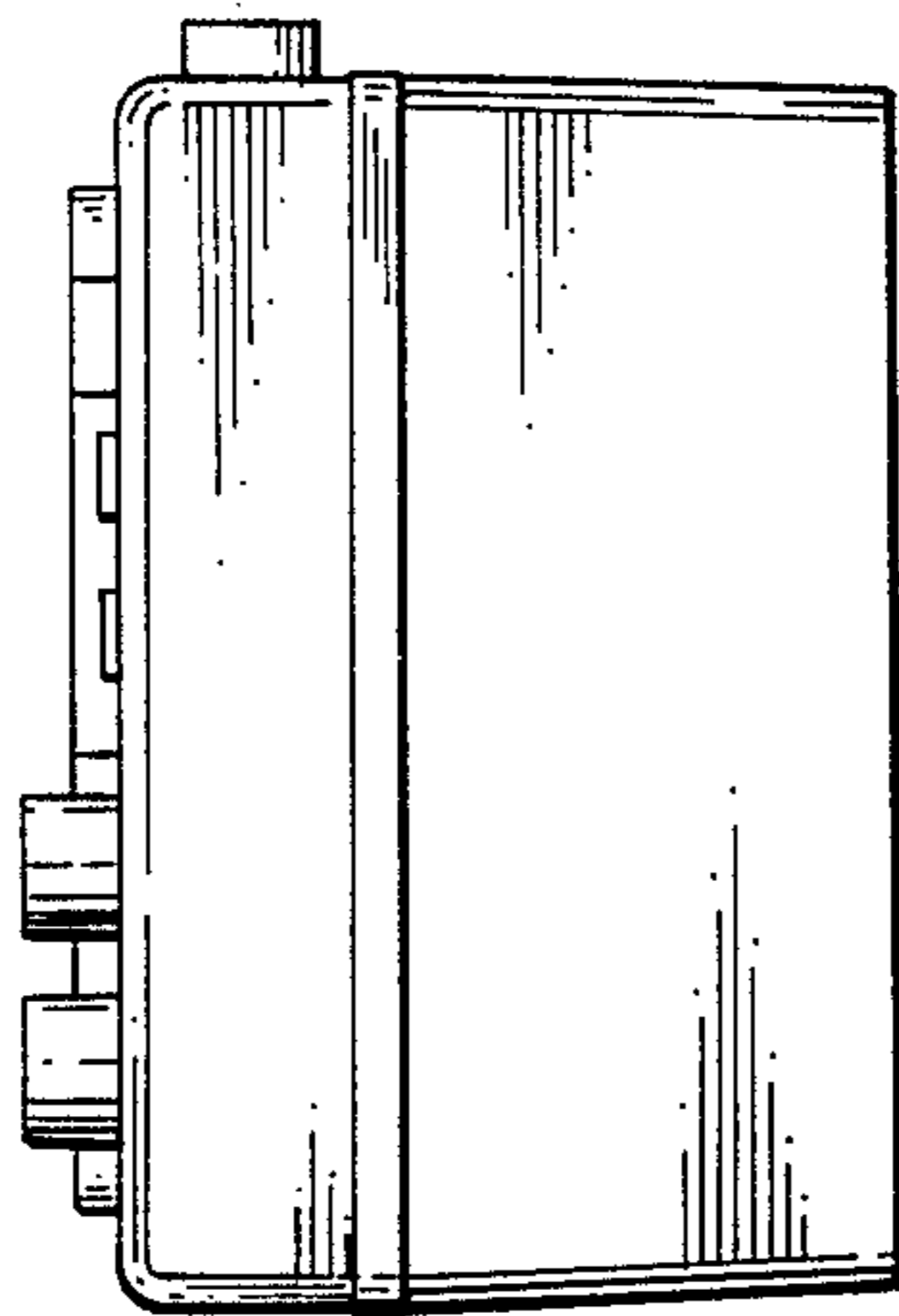
FIG. 1 is a top, front and right side perspective view of a marine radio showing our new design;  
 FIG. 2 is a right side elevational view thereof;  
 FIG. 3 is a left side elevational view thereof;  
 FIG. 4 is a bottom plan view thereof;  
 FIG. 5 is a top plan view thereof;  
 FIG. 6 is a top, front and right side perspective view of a second embodiment of the marine radio illustrated in FIG. 1;  
 FIG. 7 is a right side elevational view of the embodiment disclosed in FIG. 6;  
 FIG. 8 is a left side elevational view of the embodiment disclosed in FIG. 6;  
 FIG. 9 is a bottom plan view of the embodiment disclosed in FIG. 6; and  
 FIG. 10 is a top plan view of the embodiment disclosed in FIG. 6.  
 The rear of the marine radio is plane and unornamented.





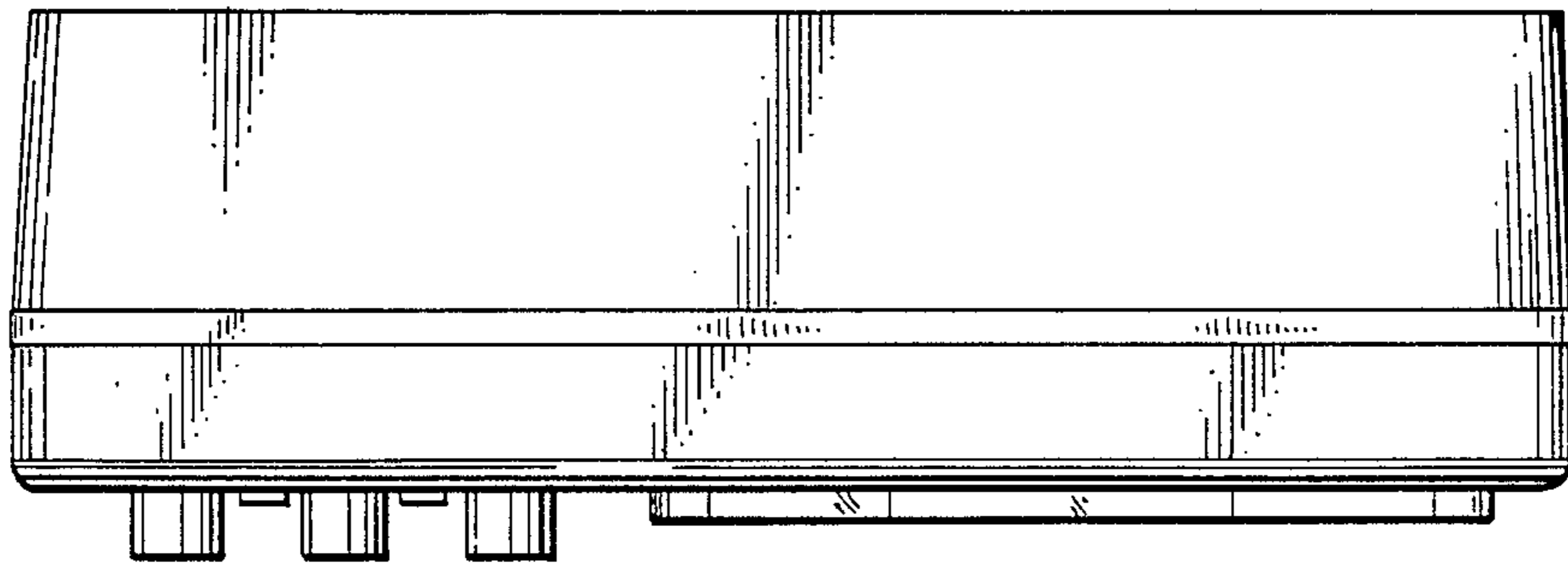
*FIG. 1*

*FIG. 2*

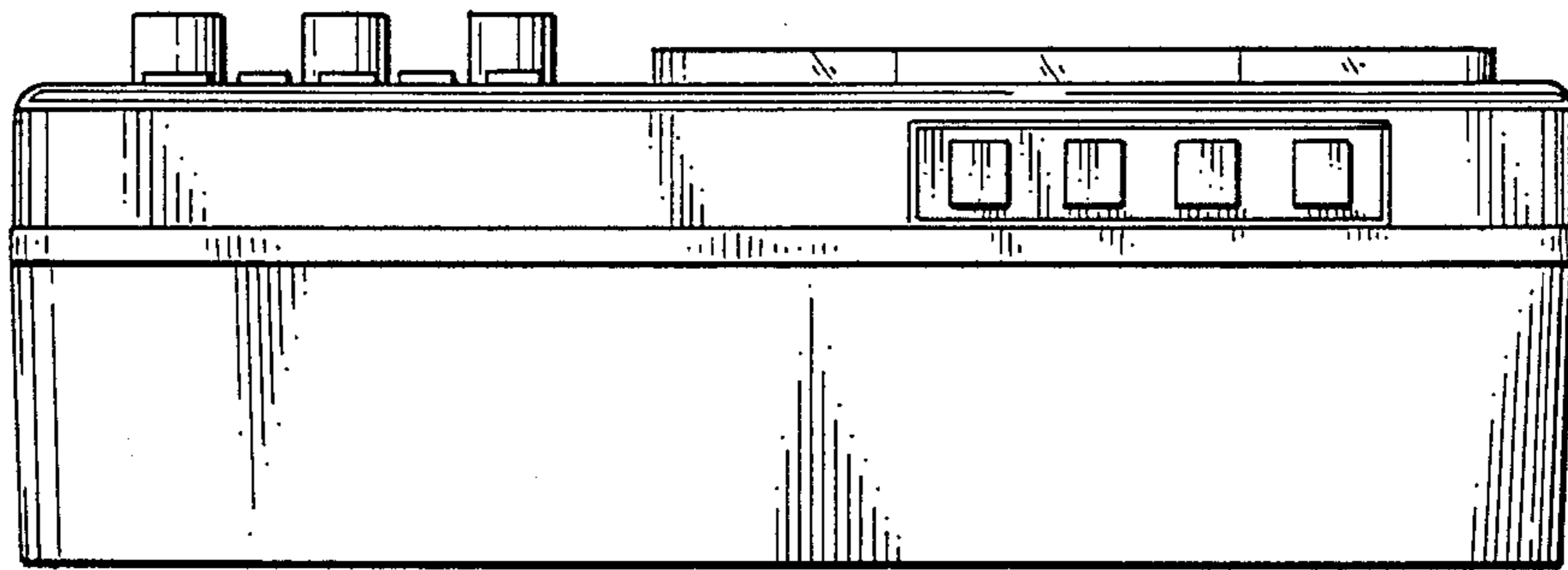


*FIG. 3*





*FIG. 4*



*FIG. 5*



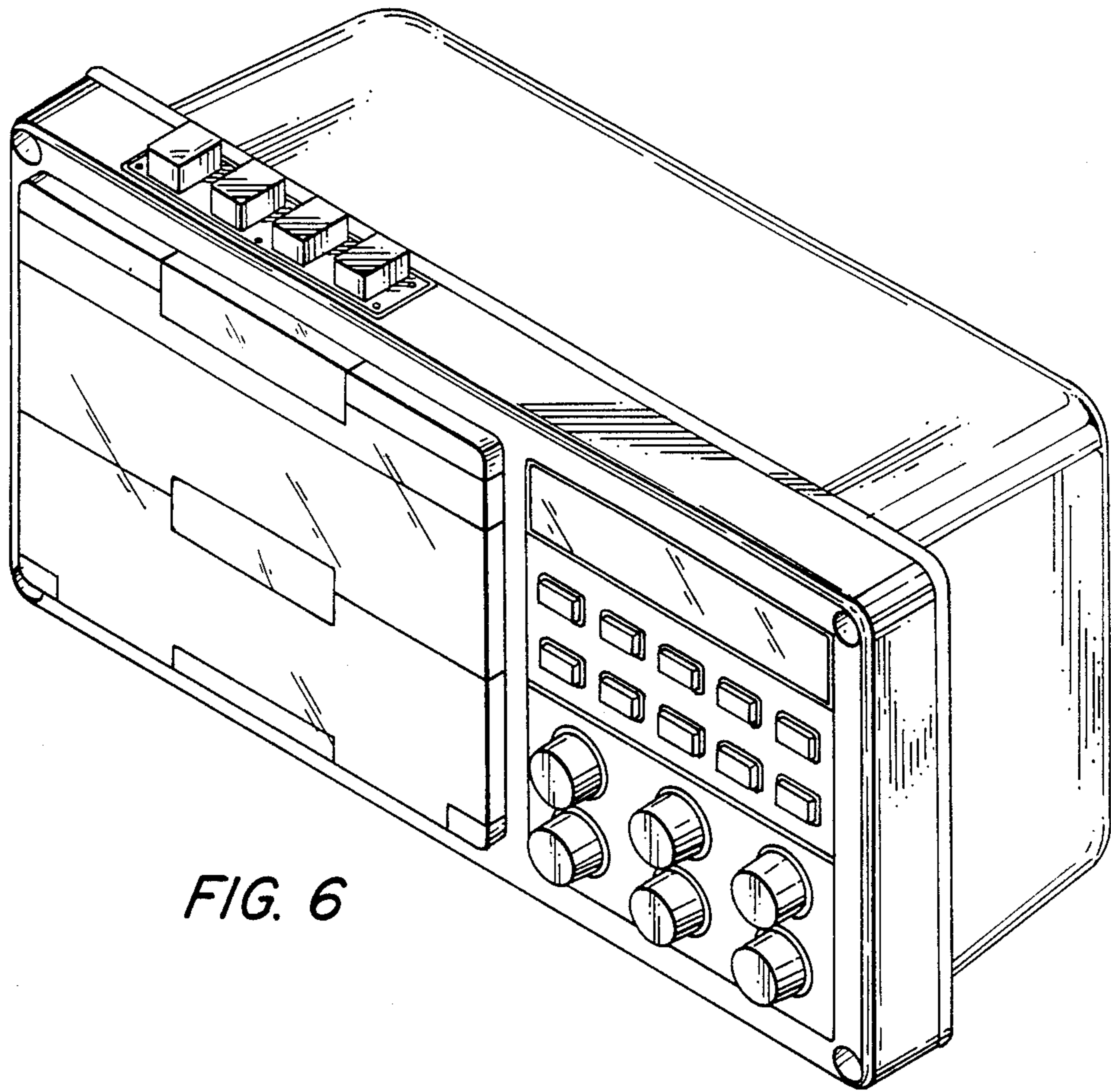


FIG. 6

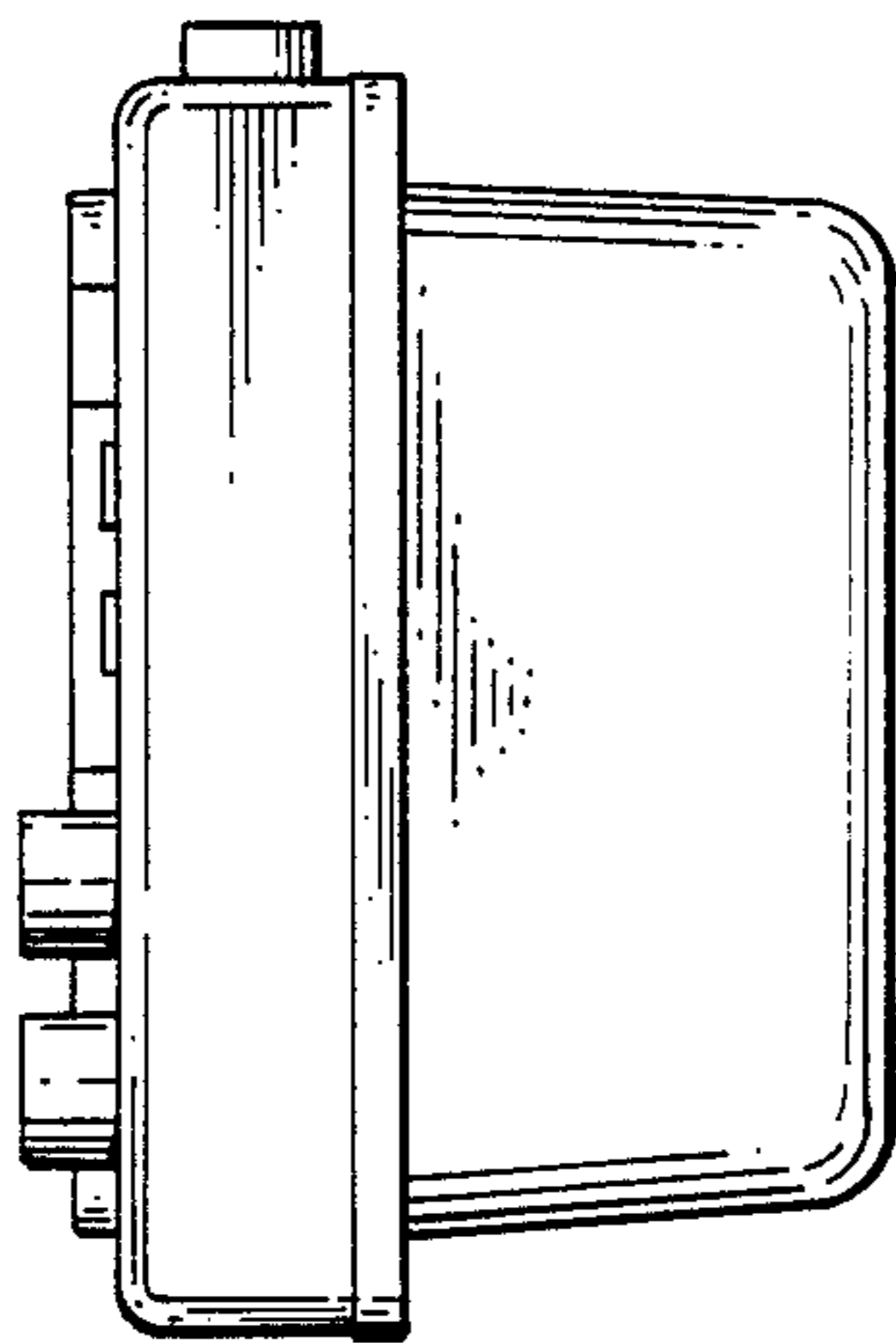


FIG. 7

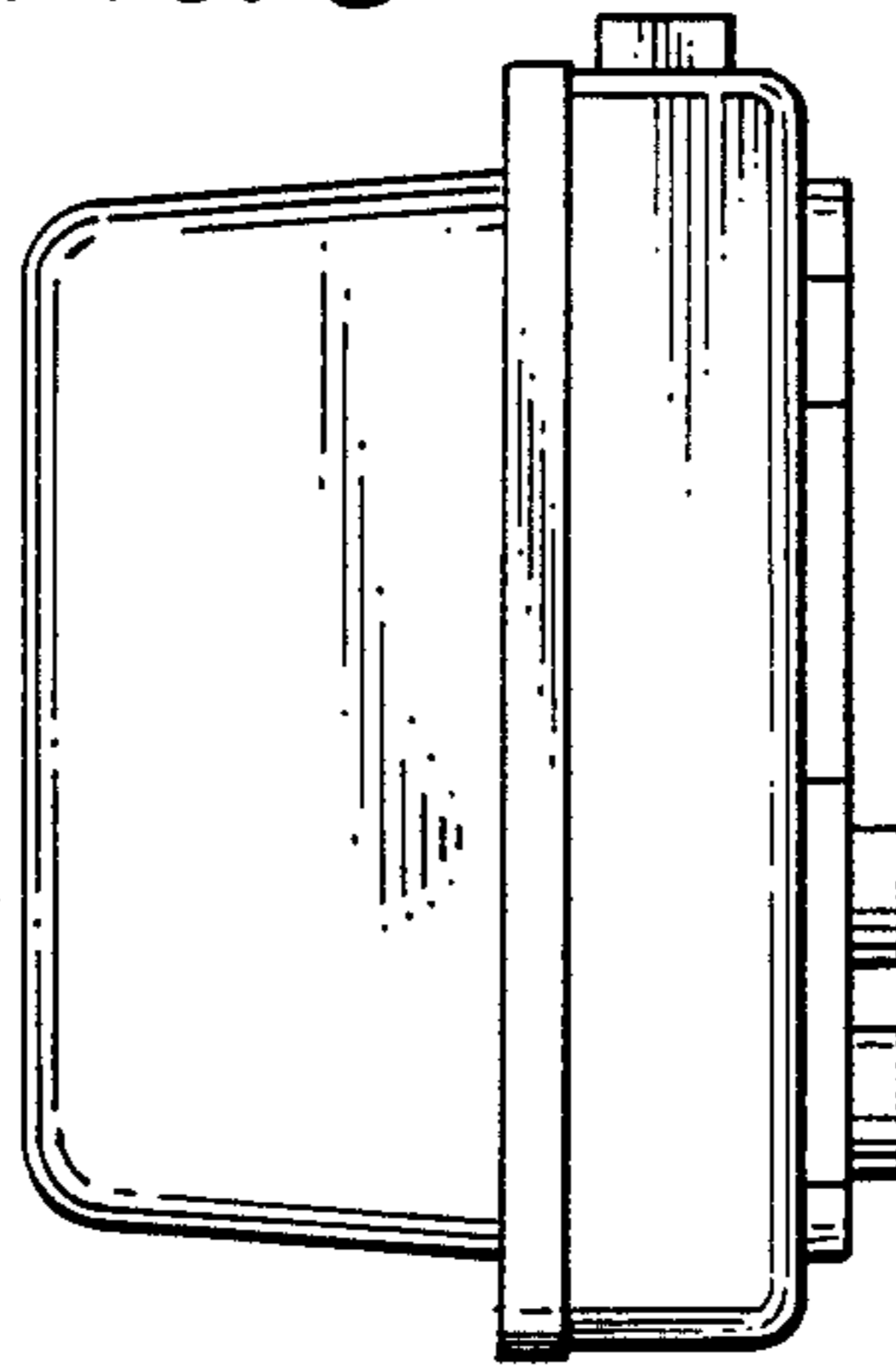


FIG. 8

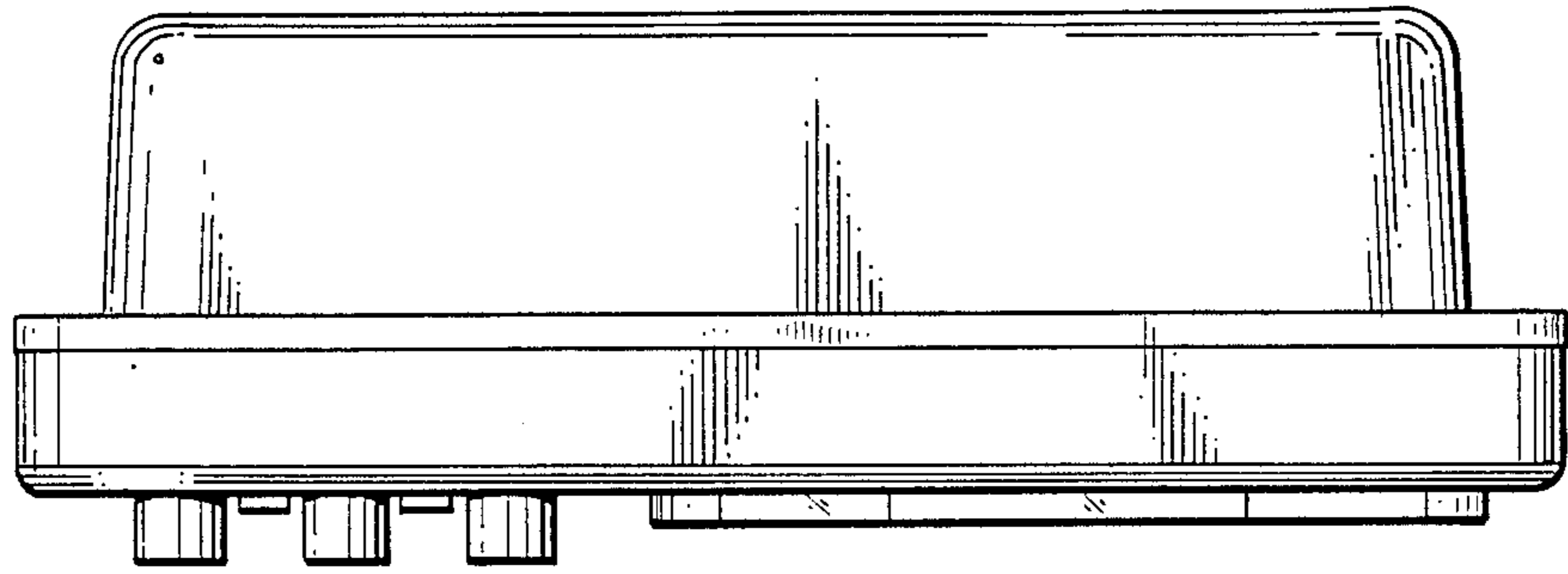


FIG. 9

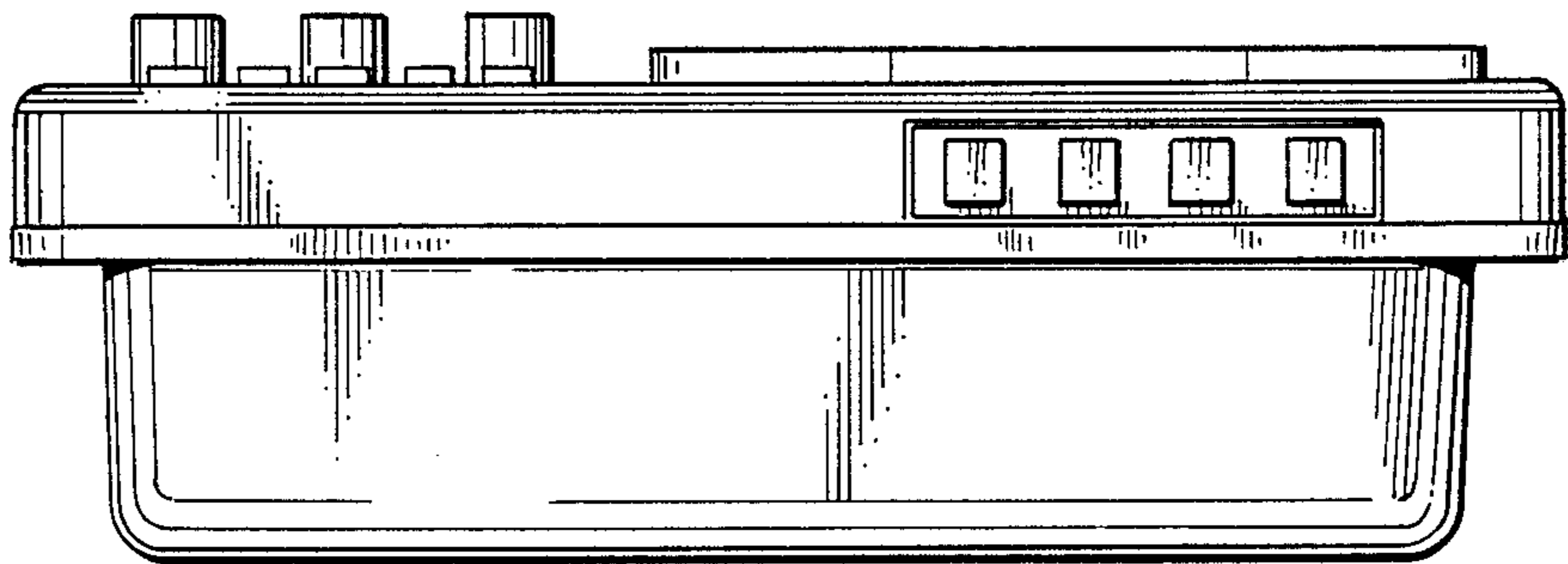


FIG. 10