

[54] BICYCLE MOUNTABLE GOLF CLUB RACK

[76] Inventor: Richard L. Lynch, 1047 Wellsville, Memphis, Tenn. 38117

[**] Term: 14 Years

[21] Appl. No.: 182,585

[22] Filed: Apr. 18, 1988

[52] U.S. Cl. D12/158

[58] Field of Search D12/158; 224/30 R, 32 R, 224/32 A, 39; D34/15; D3/37

[56] References Cited

U.S. PATENT DOCUMENTS

D. 277,285	1/1984	Gillett	D34/15
D. 302,886	8/1989	Podilla	D34/15
2,411,965	12/1946	Hartung	D34/15
2,758,848	8/1956	Christensen	D34/15
3,165,330	1/1965	Cotton	D34/15
3,172,687	3/1965	Moses	D34/15
4,194,547	3/1980	Sidor et al.	D3/37
4,770,326	9/1988	Thompson	224/32 A

OTHER PUBLICATIONS

Holiday Magazine, Nov. 1948, p. 13, Hughes-Patent Pipe Organ Golf Bag.

Primary Examiner—James M. Gandy

Assistant Examiner—Melody Brown
Attorney, Agent, or Firm—Walker & McKenzie

[57] CLAIM

The ornamental design for a bicycle mountable golf club rack, as shown and described.

DESCRIPTION

FIG. 1 is a front side elevation view of a bicycle mountable golf club rack showing my new design; FIG. 2 is an end elevation view thereof; the opposite end being a mirror image of that shown; FIG. 3 is a rear side elevation view thereof; FIG. 4 is a bottom plan view thereof; FIG. 5 is a top plan view thereof; FIG. 6 is a front elevation view thereof on a reduced scale mounted on a bicycle which has been fragmentary shown in broken lines for illustrative purposes only and forms no part of the claimed design; FIG. 7 is an end elevation view of FIG. 6 with the additional golf club rack and golf clubs shown in broken lines for illustrative purposes only; FIG. 8 is a front elevation view of a bicycle mountable golf club rack mounted on a bicycle as in FIG. 6 showing a second embodiment of my new design wherein the sole difference resides in the addition of an integral parking stand; and FIG. 9 is an end elevation view of FIG. 8 showing an additional golf club rack in broken lines as in FIG. 7.

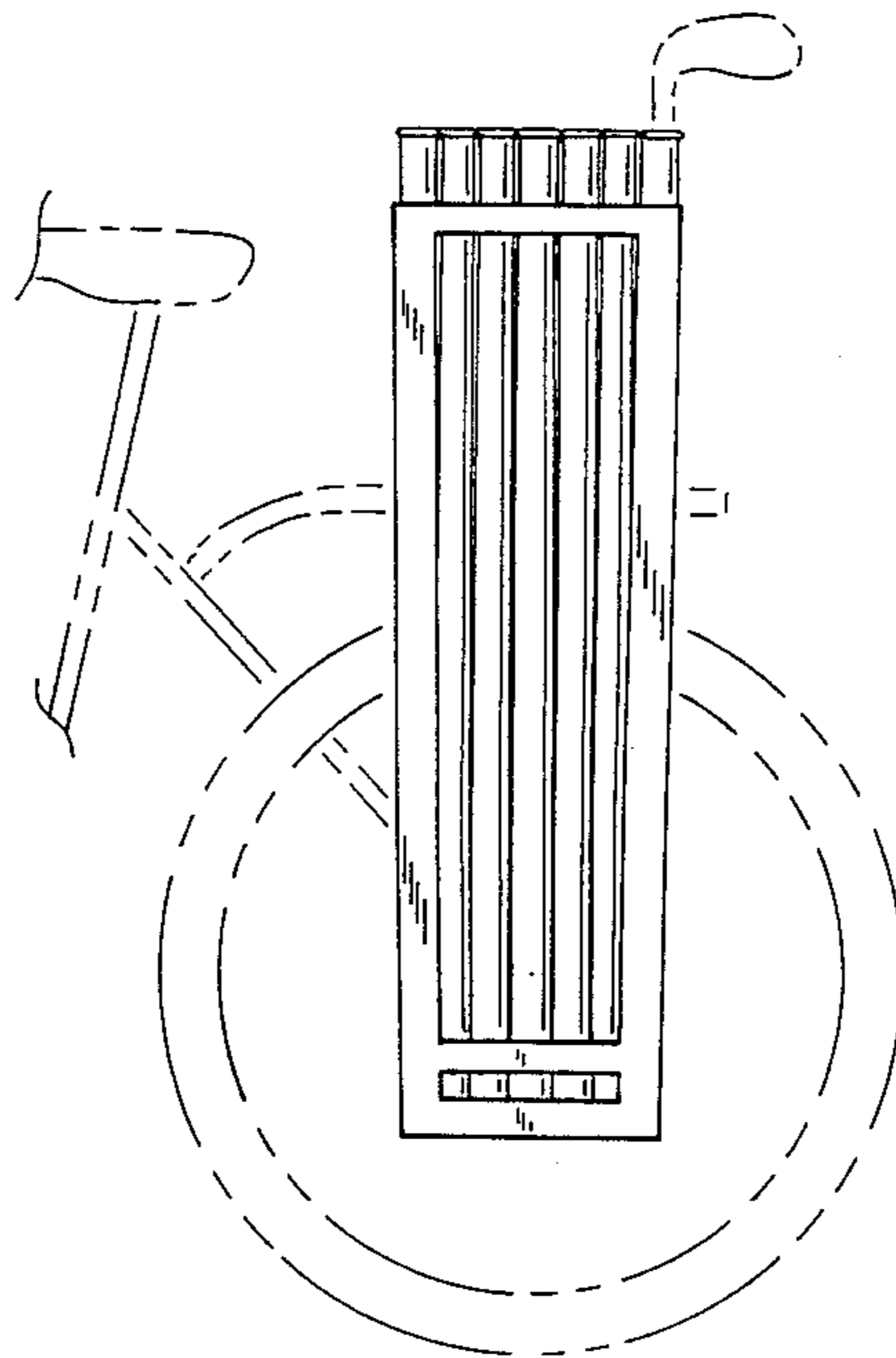

FIG. 1

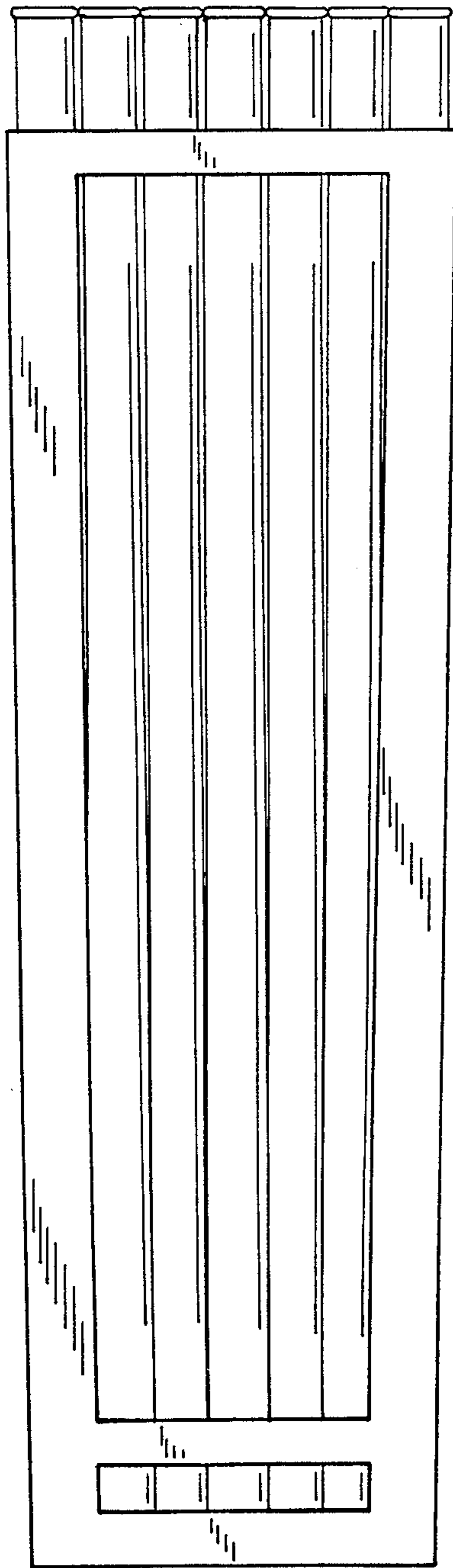

FIG. 2



FIG. 3

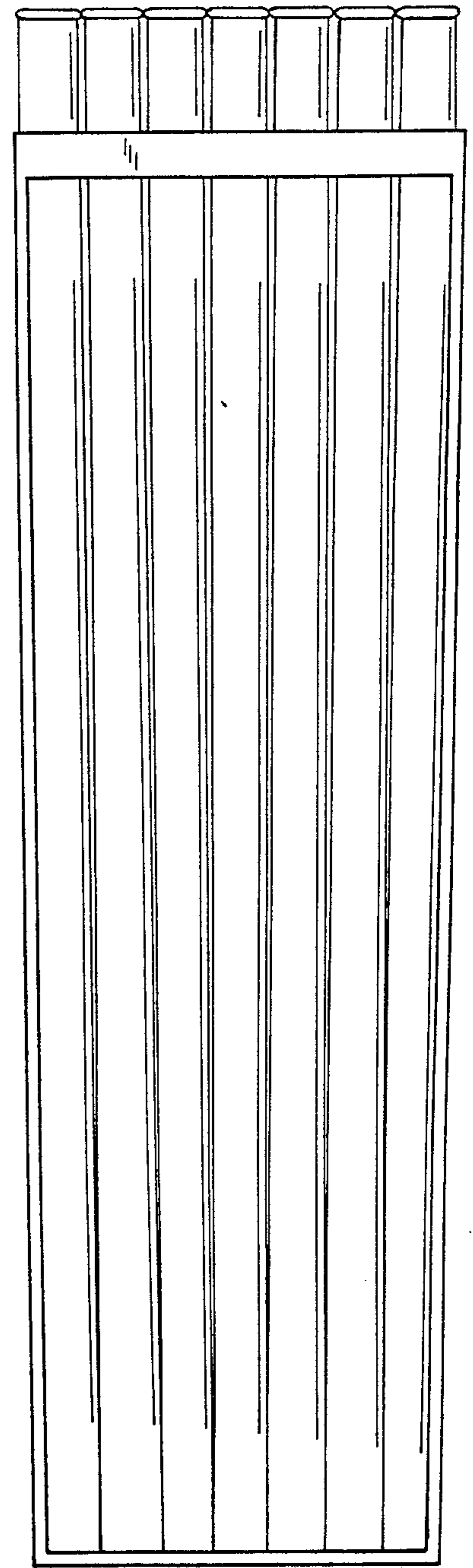

FIG. 4



FIG. 5



FIG. 6

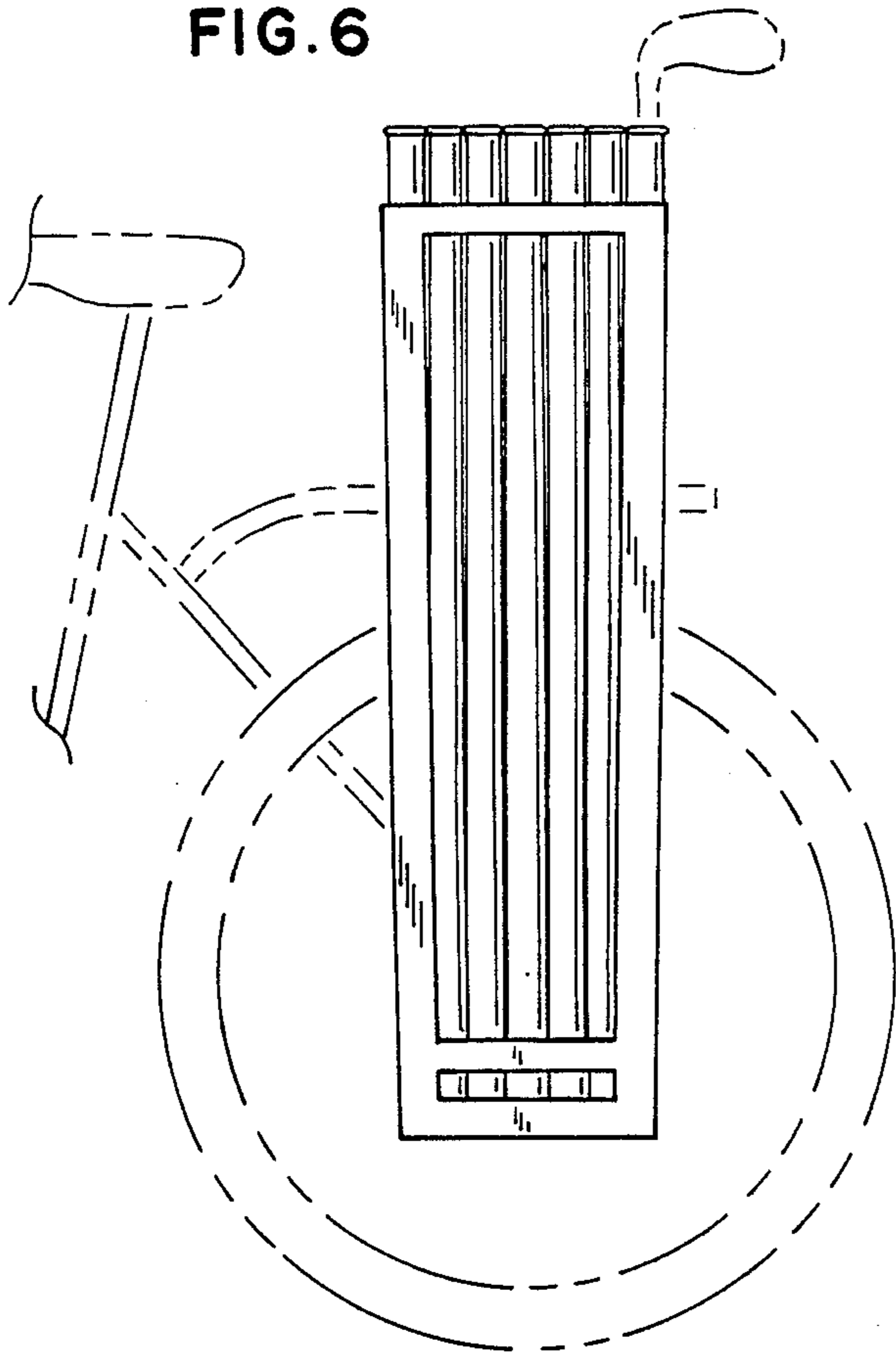

FIG. 7

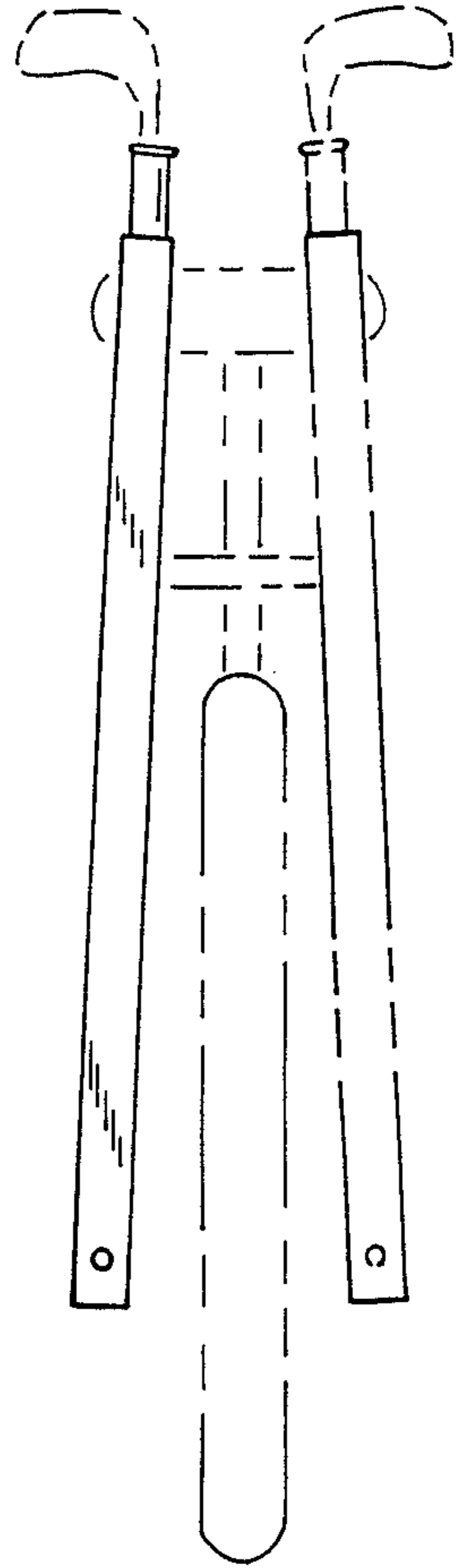

FIG. 8

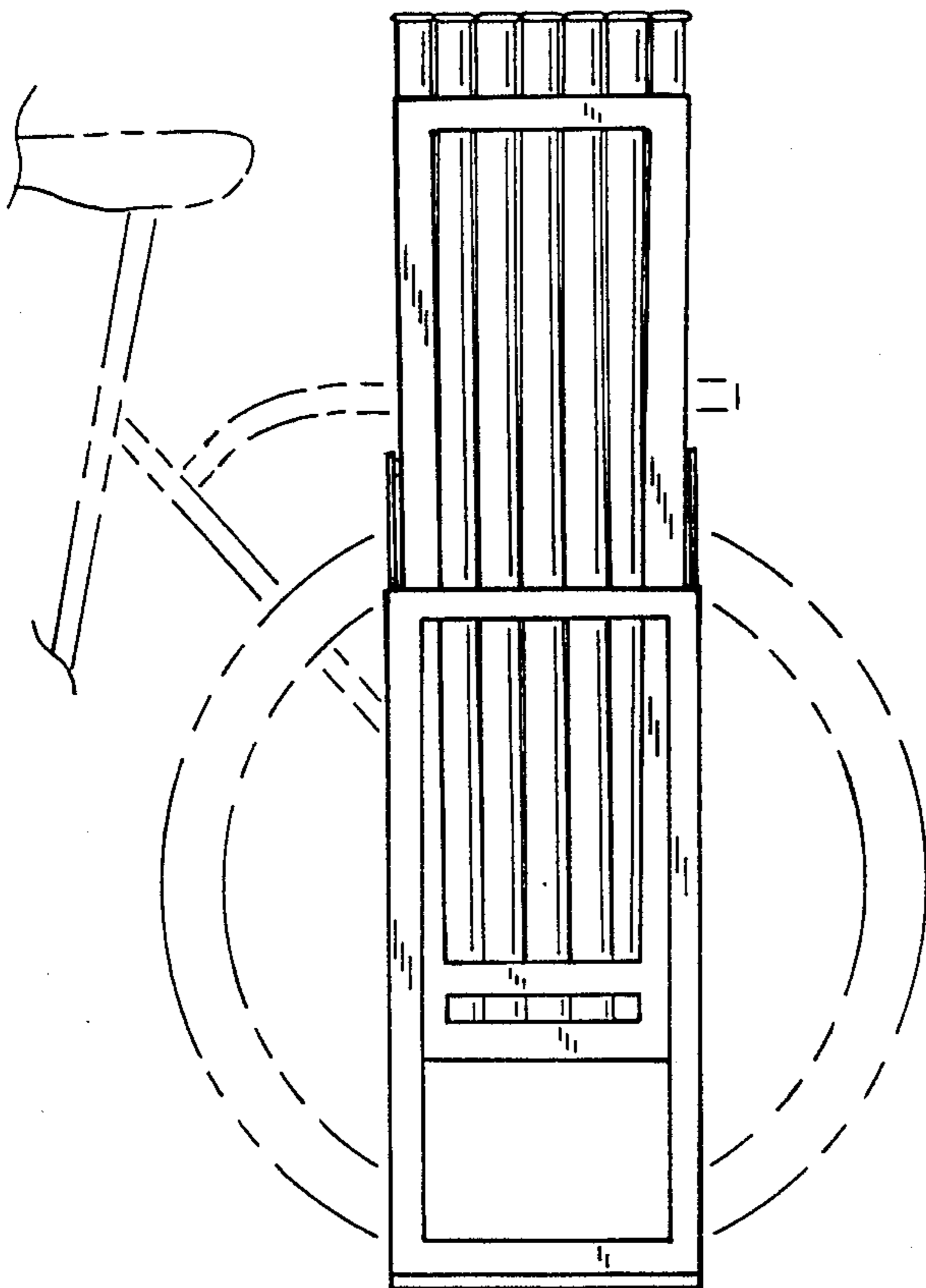

FIG. 9

