

[54] TRICYCLE

[76] Inventors: Richard L. Koehler, P.O. Box 566, St. James City, Fla. 33956; Willie E. Koehler, both of 7632 Ivywood Dr., Indianapolis, Ind. 46250

[\*\*] Term: 14 Years

[21] Appl. No.: 114,383

[22] Filed: Oct. 30, 1987

[52] U.S. Cl. .... D12/112

[58] Field of Search ..... D12/112, 113; 280/202, 280/231, 282

[56] References Cited

U.S. PATENT DOCUMENTS

D. 126,663	4/1941	Niblack	.....	D12/113
D. 242,441	11/1976	Nagle	.....	D12/112
D. 253,101	10/1979	Pivar	.....	D12/112
D. 254,968	5/1980	Moore et al.	.....	D12/112
D. 268,923	5/1983	Mann	.....	D12/112

Primary Examiner—James M. Gandy

Attorney, Agent, or Firm—Woodard, Emhardt, Naughton, Moriarty & McNett

[57] CLAIM

The ornamental design for a tricycle, as shown and described.

DESCRIPTION

FIG. 1 is a front elevation view of a tricycle showing our new design.  
 FIG. 2 is a right side elevation view thereof.  
 FIG. 3 is a rear elevation view thereof.  
 FIG. 4 is a left side elevation view thereof with the seat compartment in open condition.  
 FIG. 5 is a top plan view thereof.  
 FIG. 6 is a bottom plan view thereof.  
 FIG. 7 is a front elevation view of a tricycle showing a second embodiment of our new design.  
 FIG. 8 is a right side elevation view of FIG. 7.  
 FIG. 9 is a rear elevation view of FIG. 7.  
 FIG. 10 is a left side elevation view of FIG. 7, with the seat compartment in open condition.  
 FIG. 11 is a top plan view of FIG. 7.  
 FIG. 12 is a bottom plan view of FIG. 7.

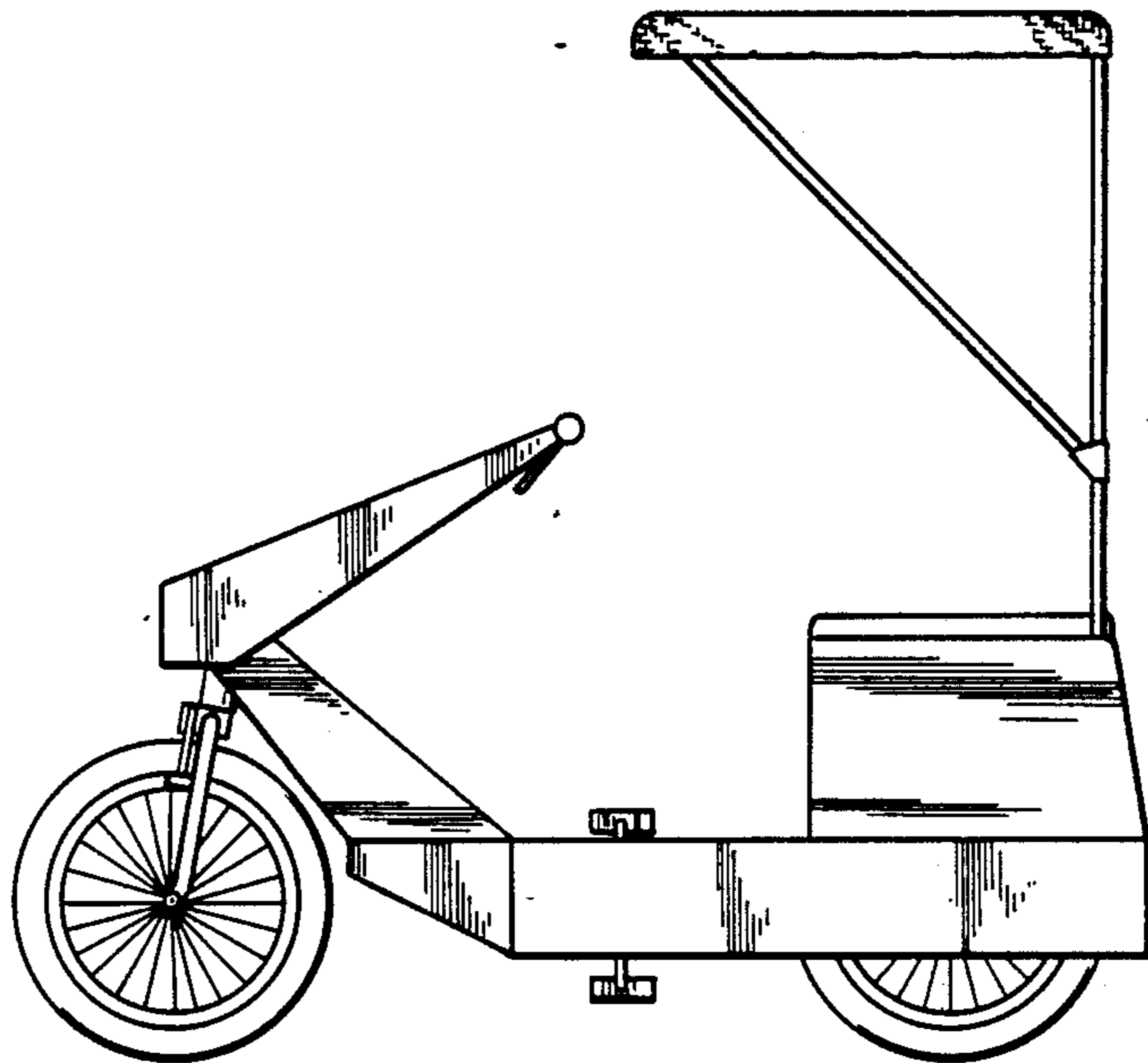
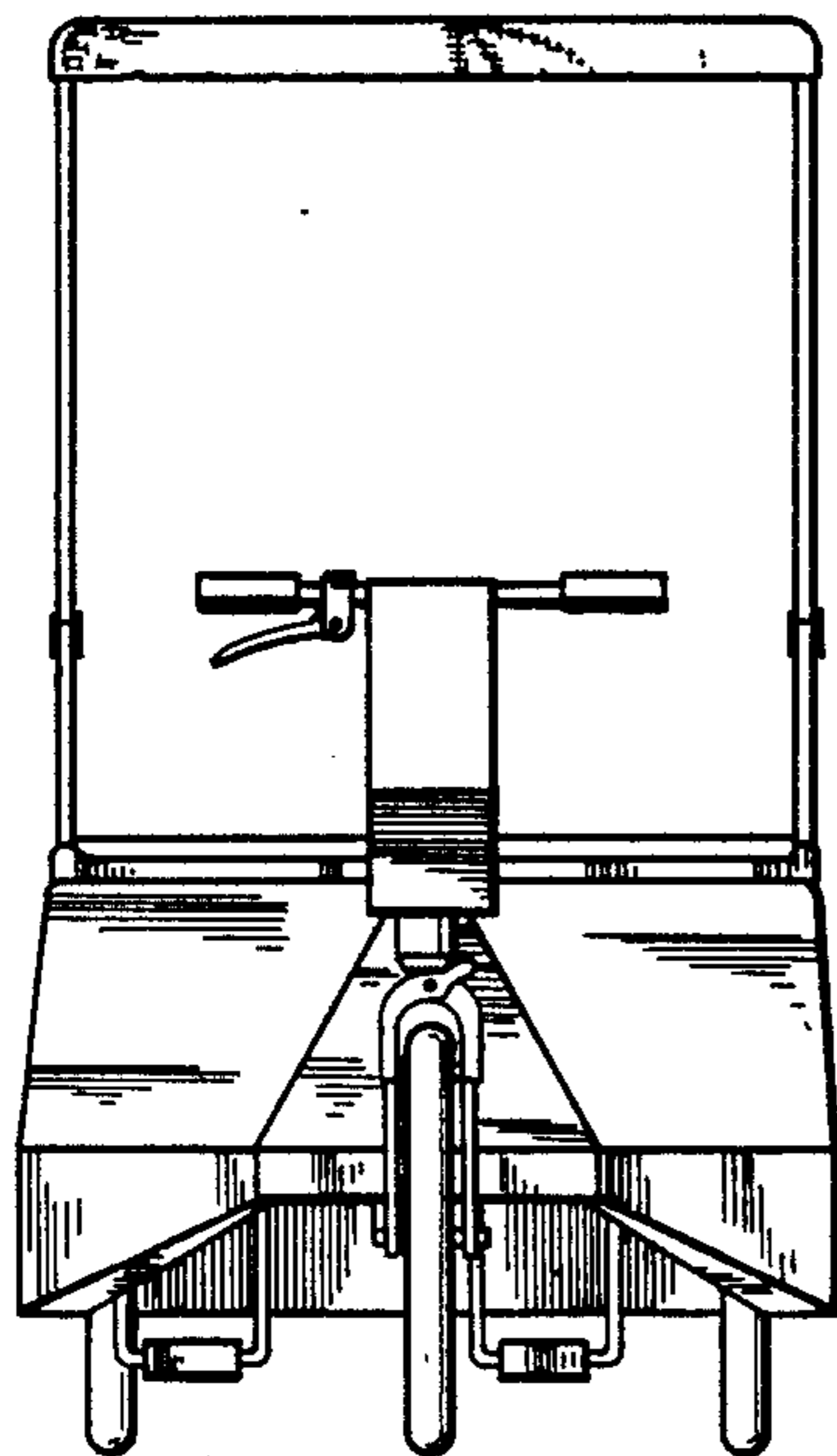

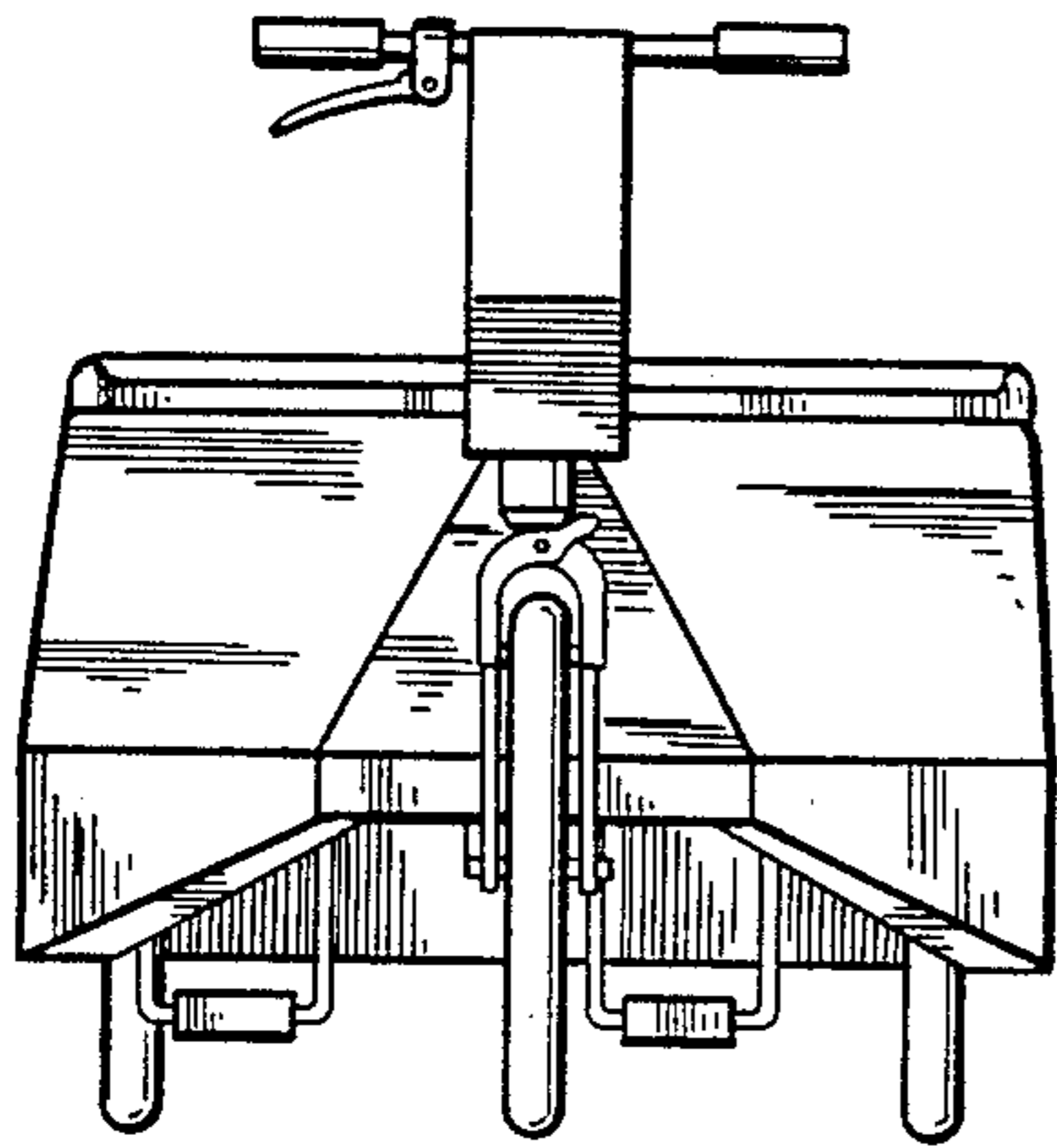

Fig. 1

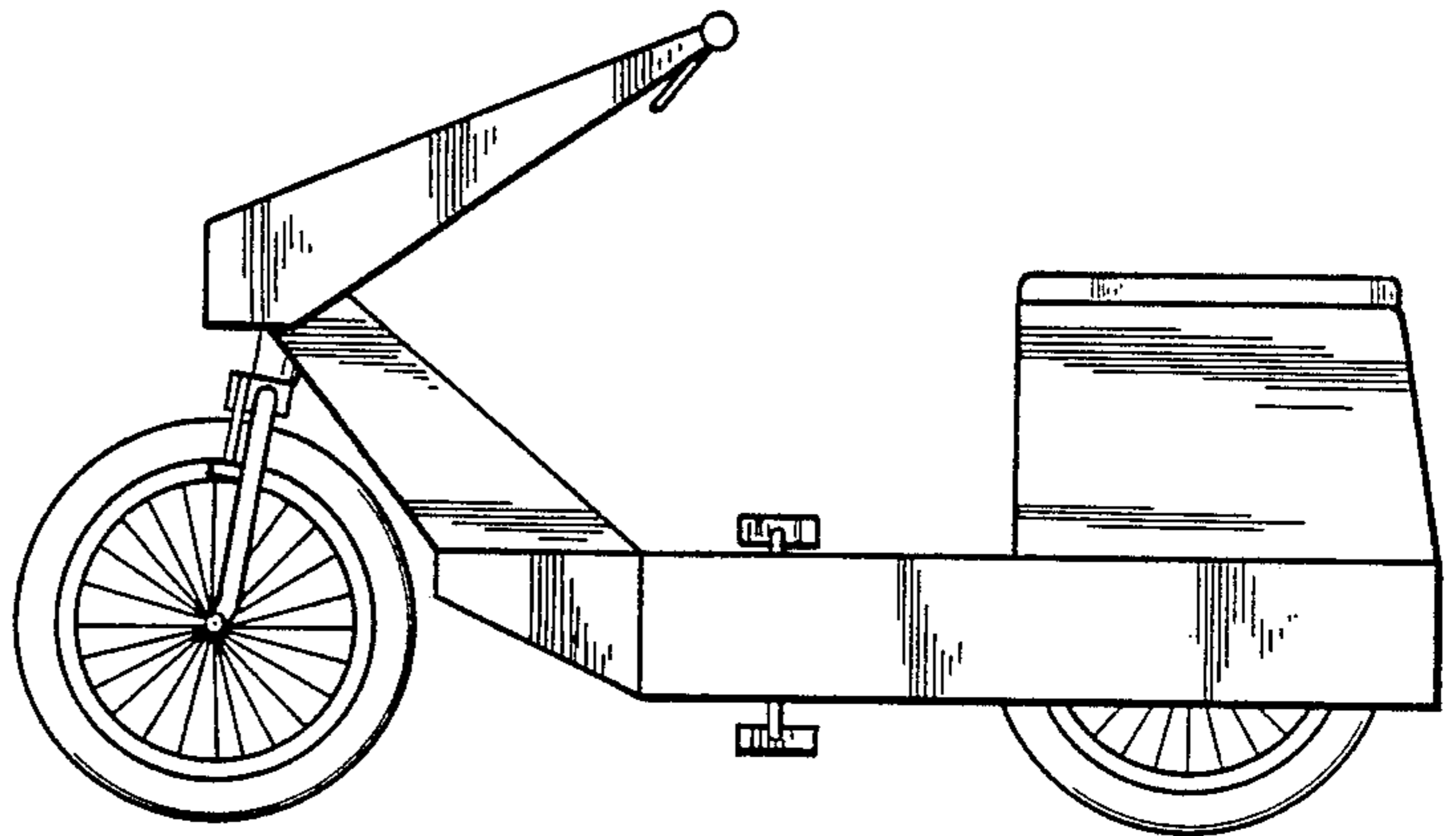

Fig. 2

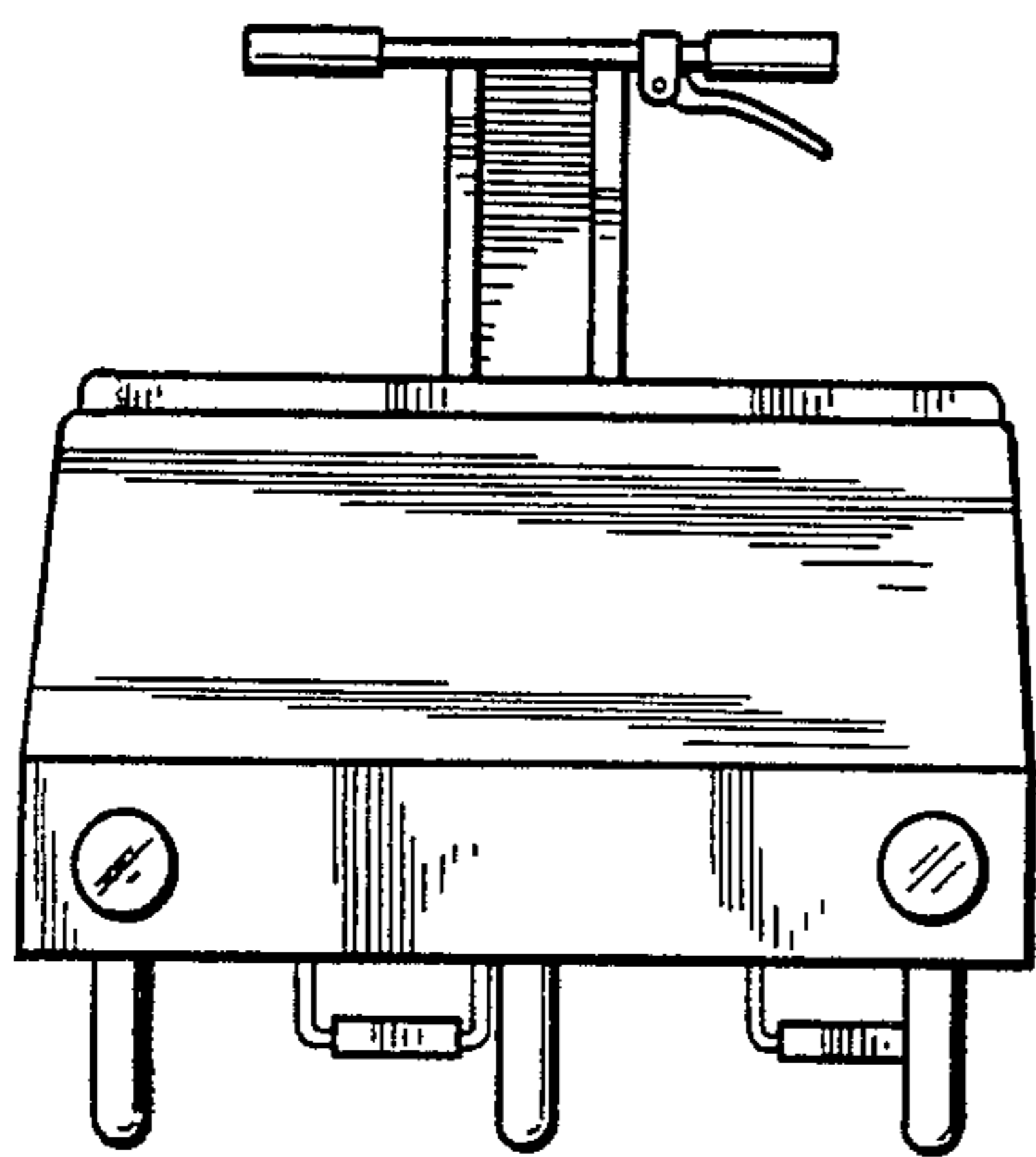

Fig. 3

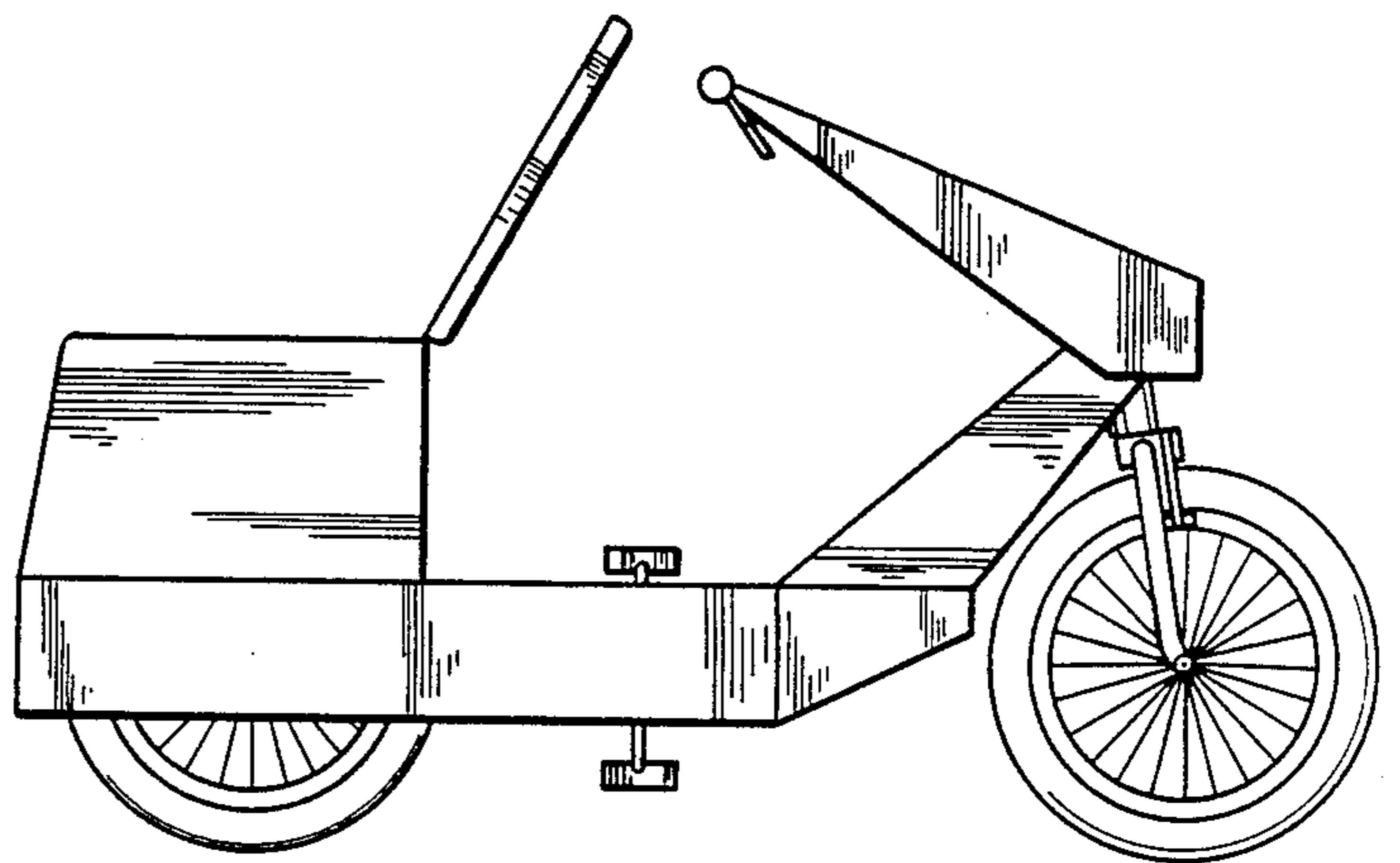

Fig. 4

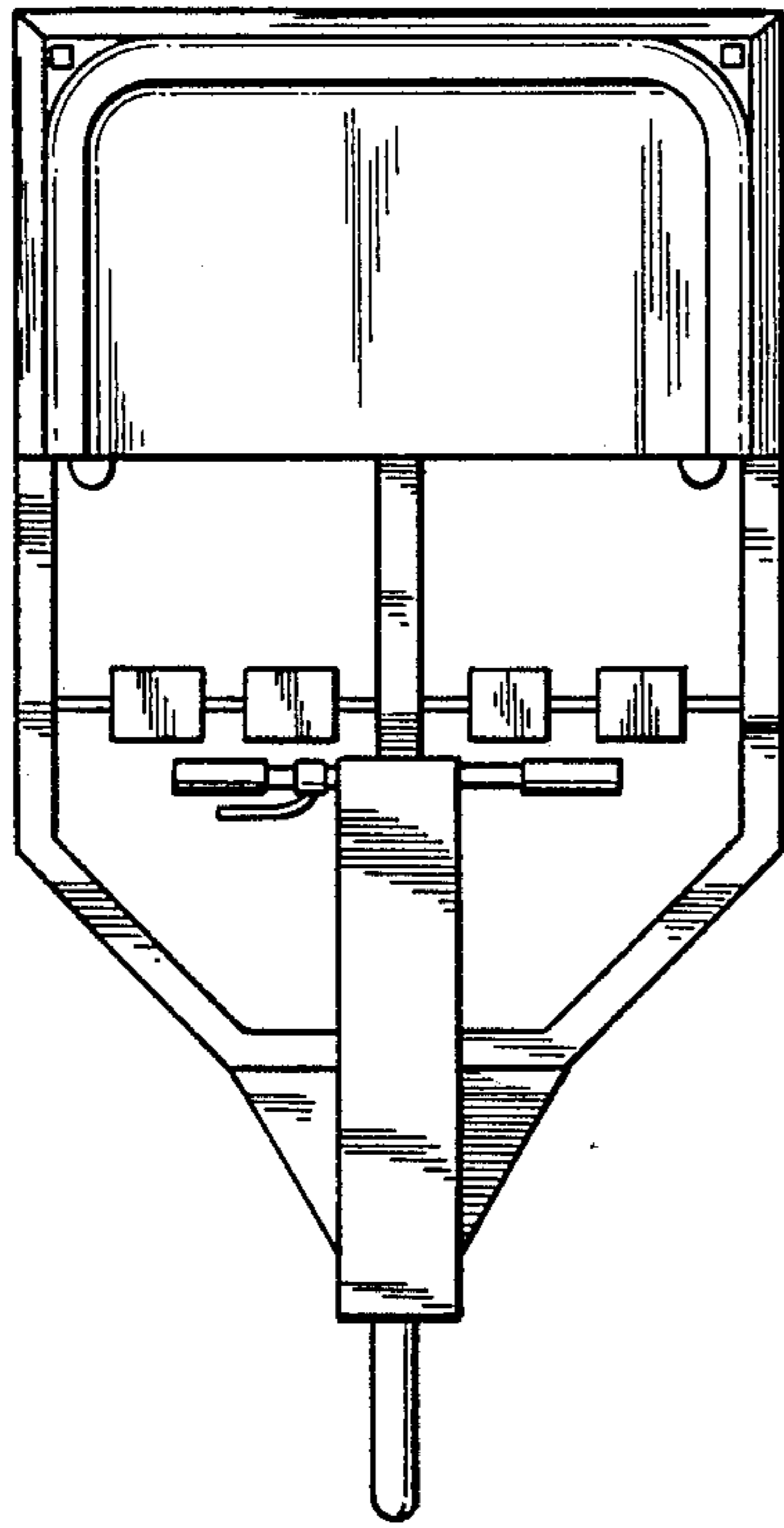

Fig. 5

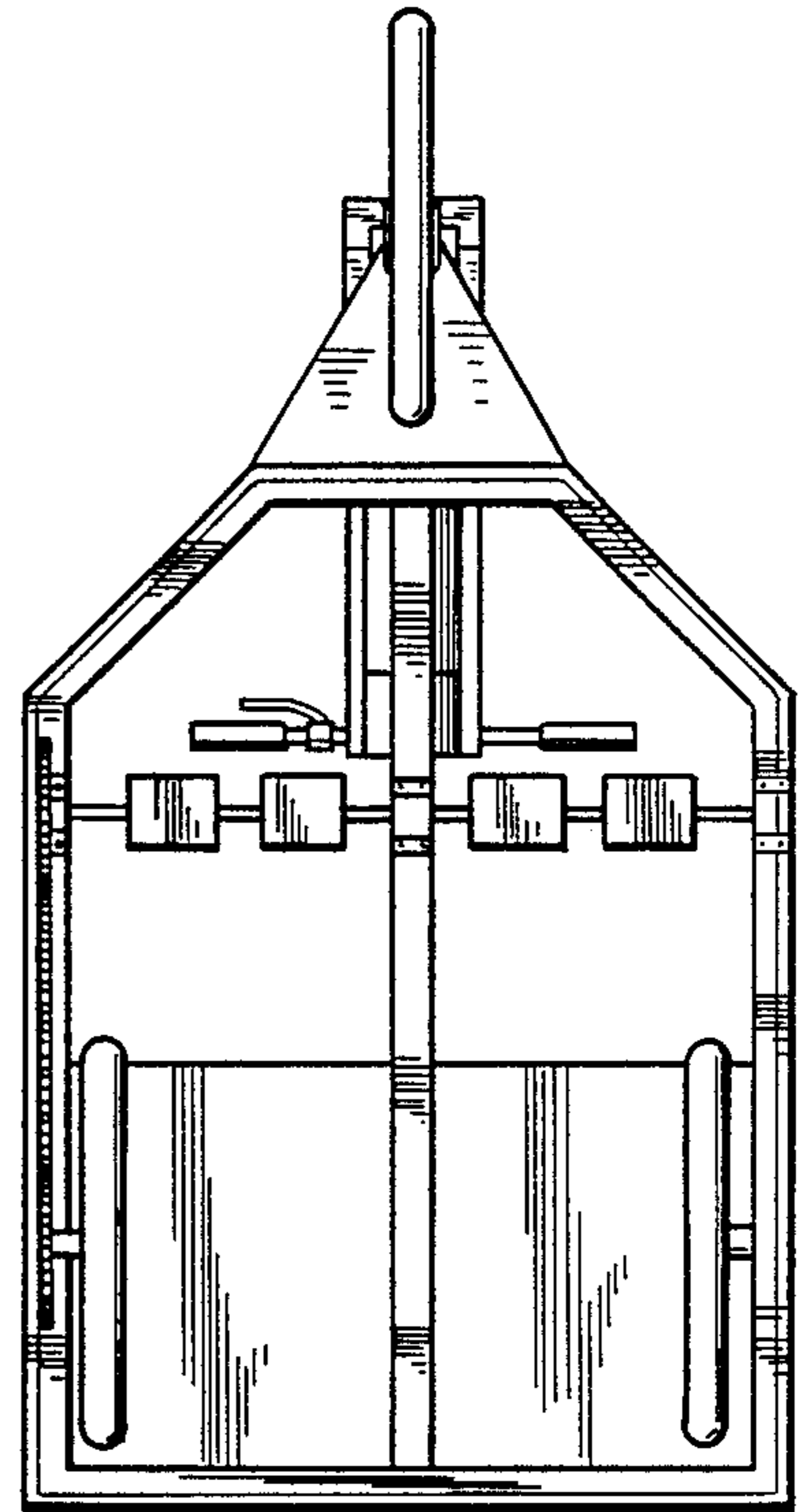

Fig. 6

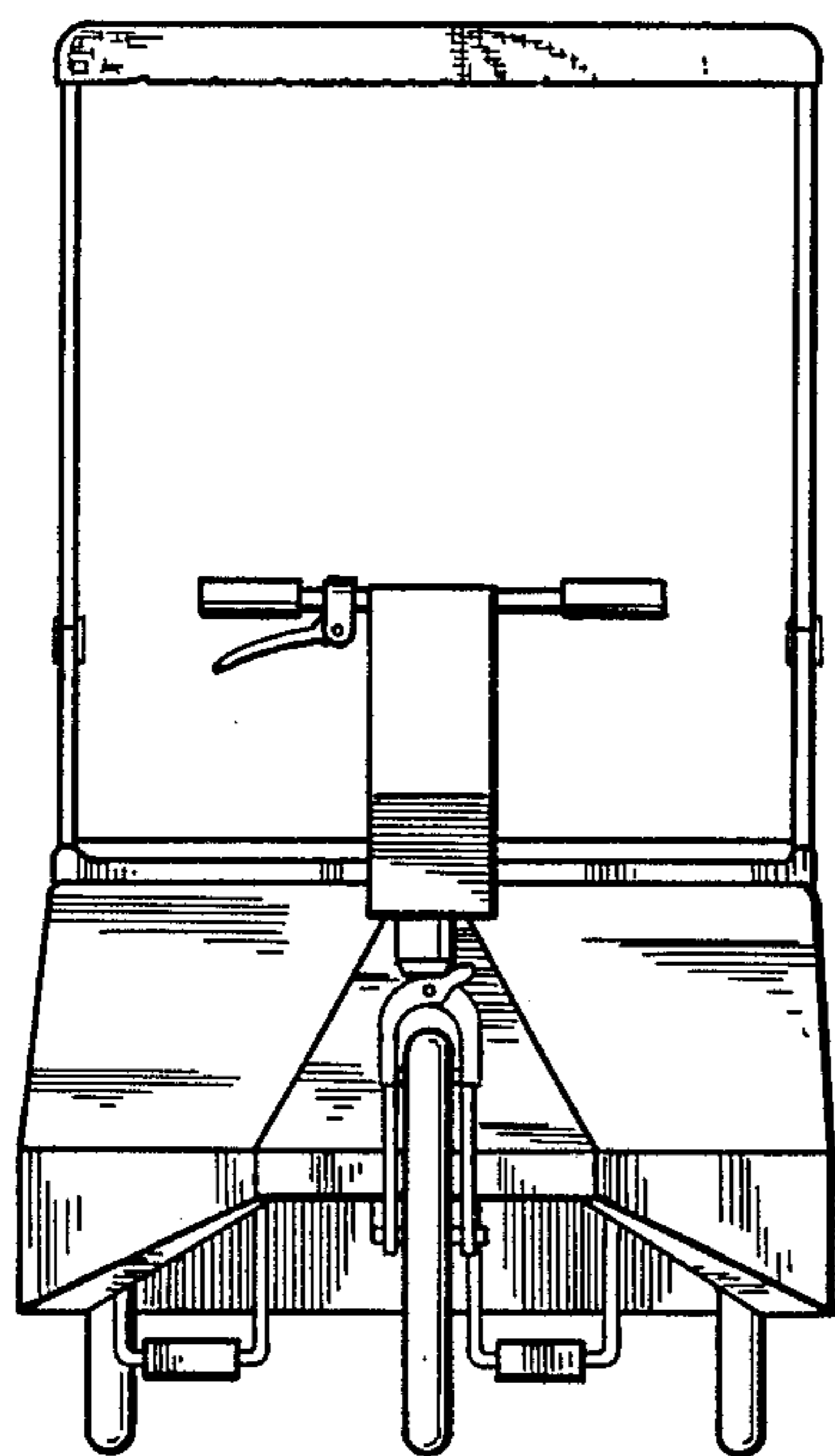

Fig. 7

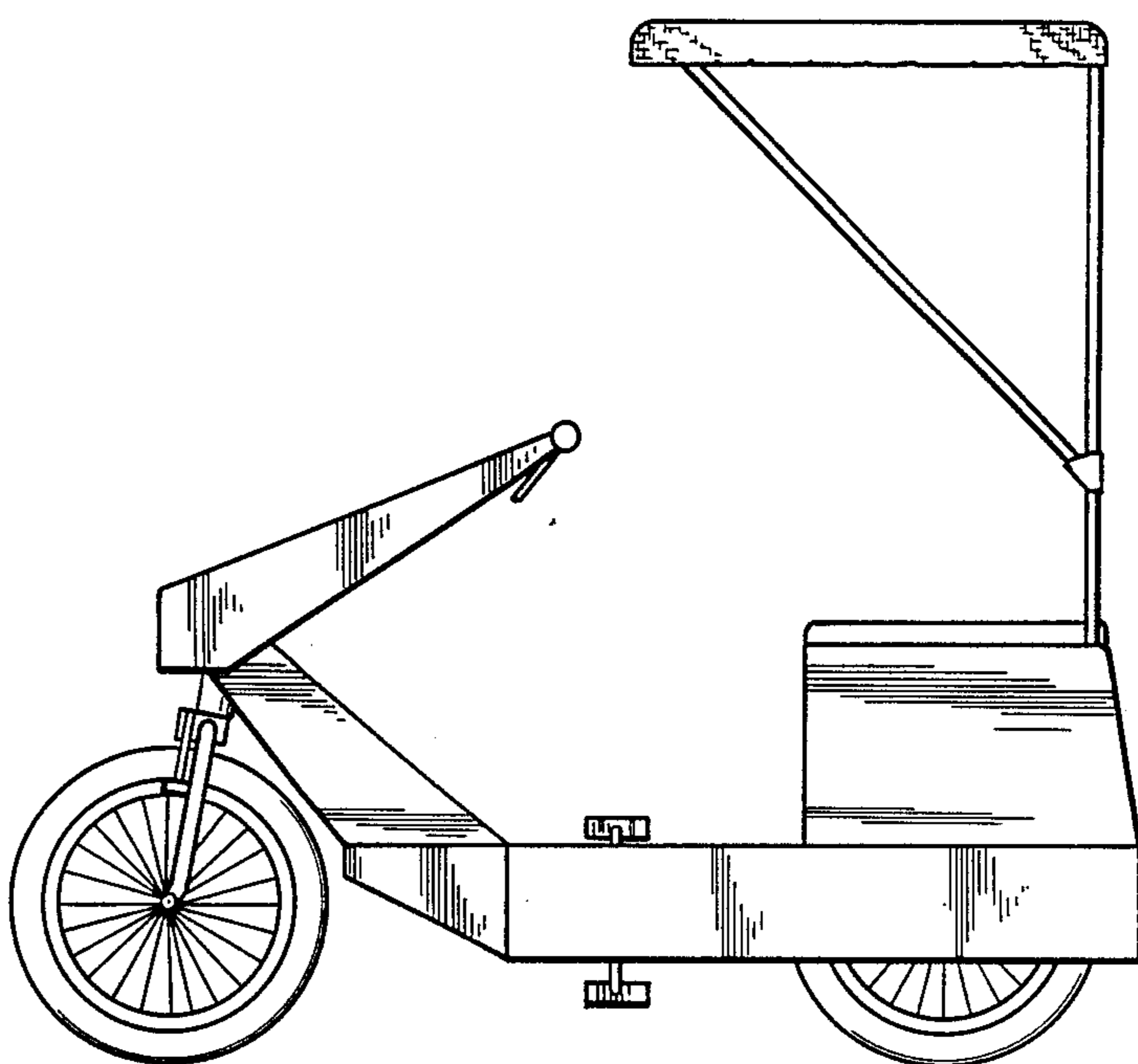

Fig. 8

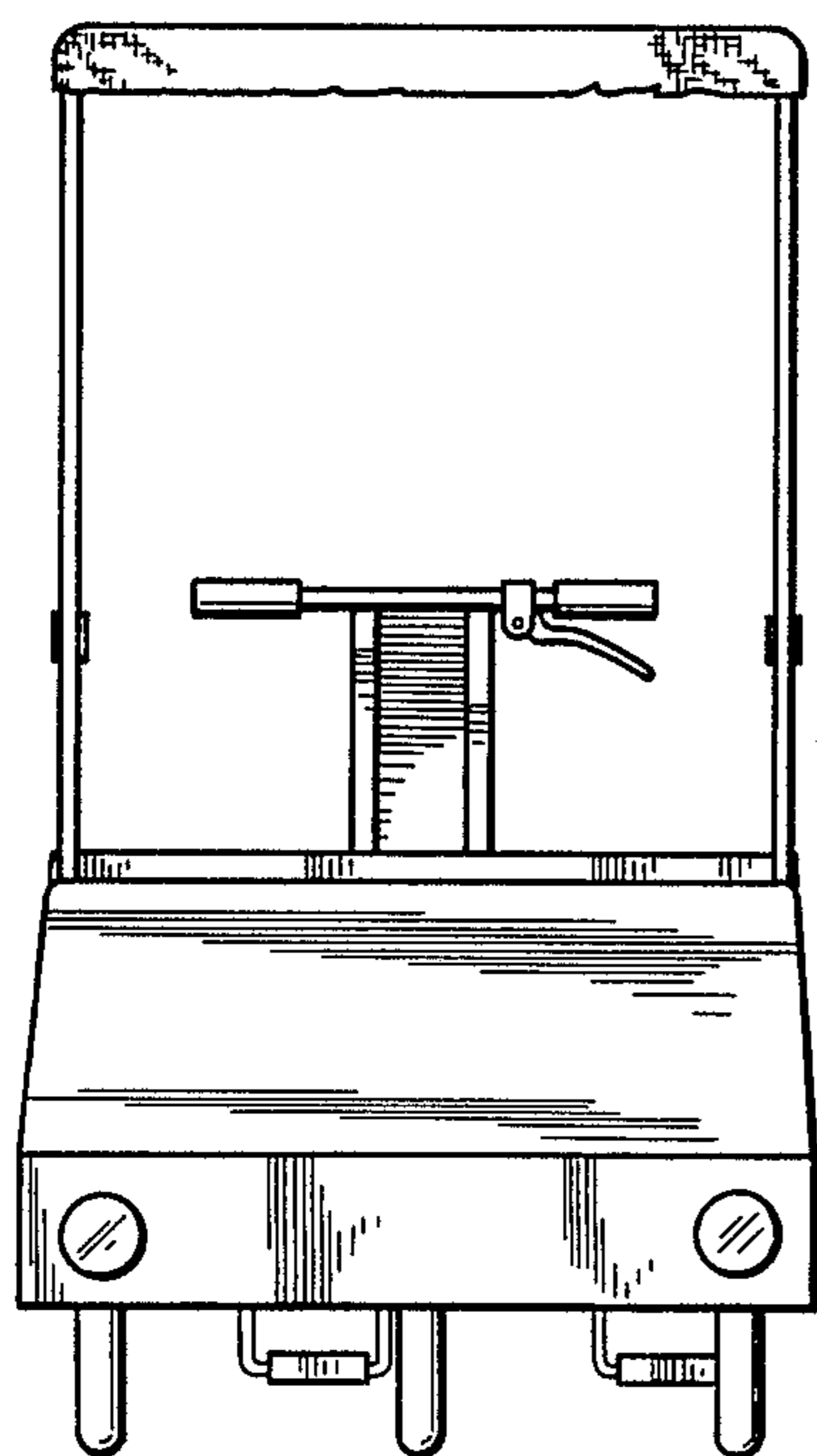

Fig. 9

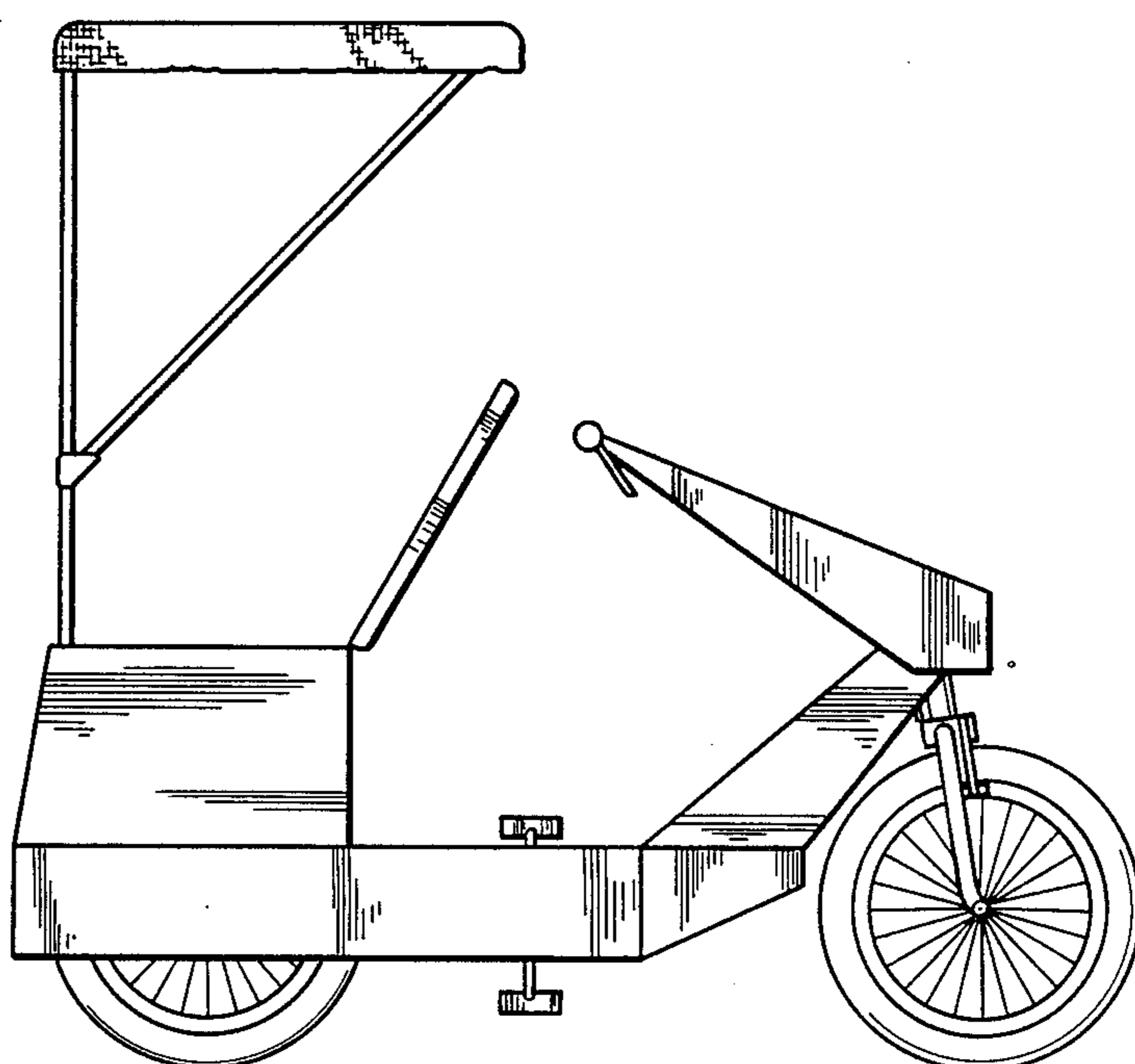

Fig. 10

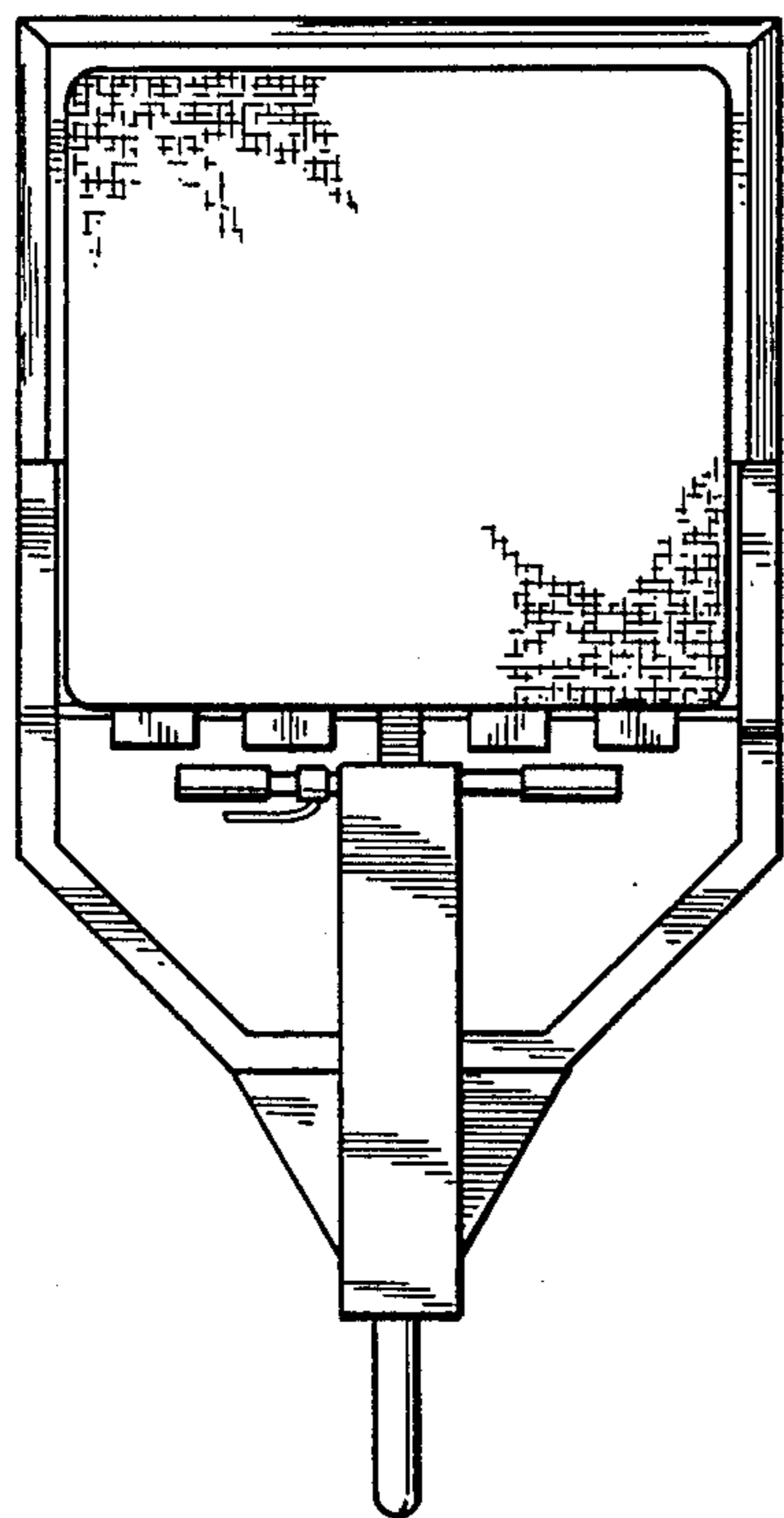

Fig. 11

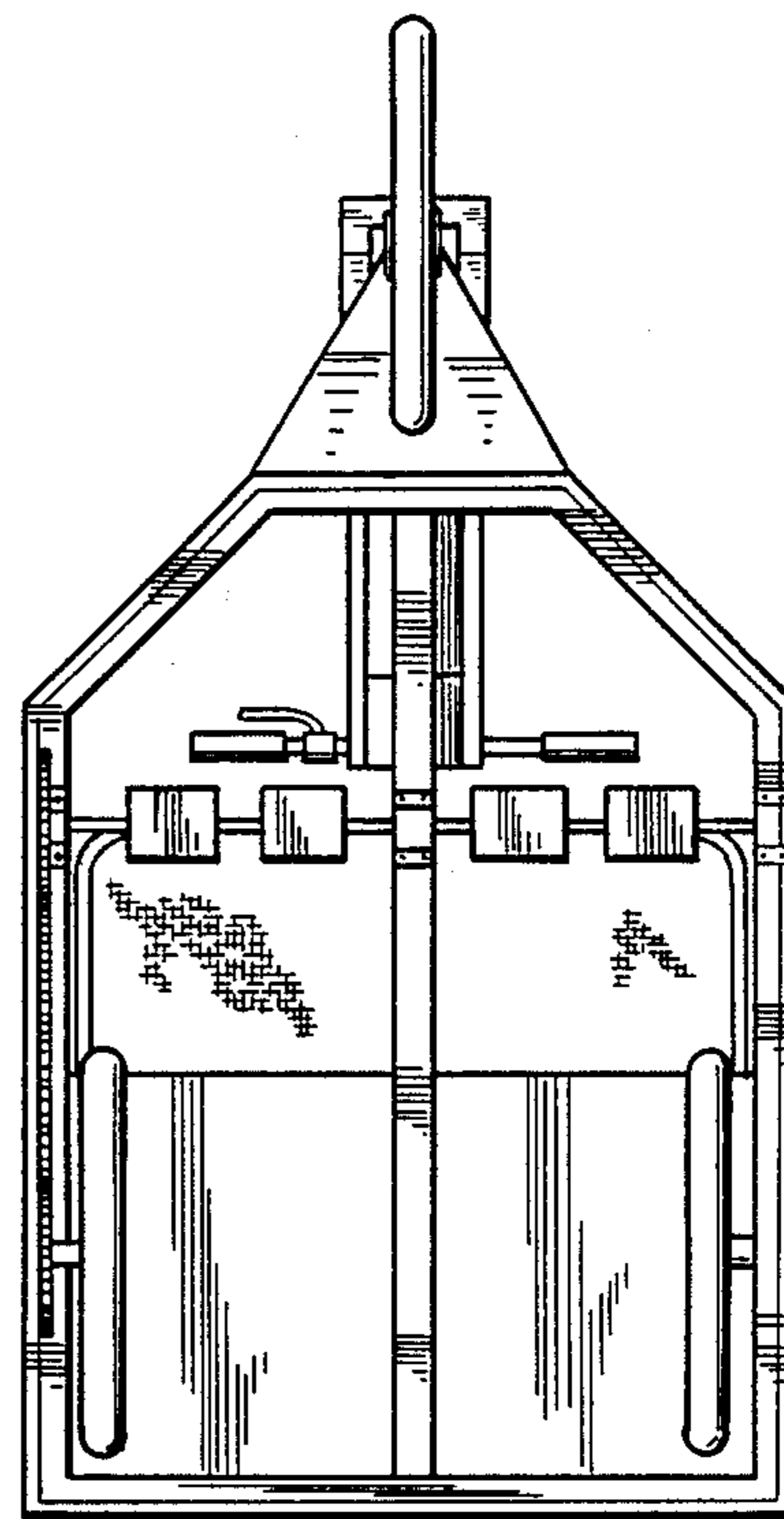

Fig. 12