

[54] BOAT HATCH

[75] Inventors: Allan Brown, North Miami Beach; Robert B. Gowens, Plantation; Valentine Jenkins, Pembroke Lakes, all of Fla.

[73] Assignee: Cigarette Racing Team, Inc., North Miami Beach, Fla.

[\*\*] Term: 14 Years

[21] Appl. No.: 95,513

[22] Filed: Sep. 10, 1987

Related U.S. Application Data

[63] Continuation-in-part of Ser. No. 792,974, Oct. 30, 1985.

[52] U.S. Cl. .... D12/317

[58] Field of Search ..... D12/317, 318, 300; 114/201 R, 364, 343

References Cited

U.S. PATENT DOCUMENTS

- D. 193,697 9/1962 Lo ..... D12/317
- D. 292,511 10/1987 Brown et al. .... D12/317
- 3,834,340 9/1974 Thorpe ..... 114/201 R
- 4,846,089 7/1989 Cedergreen ..... 114/201 R

FOREIGN PATENT DOCUMENTS

- 374216 5/1973 U.S.S.R. .... 114/201 R

Primary Examiner—Wallace R. Burke  
Assistant Examiner—Kay H. Chin  
Attorney, Agent, or Firm—Lieberman Rudolph & Nowak

[57] CLAIM

The ornamental design for a boat hatch, as shown and described.

DESCRIPTION

FIG. 1 is a perspective view of a boat hatch showing our new design;

FIG. 2 is an enlarged top plan view thereof;

FIG. 3 is an enlarged perspective view thereof, showing the hatch in open condition;

FIG. 4 is a top plan view of FIG. 3;

FIG. 5 is a front elevational view of FIG. 3;

FIG. 6 is a side elevational view of FIG. 3;

FIG. 7 is a rear elevational view of FIG. 3;

FIG. 8 is an enlarged perspective view of a second embodiment of the hatch, shown in an open condition, the sole difference from the first embodiment residing in the absence of shock absorbing hinges;

FIG. 9 is an enlarged perspective view of a third embodiment of the hatch, shown in an open condition, the sole difference from the first embodiment residing in the absence of hatch "dogs".

The broken lines shown in FIGS. 1 thru 9 of the drawings are for illustrative purposes only and form no part of the claimed design.

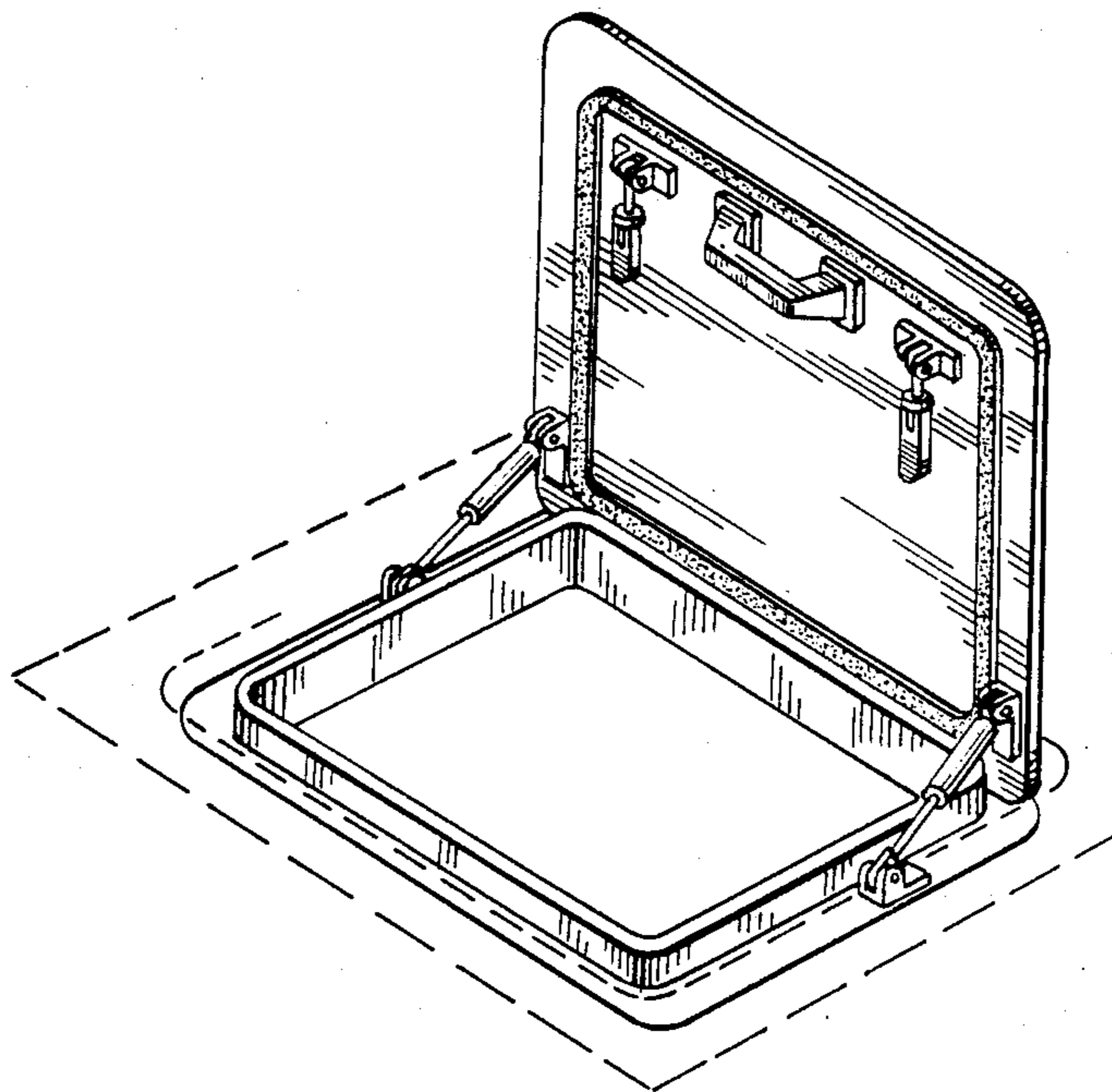

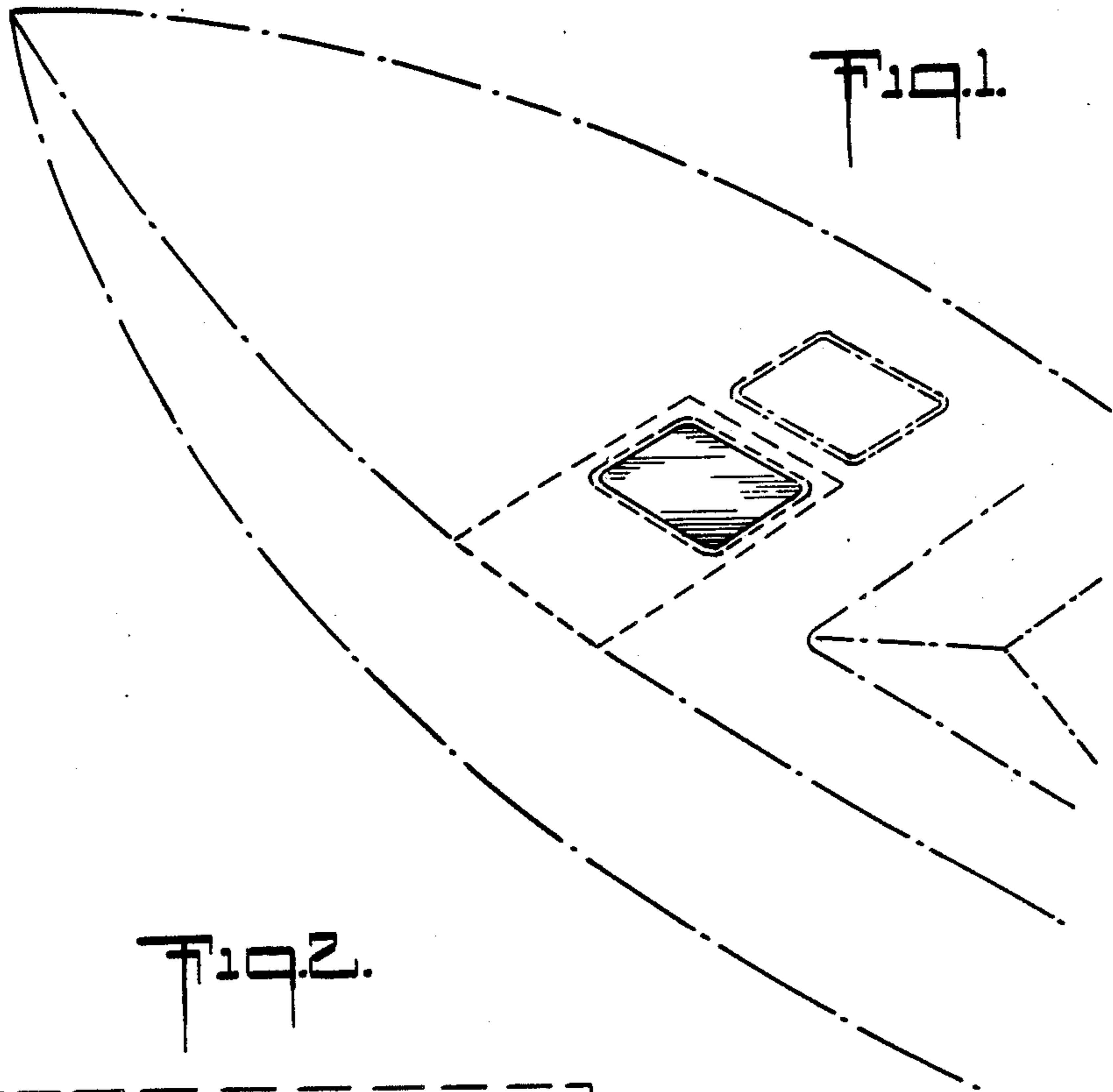

Fig. 2.

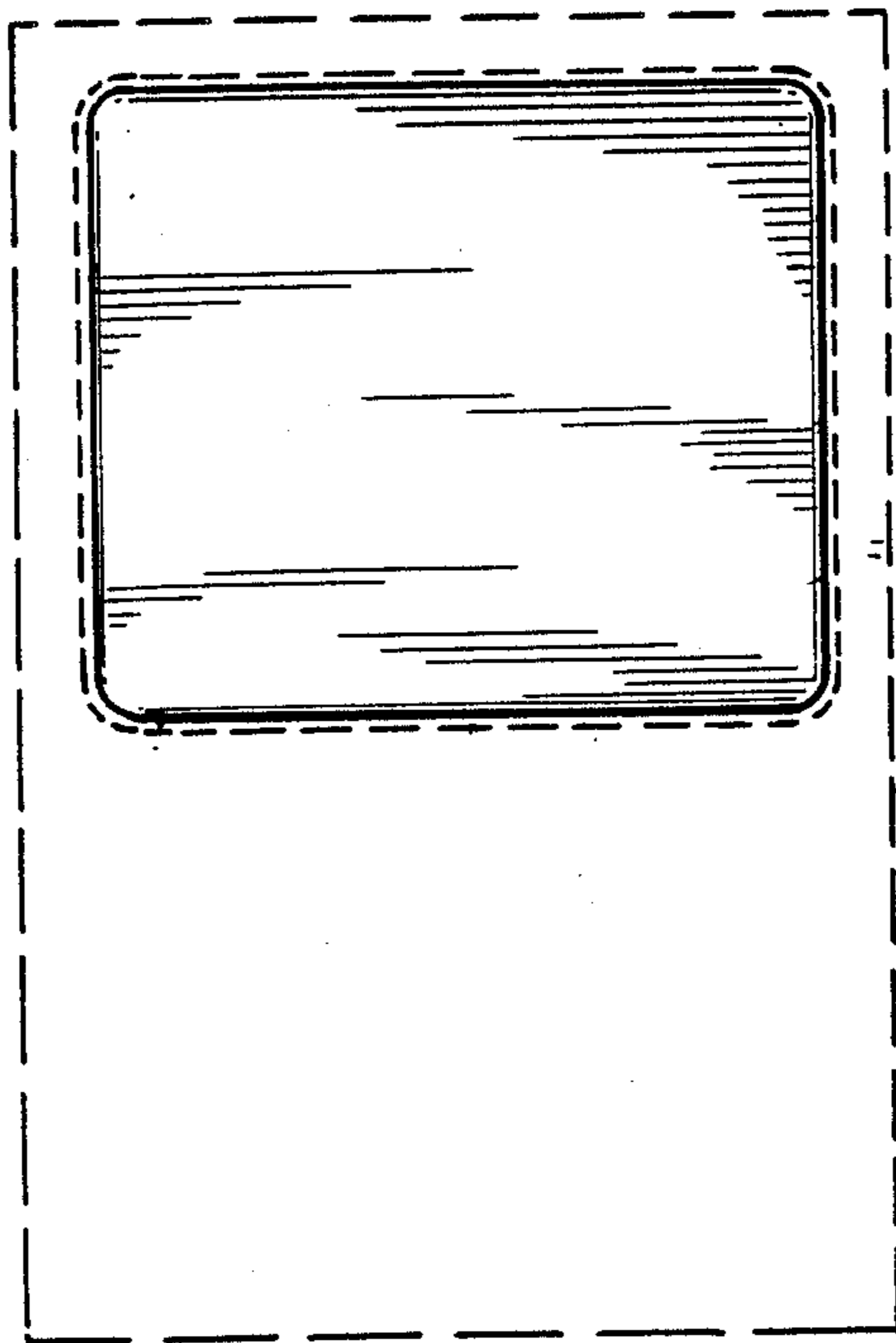

Fig. 4.

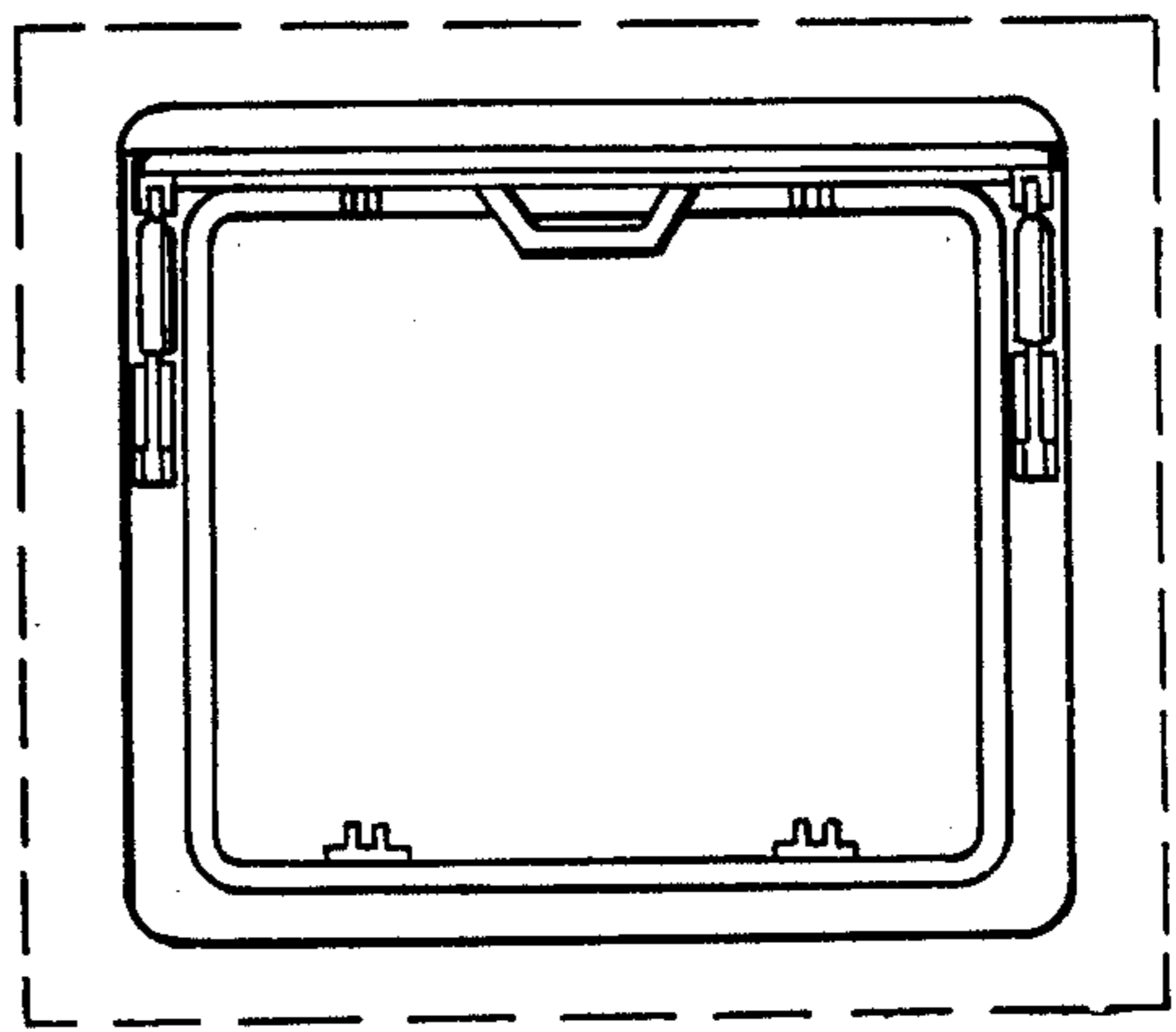

Fig. 3.

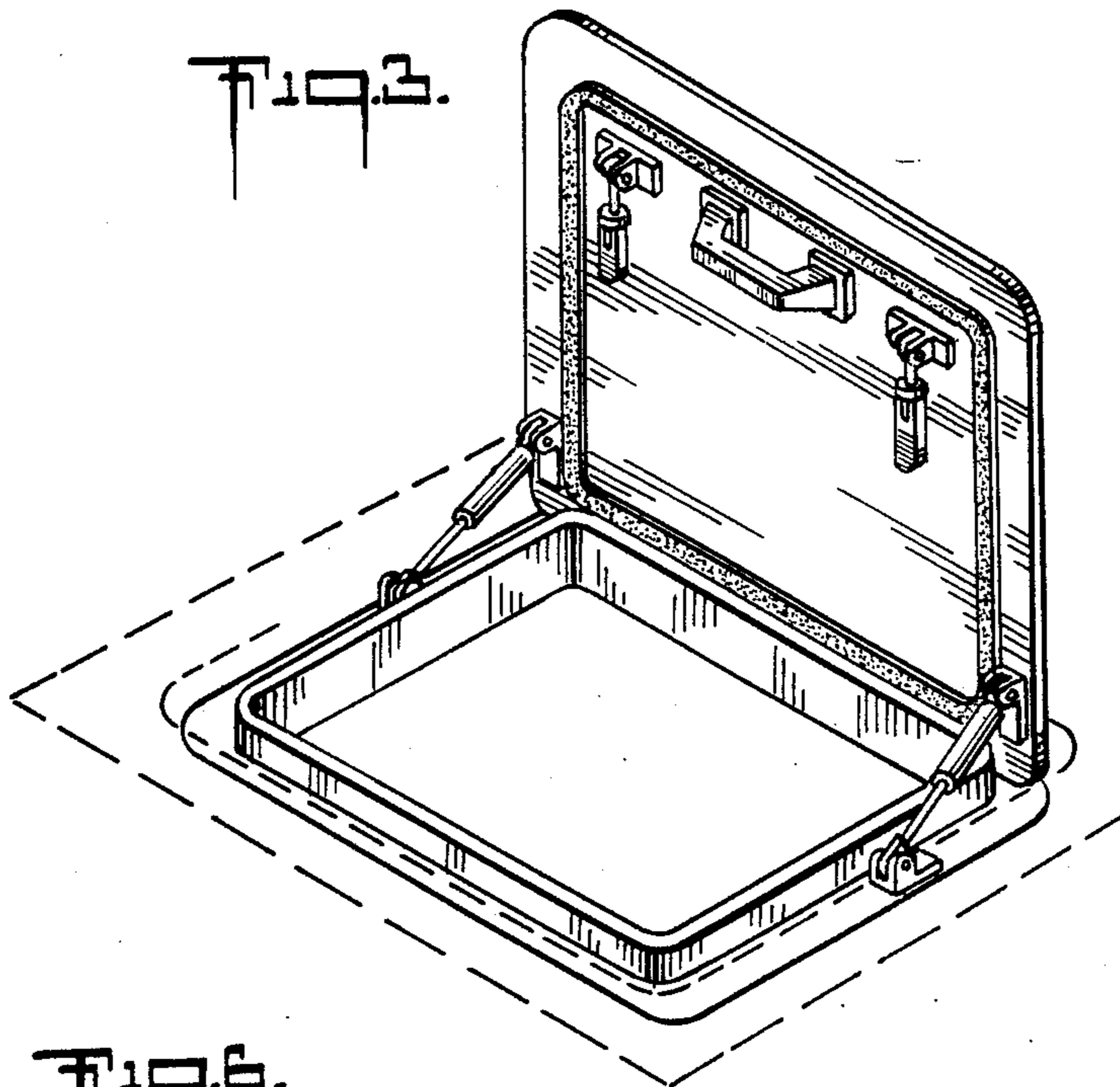

Fig. 6.

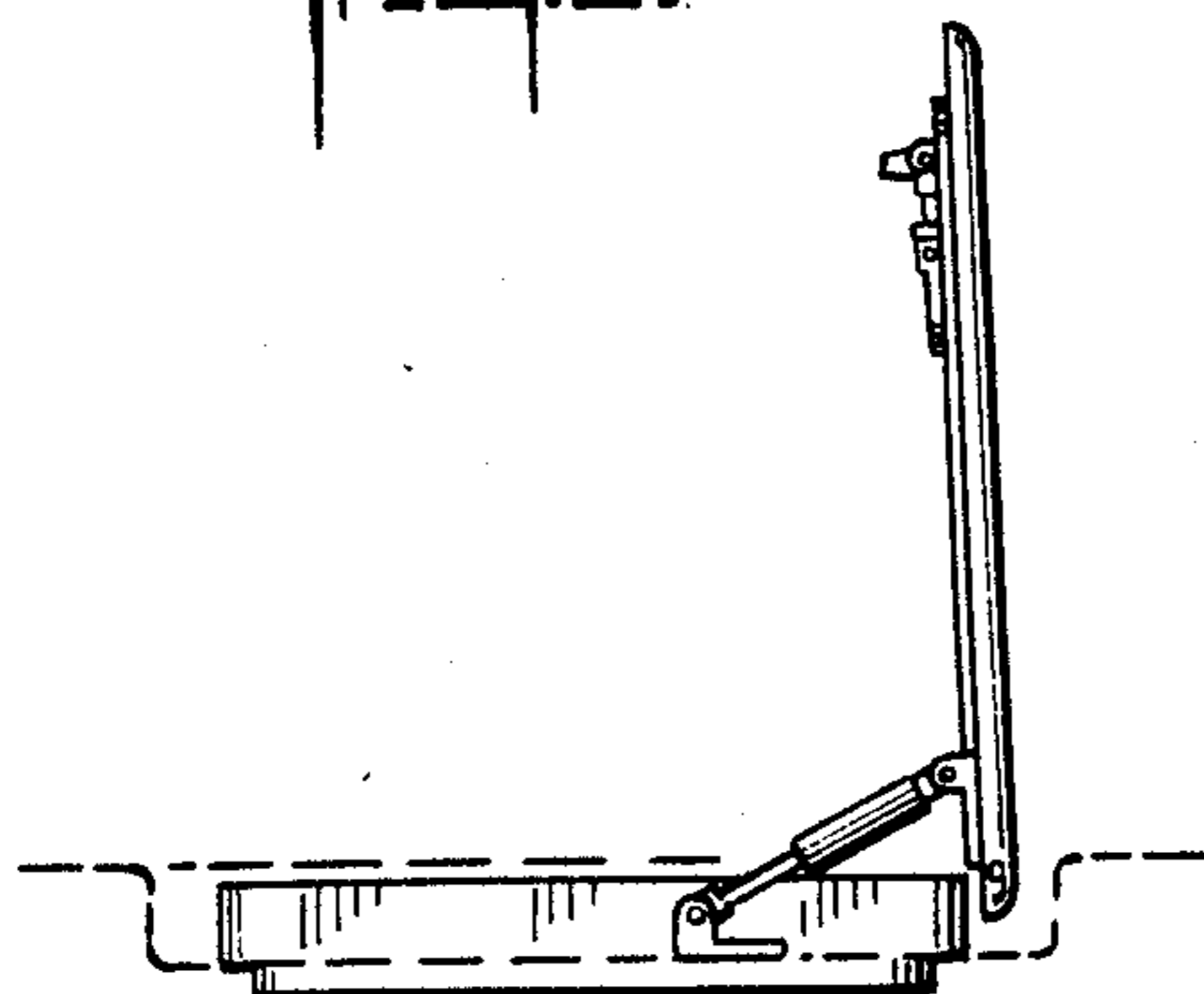

Fig. 5.

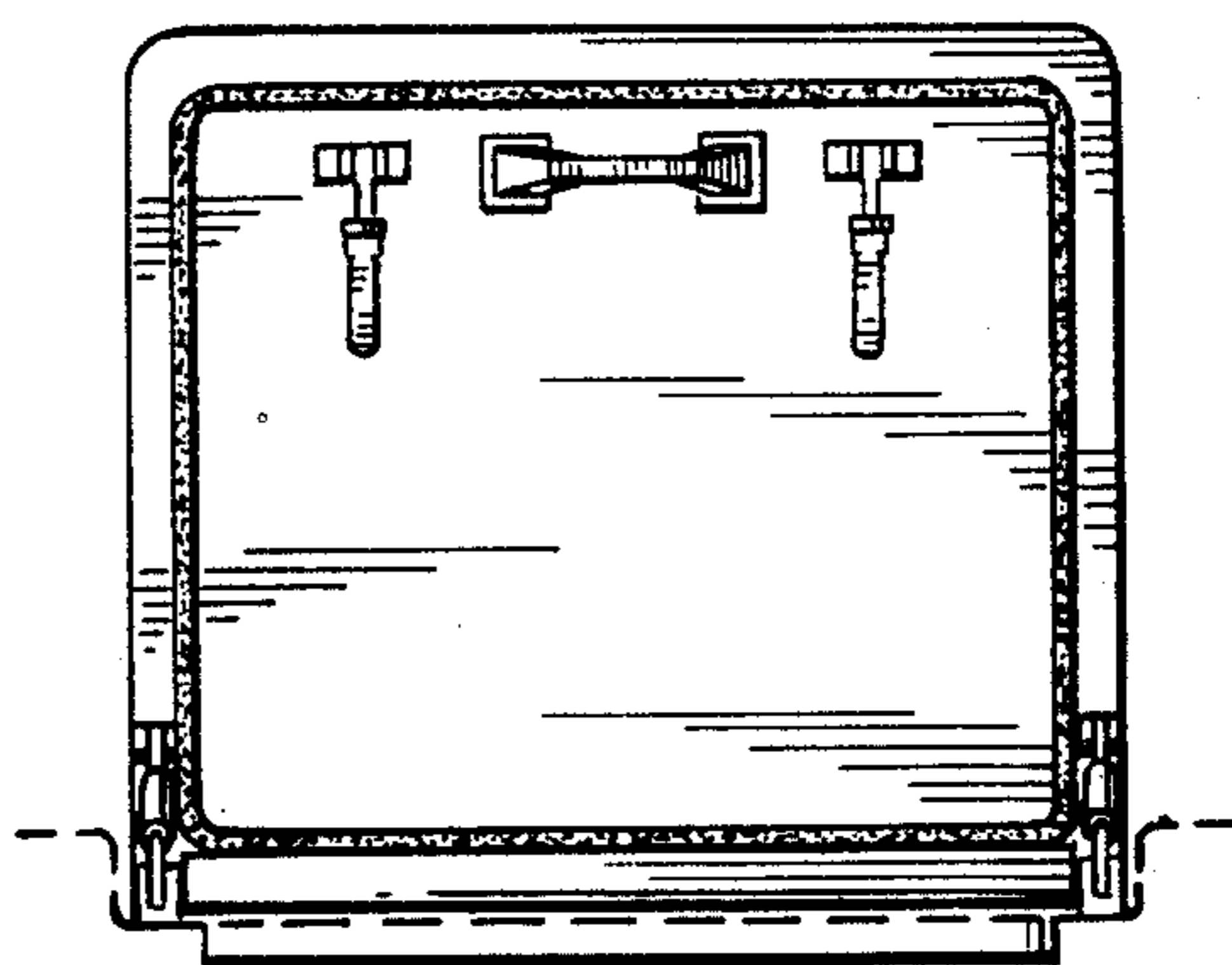

Fig. 7.

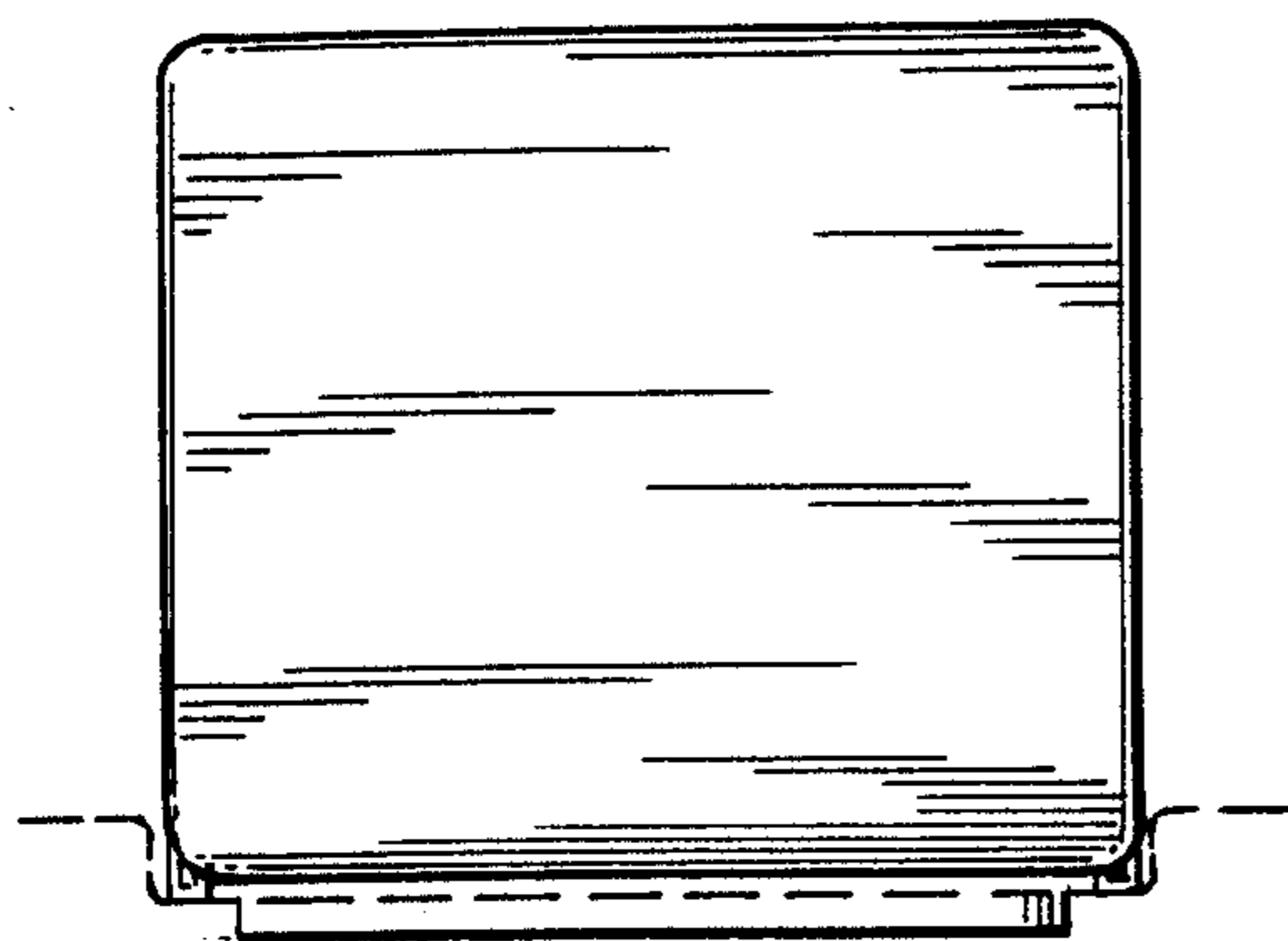

Fig. 8.

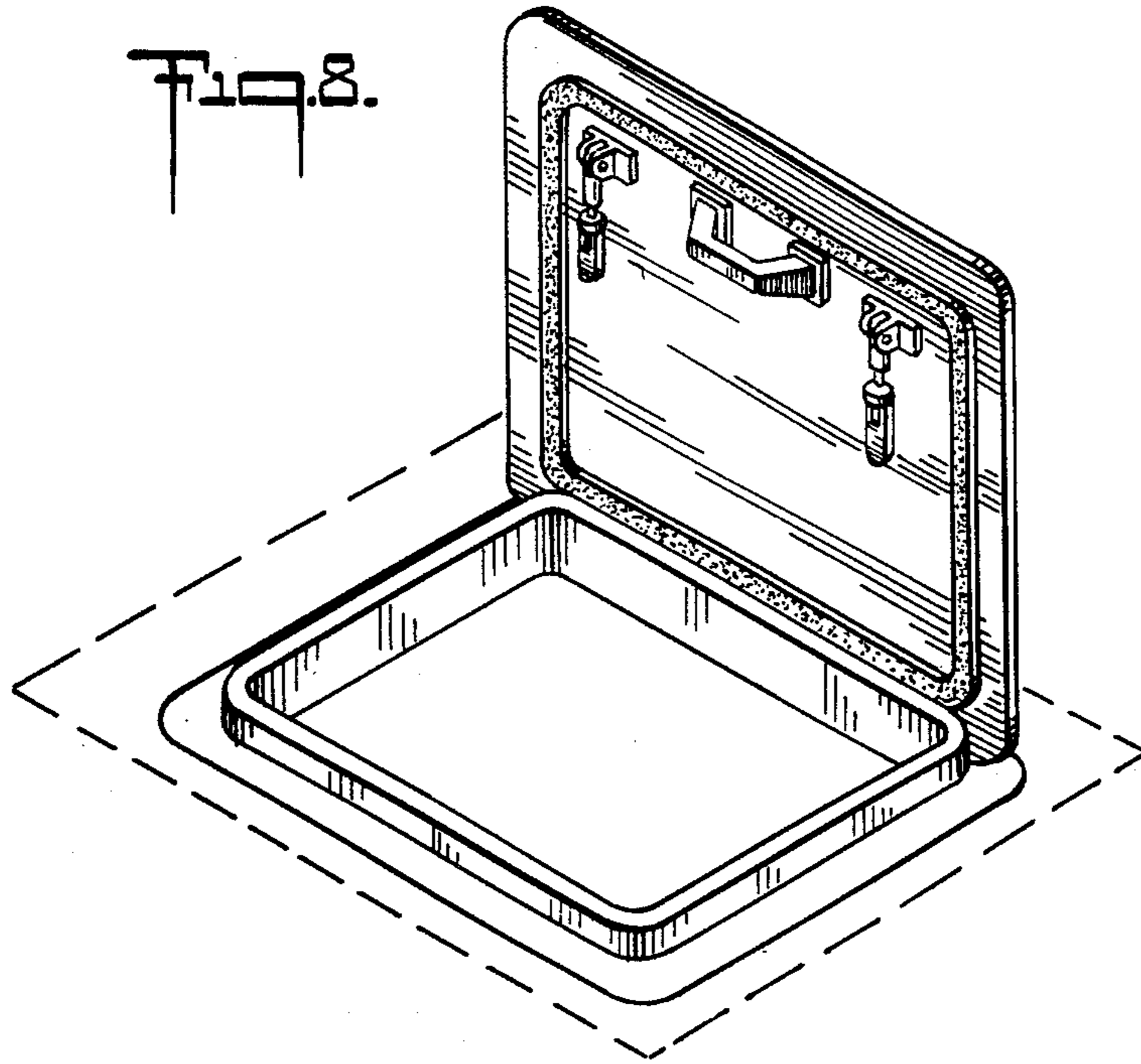

Fig. 9.

