

[54] TOP FOR MERCHANDISE DISPLAY UNIT

DESCRIPTION

[75] Inventors: Dale Hodgson, Parma; John Stram, Stronsville, both of Ohio

[73] Assignee: American Greetings Corporation, Cleveland, Ohio

[\*\*] Term: 14 Years

[21] Appl. No.: 25,015

[22] Filed: Mar. 12, 1987

[52] U.S. Cl. .... D6/491

[58] Field of Search ..... D6/491, 492, 494, 511, D6/396, 509; D8/358

[56] References Cited

U.S. PATENT DOCUMENTS

- D. 202,366 9/1965 Bishop ..... D8/358
- D. 231,898 6/1974 Saxon ..... D8/358
- D. 240,192 6/1976 Balmer, Jr. .... D8/358 X
- D. 265,024 6/1982 Johnson et al. .... D6/24
- D. 271,077 10/1983 Houghton ..... D8/358
- 2,327,742 8/1943 Rosenberg .
- 4,461,520 7/1984 Alneng ..... D6/510 X
- 4,482,062 11/1984 Huntsberry .

FOREIGN PATENT DOCUMENTS

- 57678 12/1986 Canada .
- 1031946 11/1986 United Kingdom .

OTHER PUBLICATIONS

Devoke Data Products Catalog, pp. 26-27, bottom of pages, Design 4b, C-44 Box.

Primary Examiner—Bruce W. Dunkins  
Assistant Examiner—Janice Seeger  
Attorney, Agent, or Firm—Baldwin, Egan & Fetzer

[57] CLAIM

The ornamental design for top for merchandise display unit, as shown and described.

FIG. 1 is a top view of a top for merchandise display unit, embodying our new design;  
 FIG. 2 is an end elevational view taken from the left hand end of the top shown in FIG. 1;  
 FIG. 3 is an end elevational view taken from the right hand end of the top of FIG. 1;  
 FIG. 4 is a front elevational view of the top of FIG. 1;  
 FIG. 5 is a bottom plan view of the top of FIG. 1;  
 FIG. 6 is an end elevational view taken from the left hand end of FIG. 5;  
 FIG. 7 is an end elevational view taken from the right hand end of FIG. 5;  
 FIG. 8 is a rear elevational view of the top of FIG. 1;  
 FIG. 9 is a top plan view of a modified top for a merchandise display unit, and embodying the invention;  
 FIG. 10 is a rear elevational view thereof;  
 FIG. 11 is a rear elevational view thereof;  
 FIG. 12 is an end elevational view taken from the right hand end of FIG. 9;  
 FIG. 12a is an end elevational view taken from the left hand end of FIG. 9;  
 FIG. 13 is an enlarged perspective view taken from the upper portion of FIG. 9;  
 FIG. 14 is a generally perspective enlarged view taken from the front of FIG. 9;  
 FIG. 15 is an enlarged top plan view of a further modification of top for a merchandise display unit, embodying the invention;  
 FIG. 16 is a front elevational view of the top shown in FIG. 15;  
 FIG. 16a is a rear elevational view of the top of FIG. 15;  
 FIG. 17 is a bottom plan view of the top of FIG. 15;  
 FIG. 18 is a sectional view taken generally along the plane of line 18—18 of FIG. 1;  
 FIG. 19 is a sectional view taken generally along the plane of line 19—19 of FIG. 9; and  
 FIG. 20 is a sectional view taken generally along the plane of line 20—20 of FIG. 15.  
 The tops are adapted for mounting on column structure of a merchandise display unit, such as for instance a "spinner type" merchandise display unit.

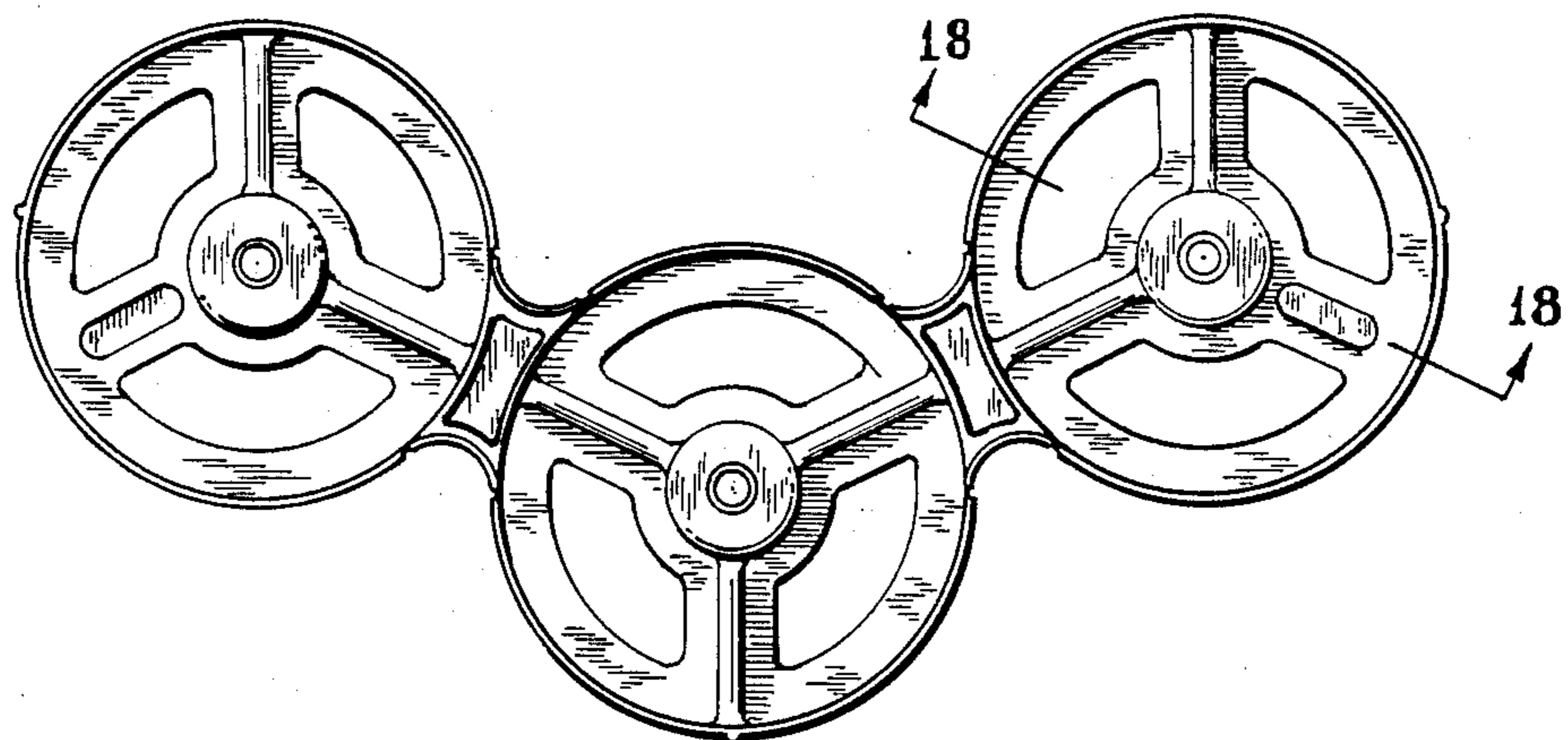

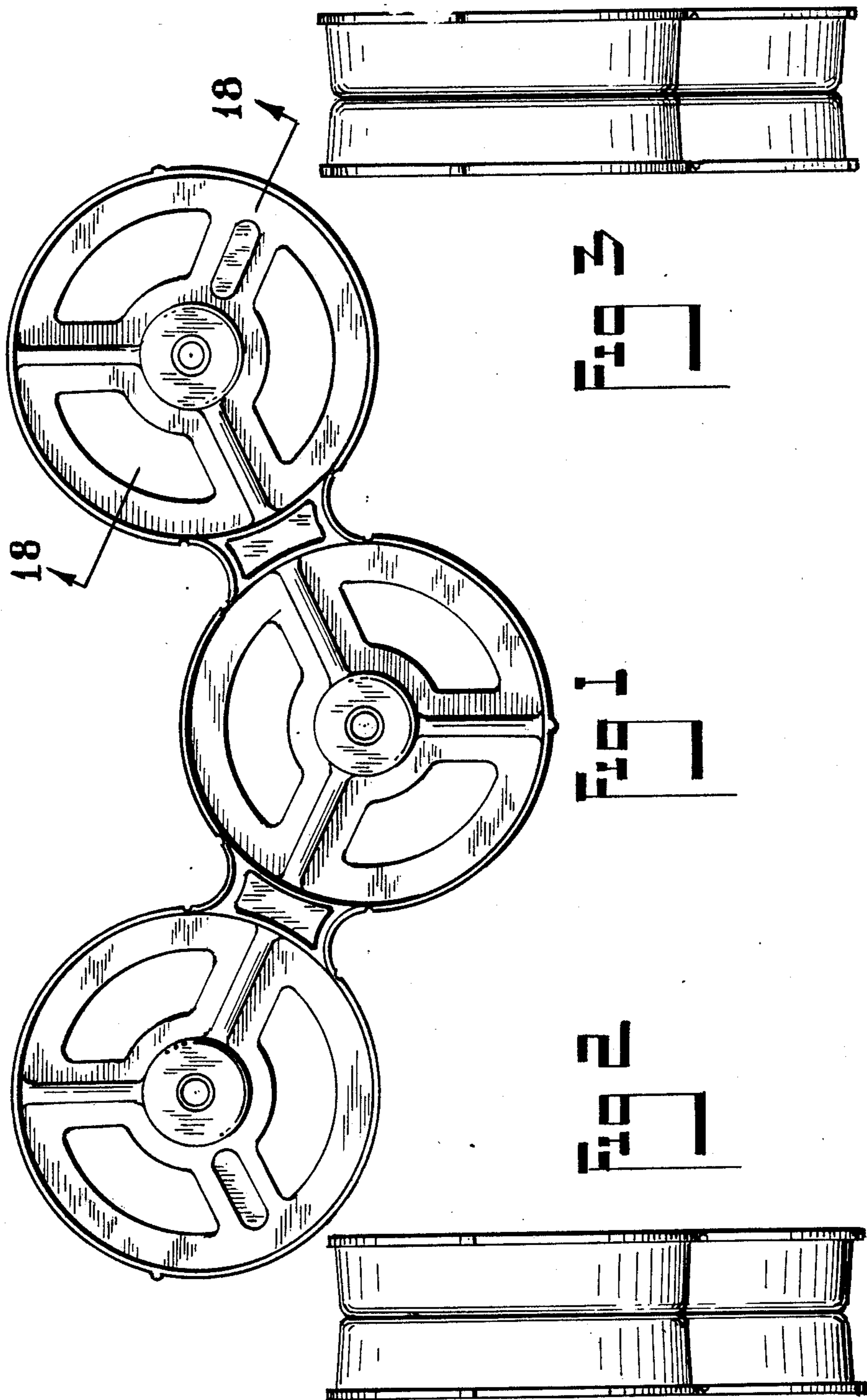

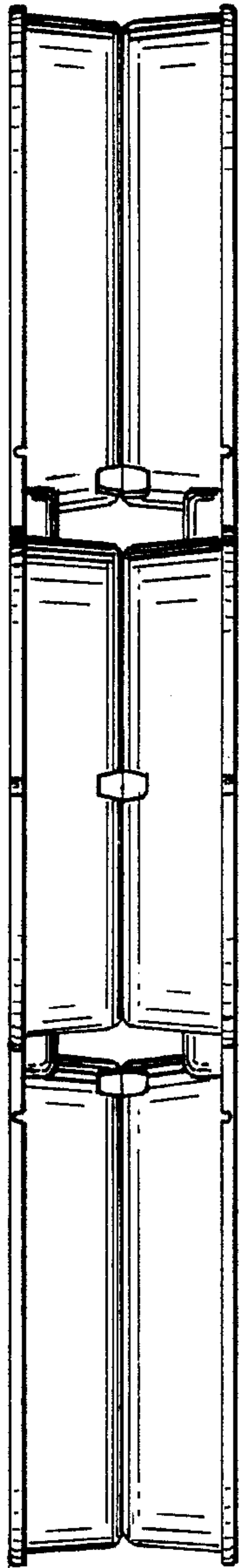

FIG 4

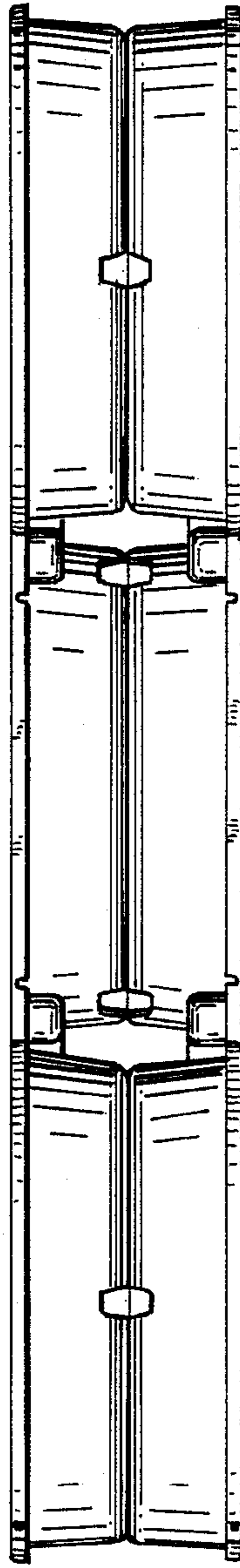
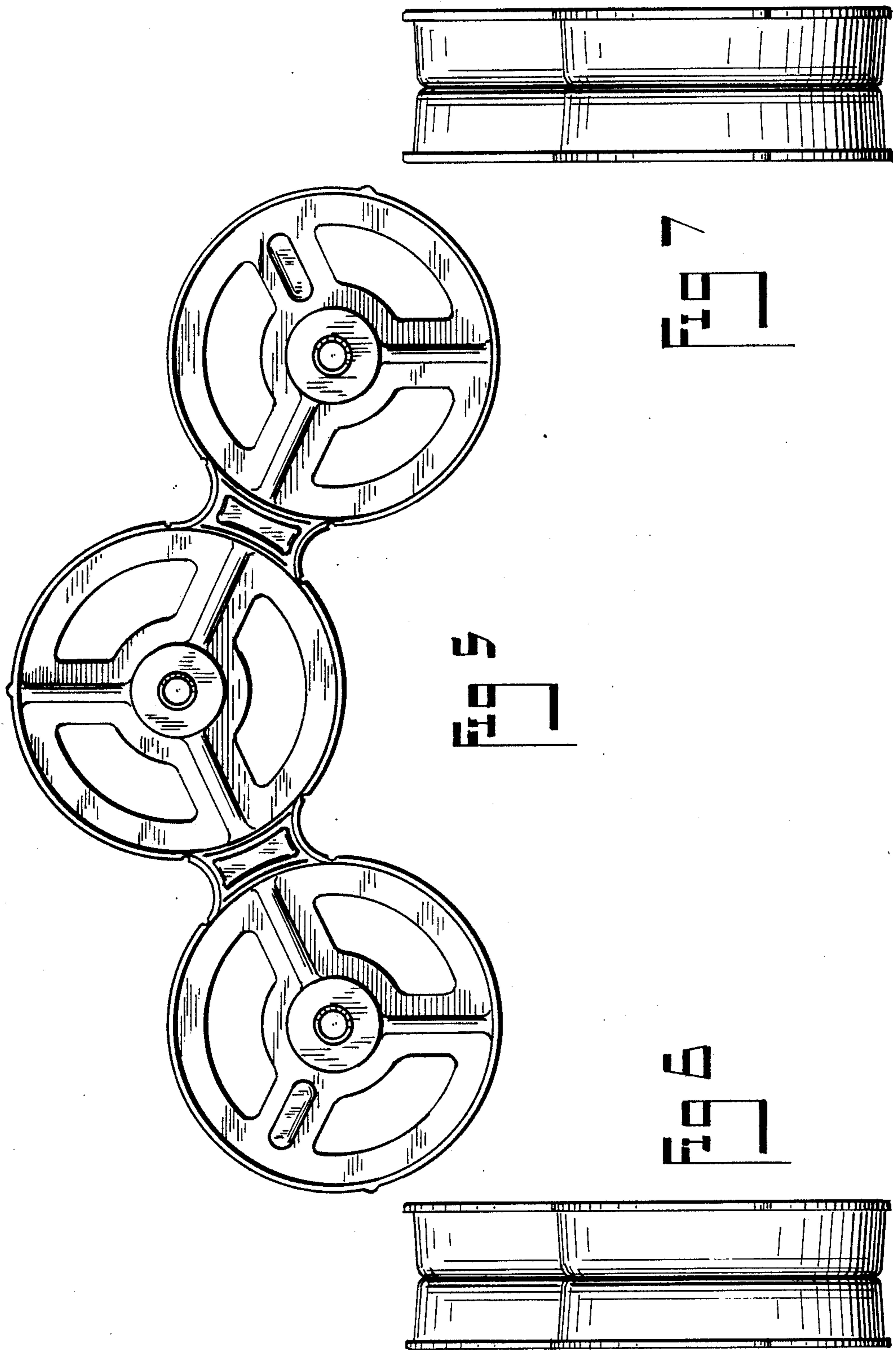

FIG 5



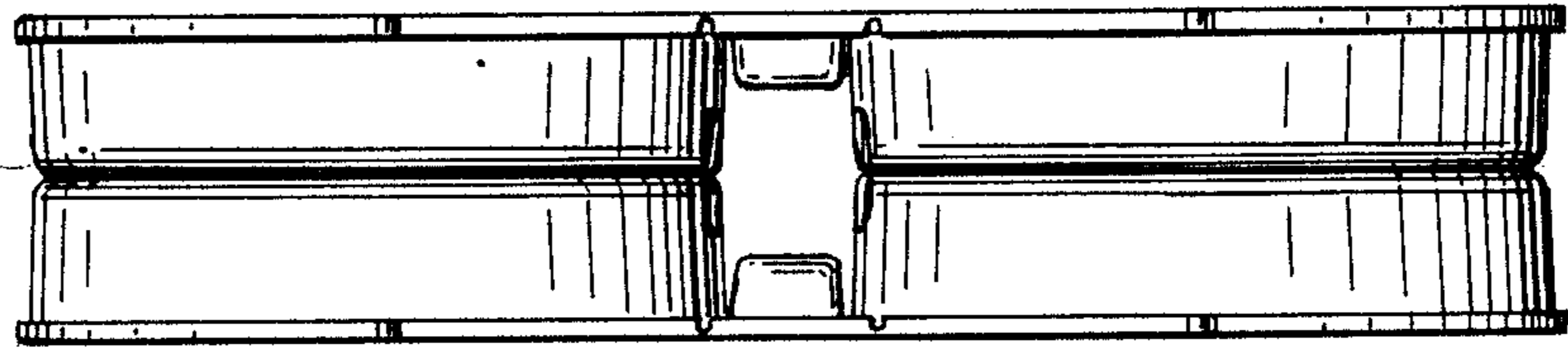

Fig. 10

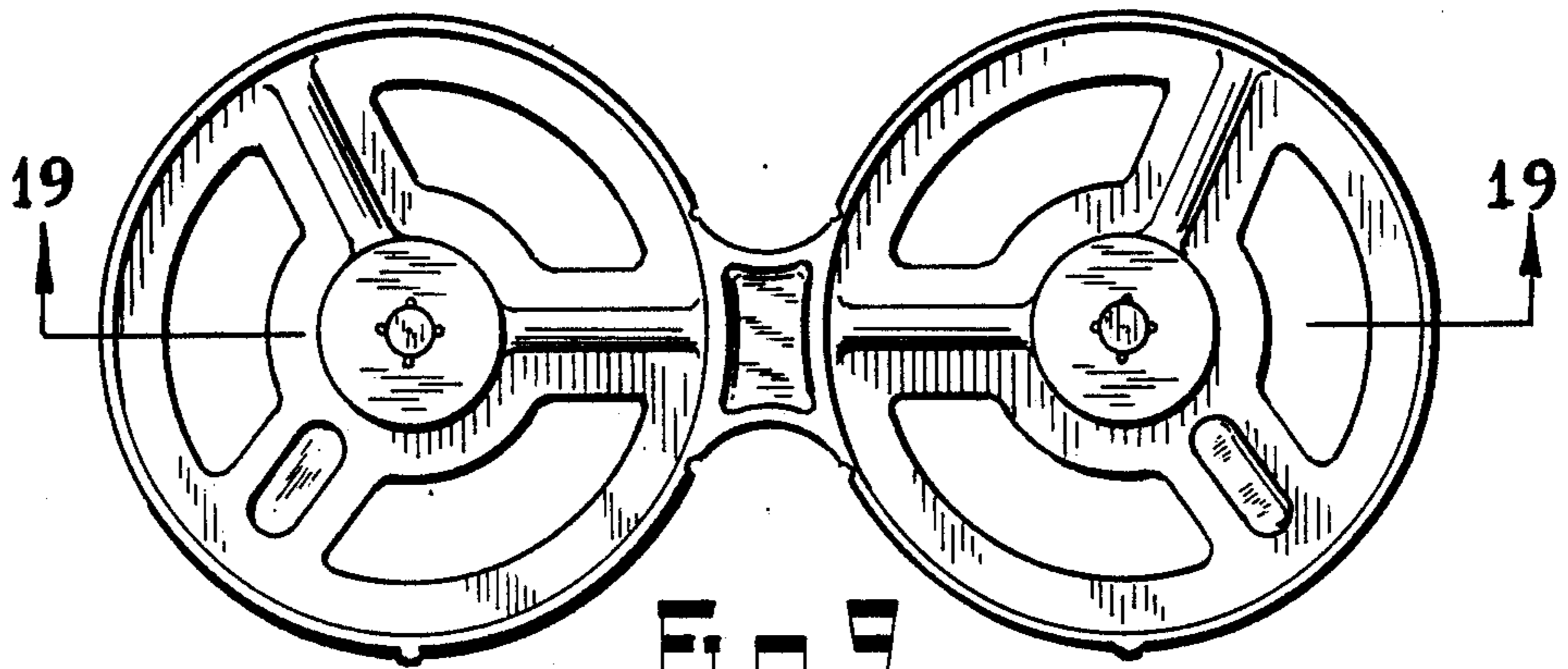

Fig. 11

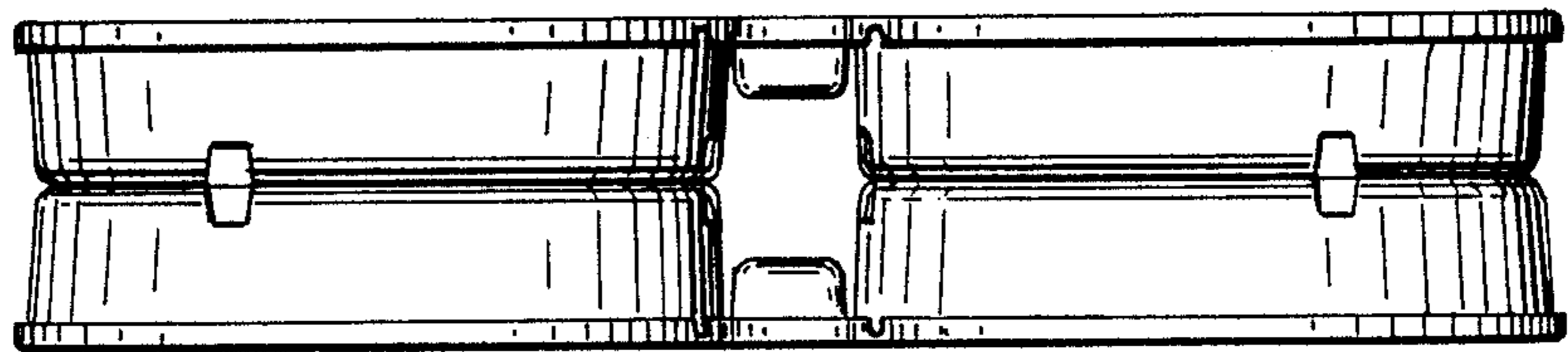

Fig. 12

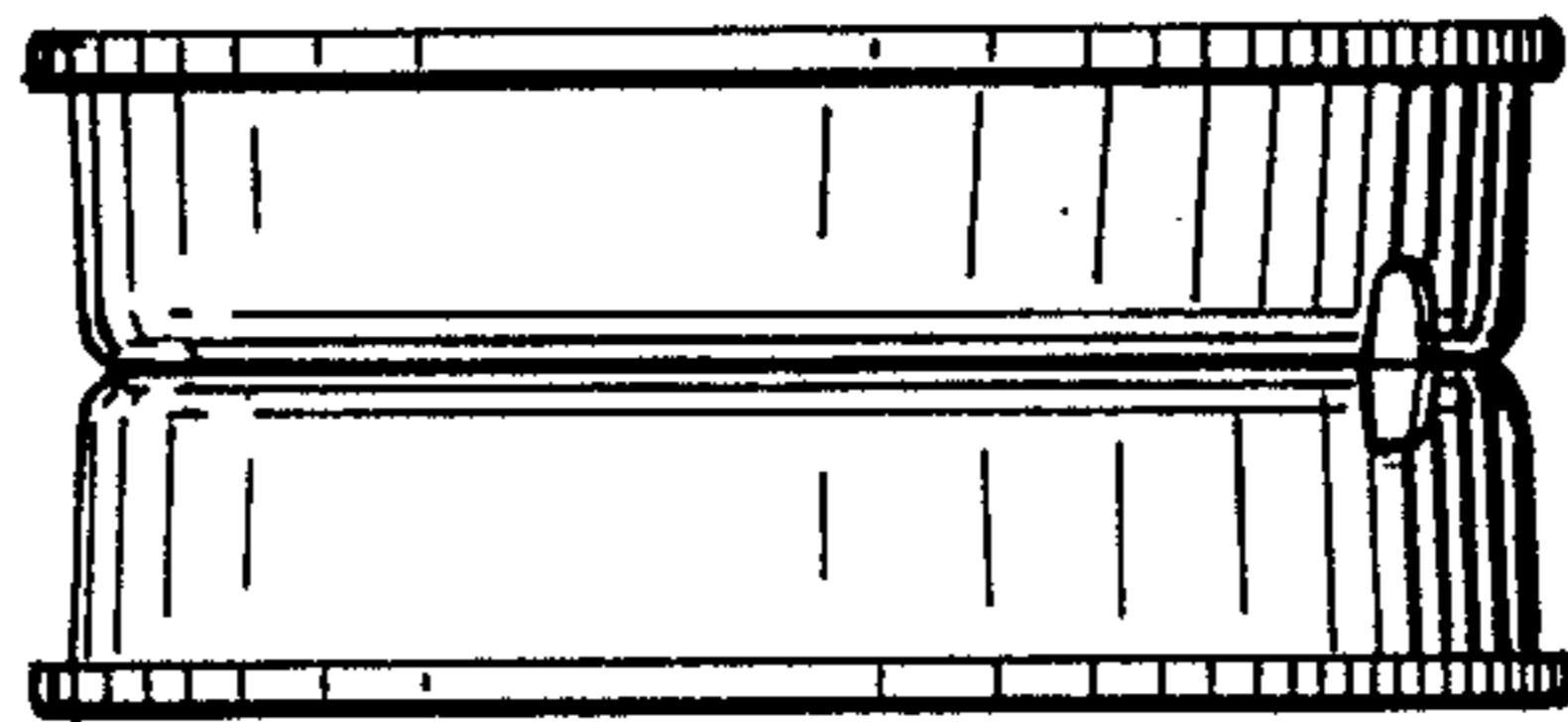

Fig. 13

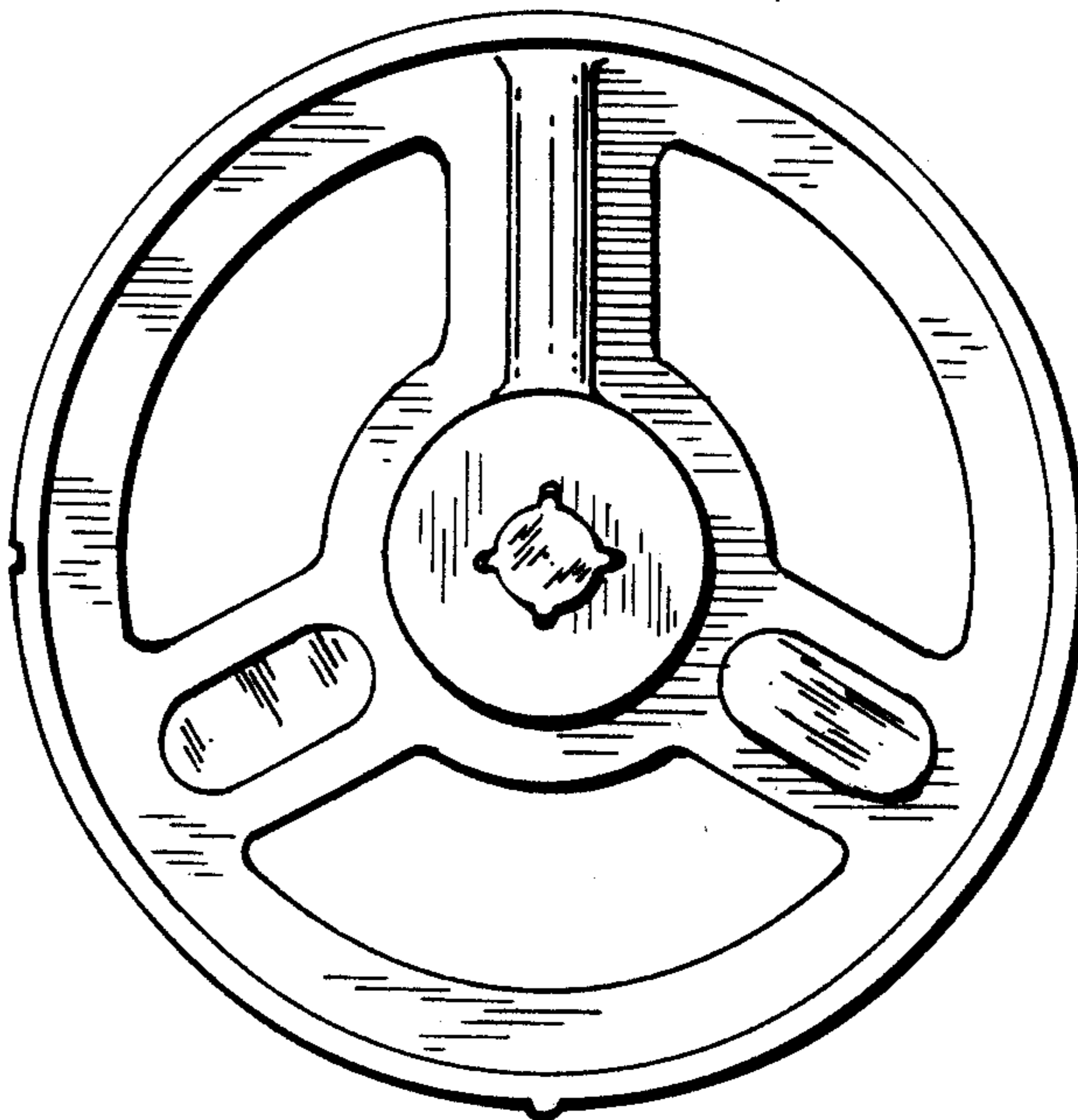

Fig 17

Fig 1Aa

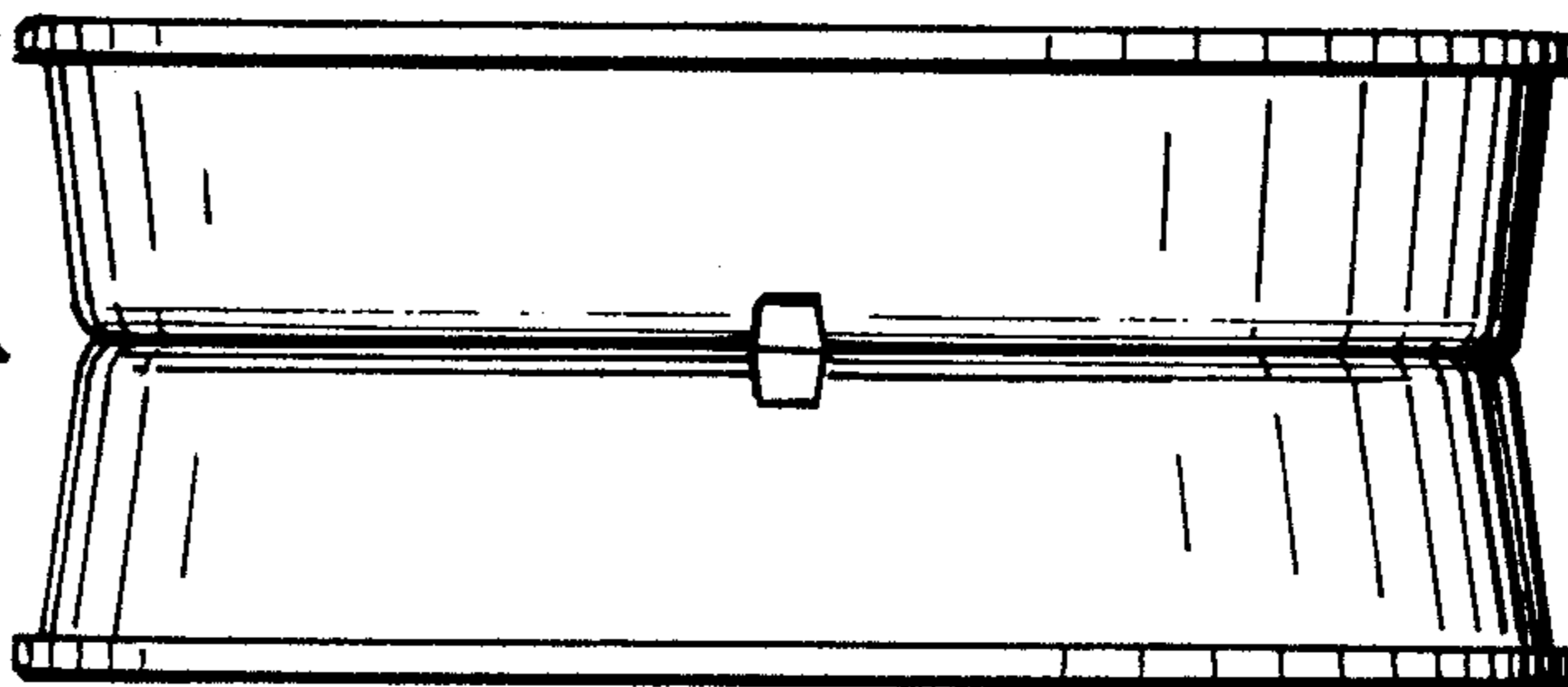

Fig 1Ba

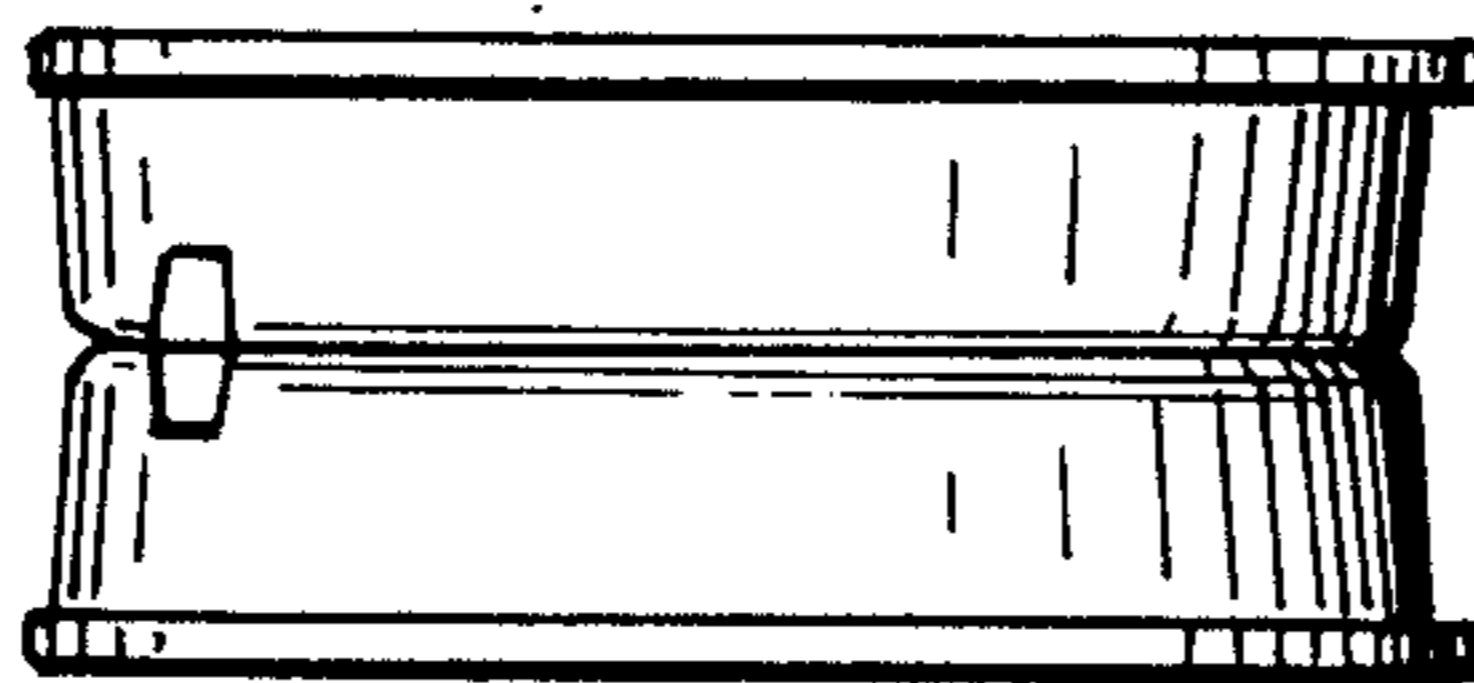

FIG. 2

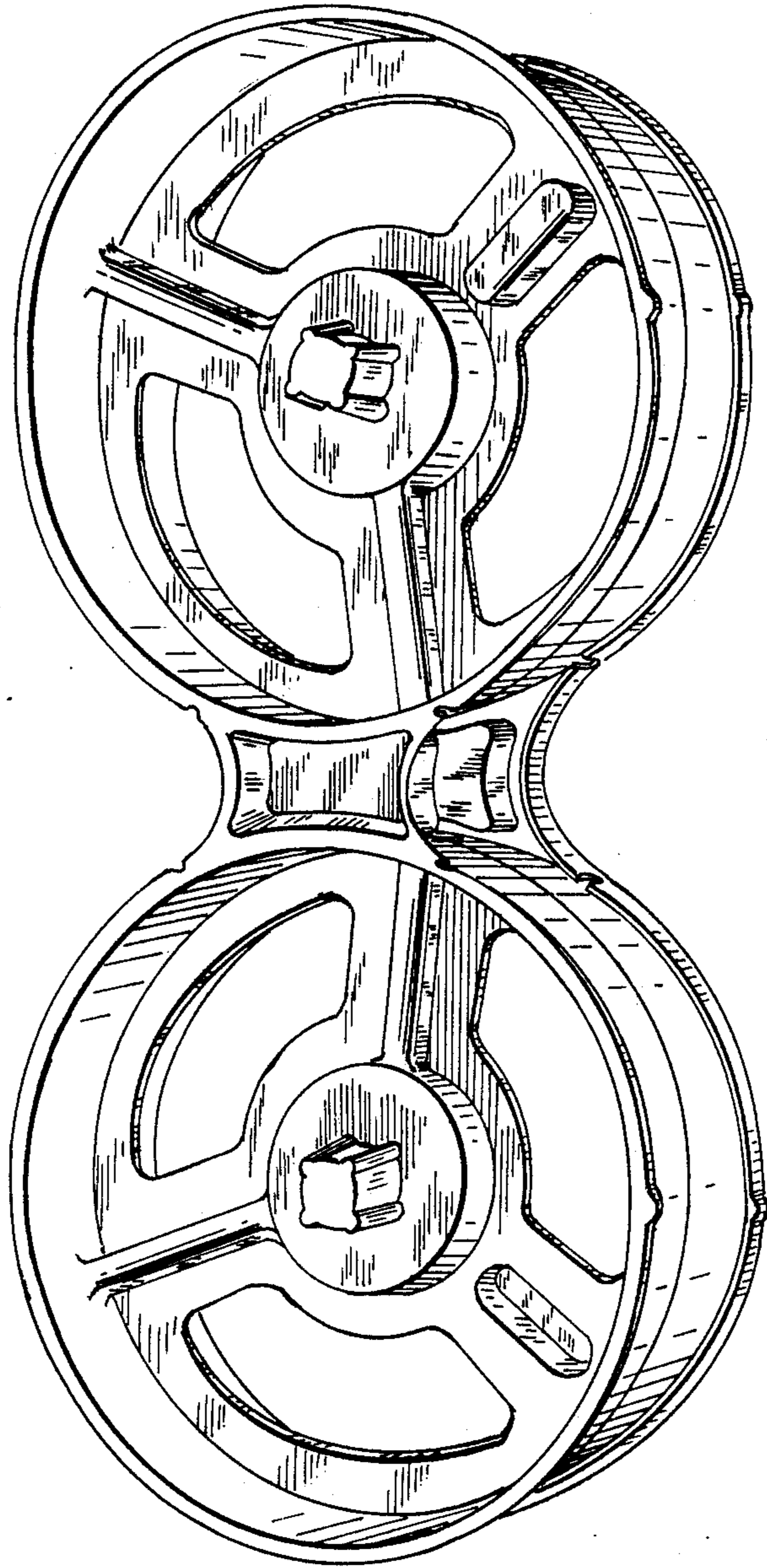
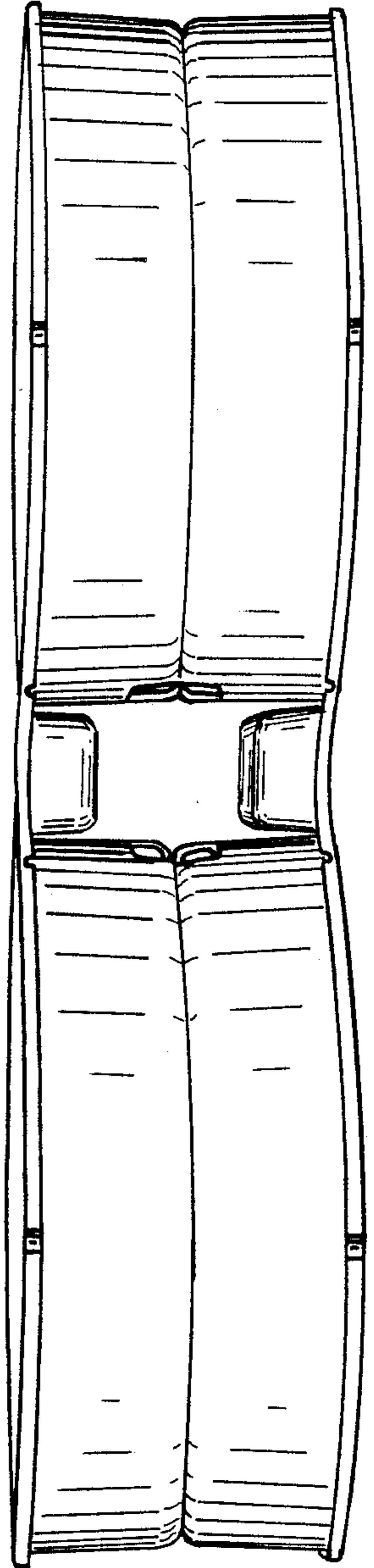

FIG. 3



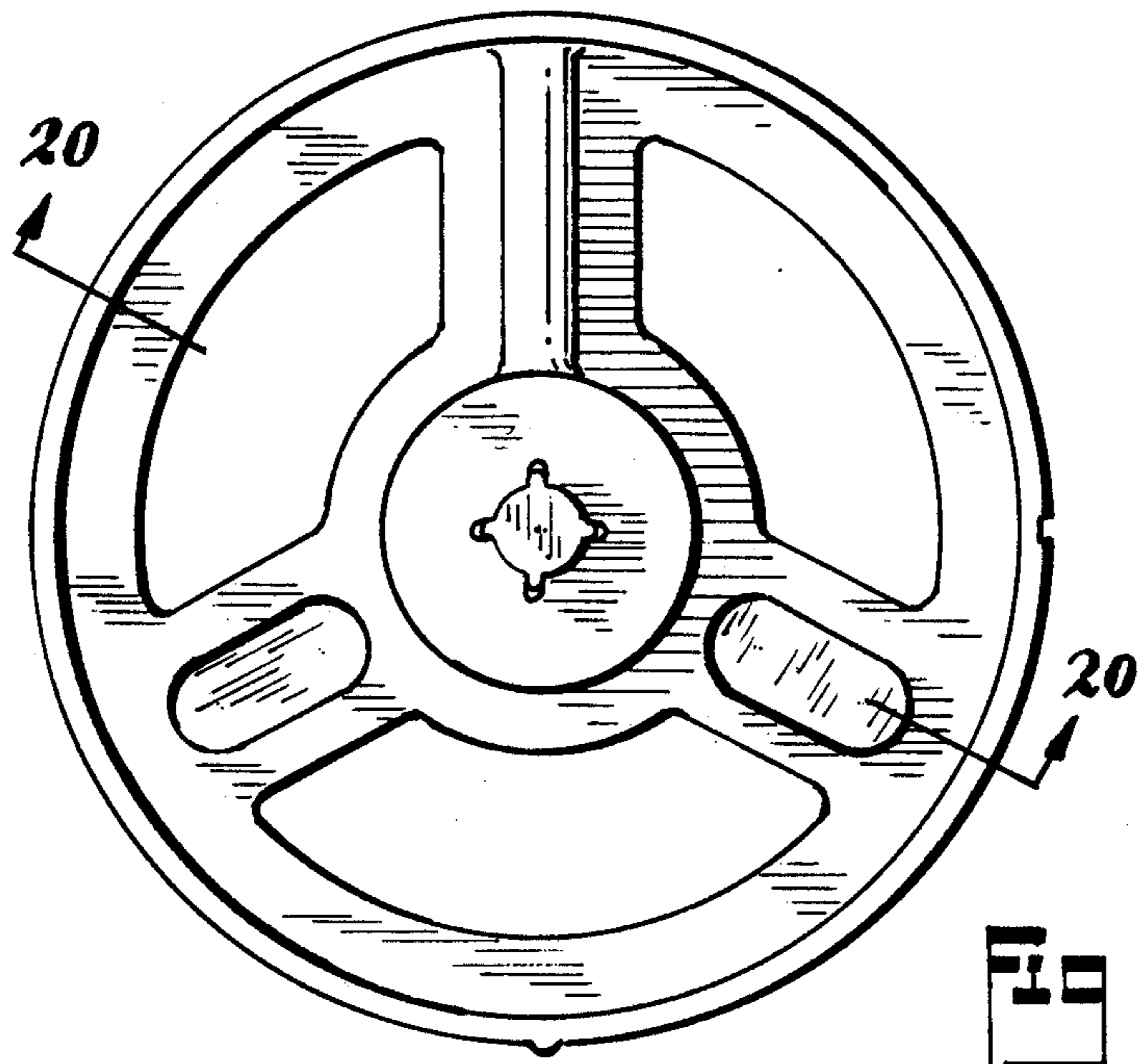

FIG 15

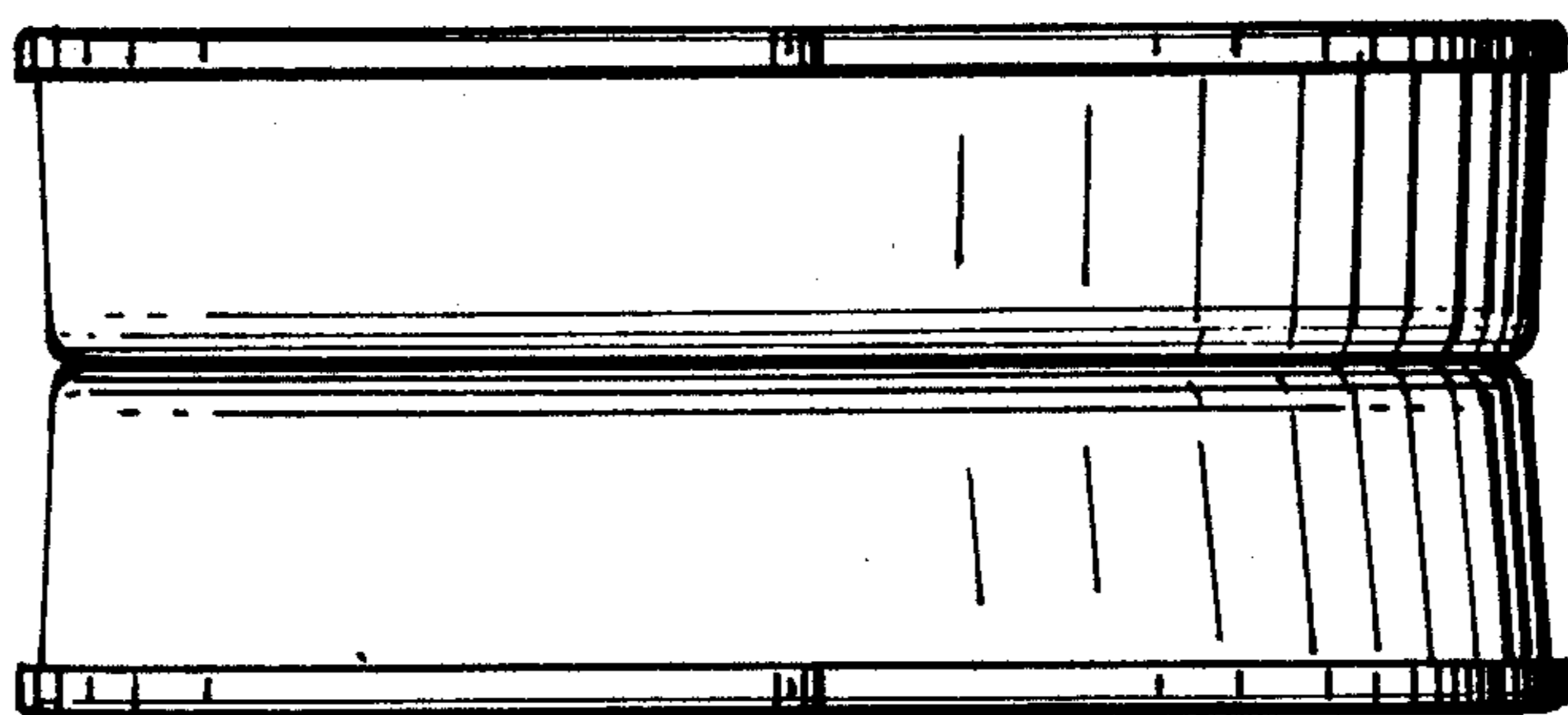

FIG 1A



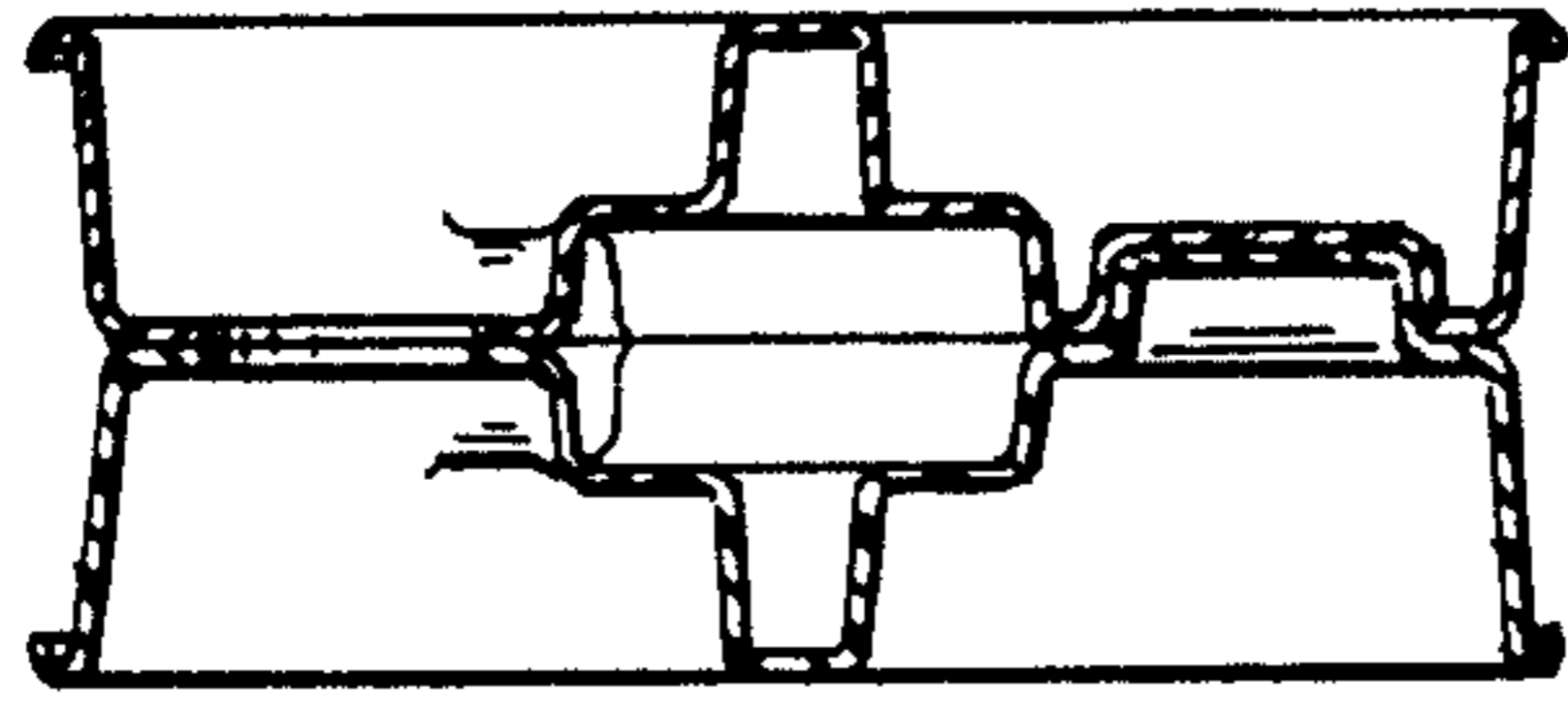

Fig 18

Fig 19

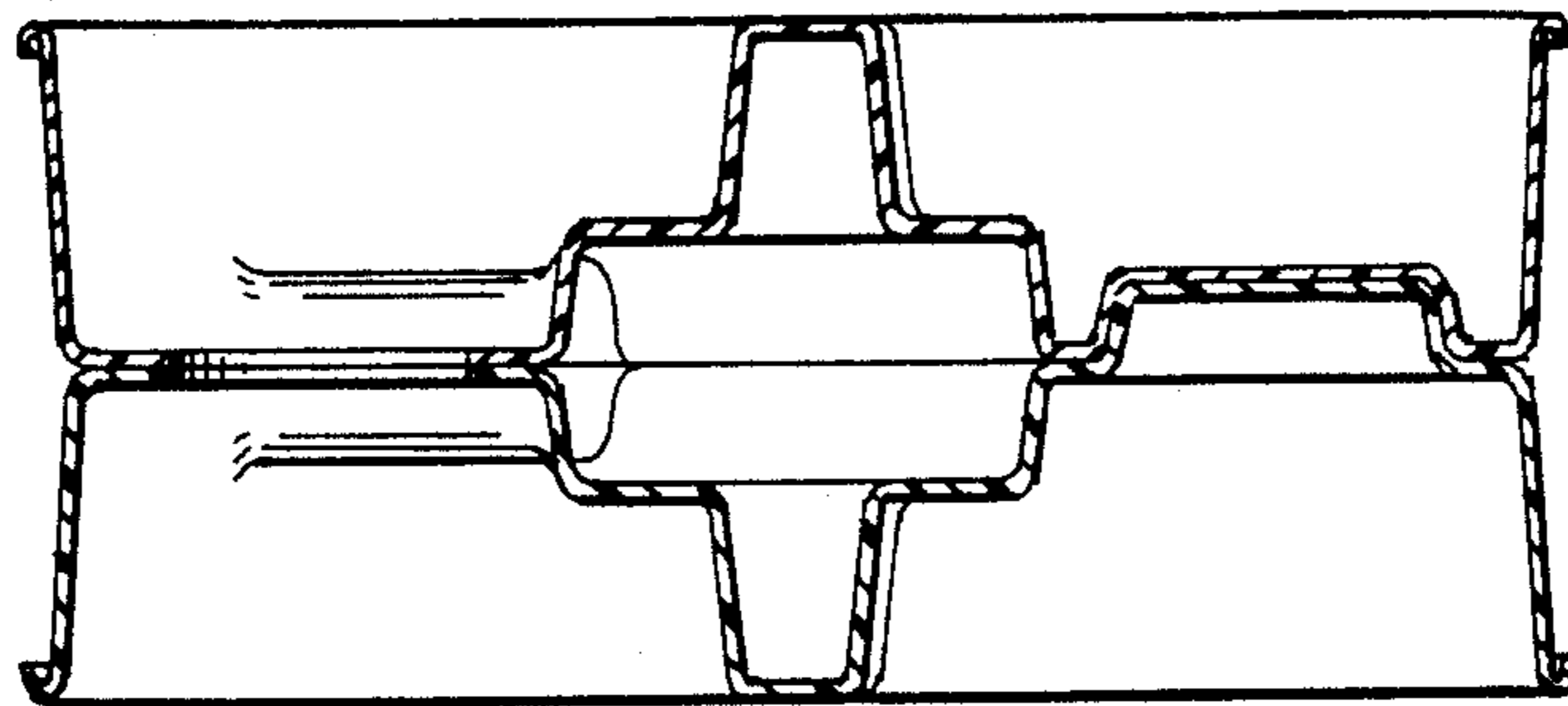
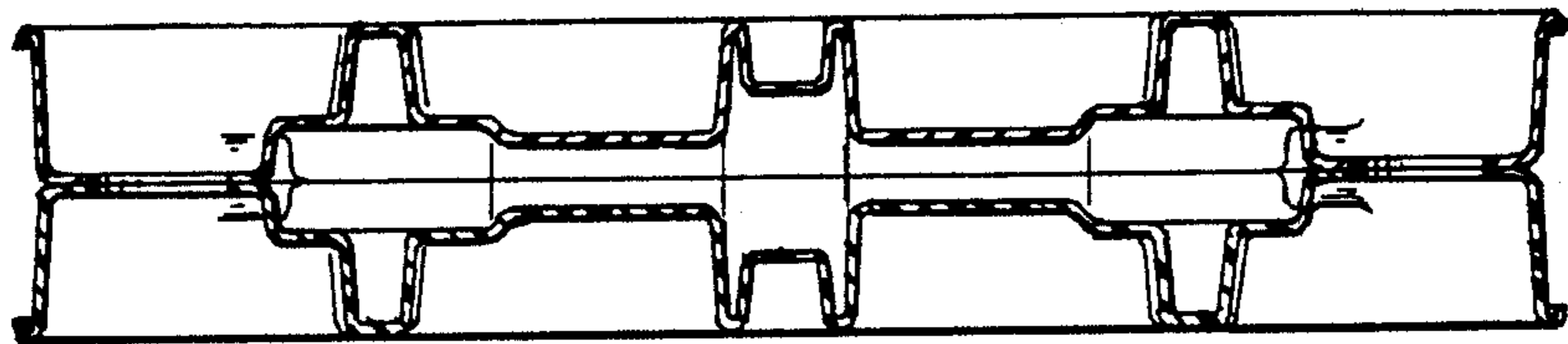

Fig 20