

[54] LICENSE PLATE FRAME

[76] Inventor: Paul Spencer, 2908 Oregon Ct., Ste. I-1, Torrance, Calif. 90503

[\*\*] Term: 14 Years

[21] Appl. No.: 156,087

[22] Filed: Feb. 16, 1988

[52] U.S. Cl. .... D12/193

[58] Field of Search ..... D12/193; D6/300, 303; 40/200, 207, 209, 201

[56] References Cited

U.S. PATENT DOCUMENTS

- D. 175,144 7/1955 Audette ..... D12/193
- 1,595,648 8/1926 Corley ..... D12/193

Primary Examiner—James M. Gandy  
Attorney, Agent, or Firm—Timothy T. Tyson

[57] CLAIM

The ornamental design for a license plate frame, as shown and described.

DESCRIPTION

FIG. 1 is a perspective view of a license plate frame showing one embodiment of my new design;  
 FIG. 2 is an enlarged front elevational view thereof;  
 FIG. 3 is an enlarged rear elevational view thereof;  
 FIG. 4 is an enlarged left side elevational view thereof;  
 FIG. 5 is an enlarged right side elevational view thereof;  
 FIG. 6 is an enlarged top plan view thereof;  
 FIG. 7 is an enlarged bottom plan view thereof;  
 FIG. 8 is a perspective view of a license plate frame showing a second embodiment of my new design;  
 FIG. 9 is an enlarged front elevational view of FIG. 8;  
 FIG. 10 is an enlarged rear elevational view of FIG. 8;  
 FIG. 11 is an enlarged left side elevational view of FIG. 8;  
 FIG. 12 is an enlarged right side elevational view of FIG. 8;  
 FIG. 13 is an enlarged top plan view of FIG. 8; and  
 FIG. 14 is an enlarged bottom plan view of FIG. 8.

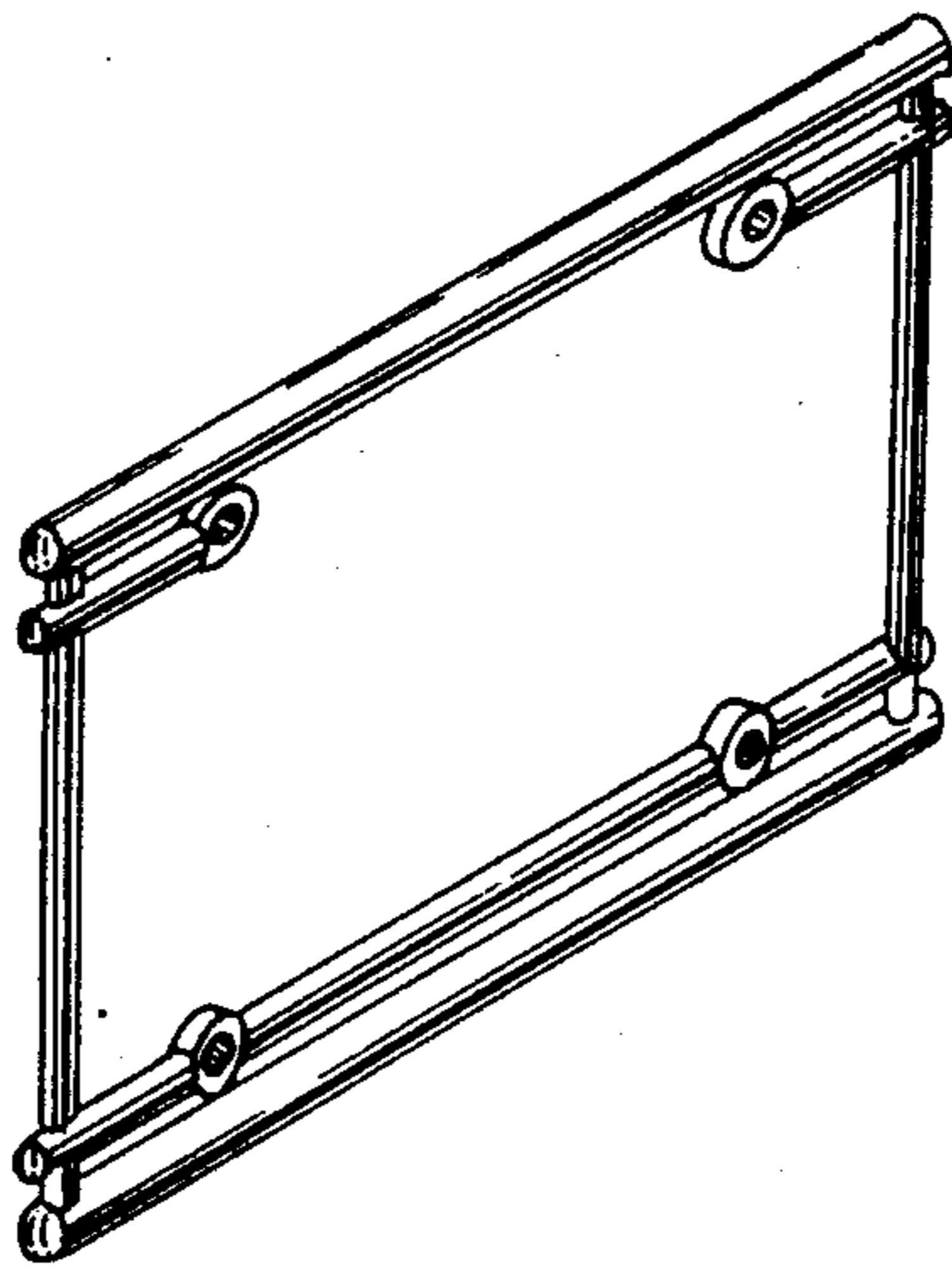

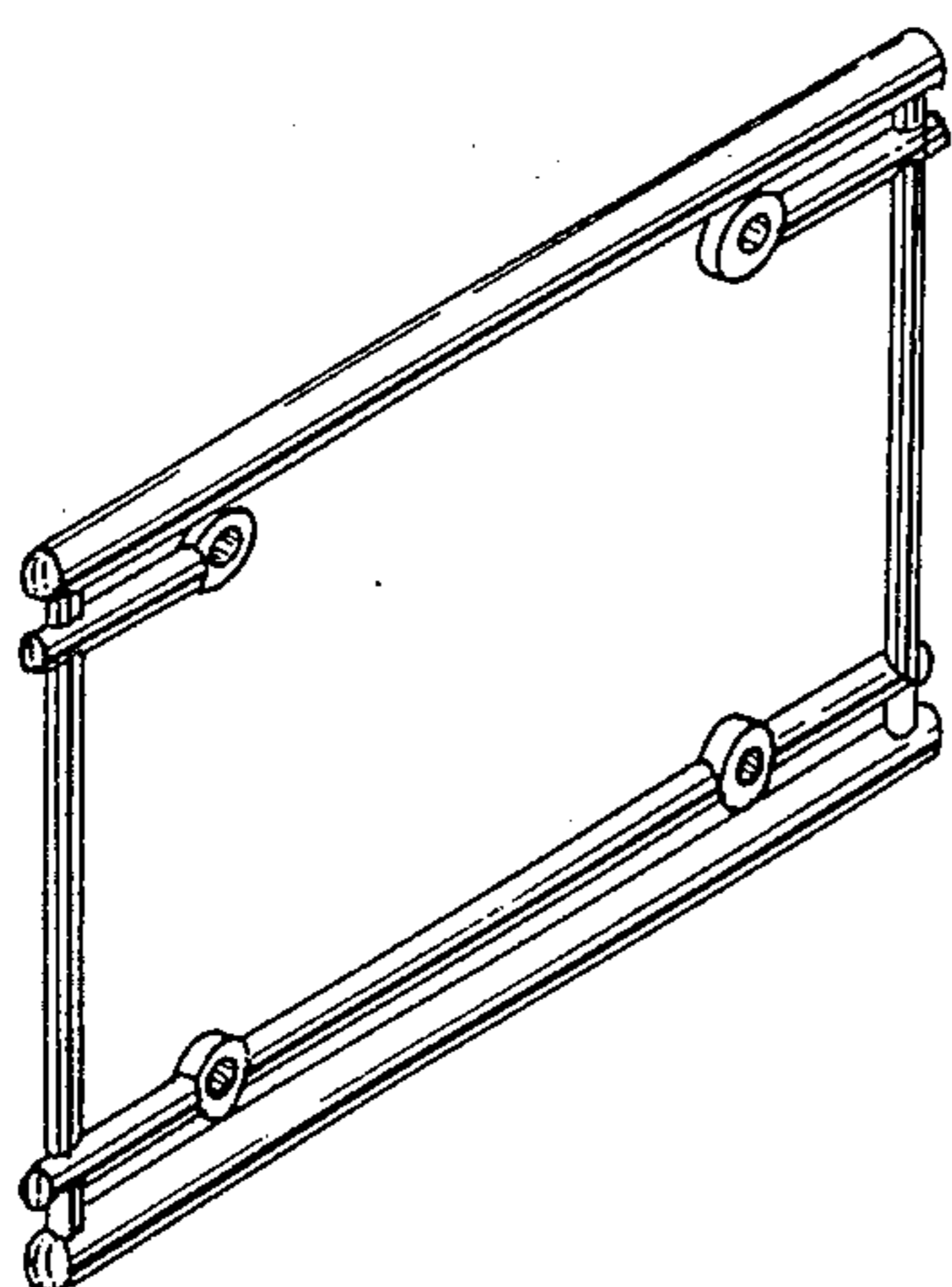

FIG. 1

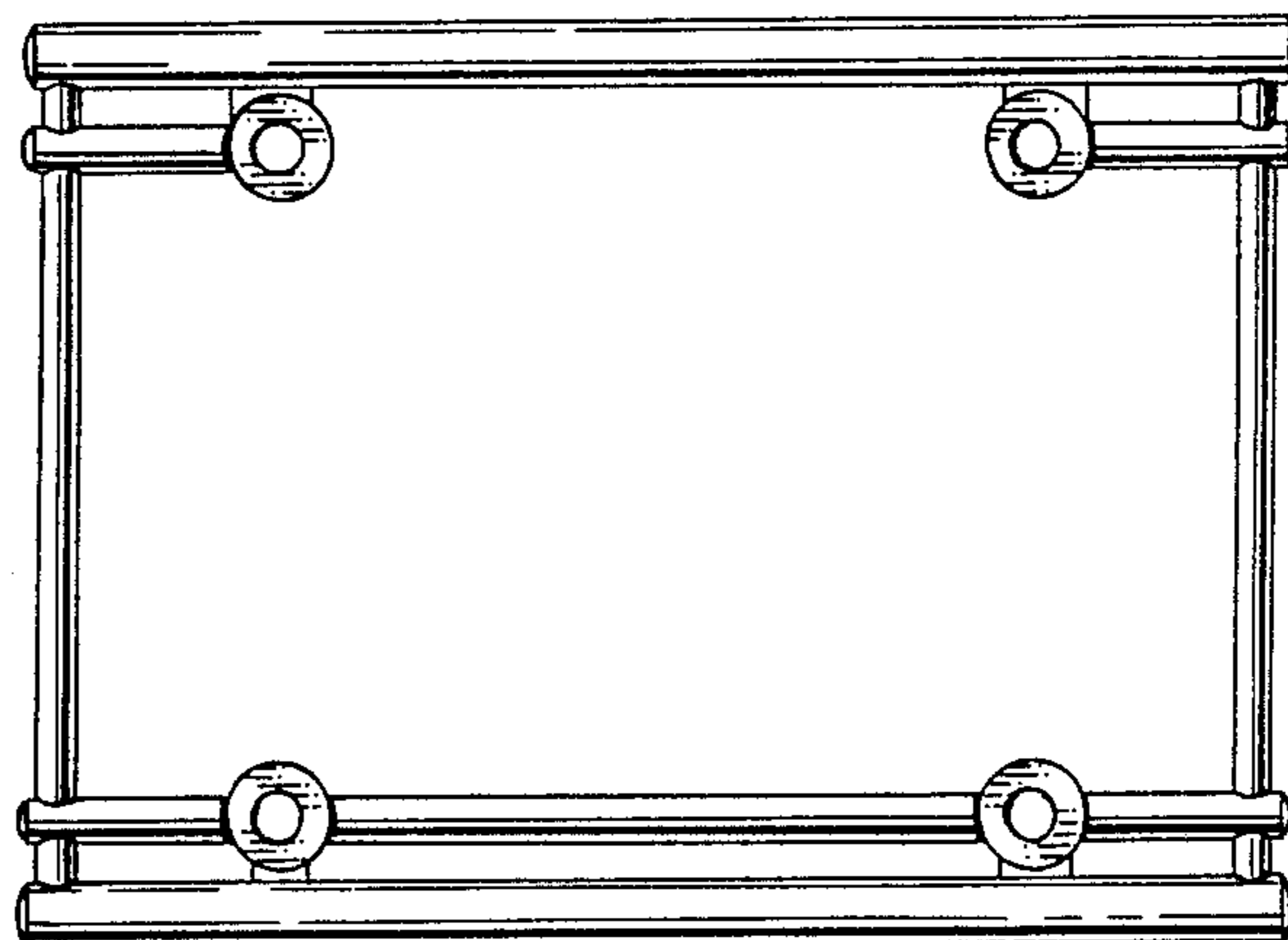

FIG. 2



FIG. 4



FIG. 5

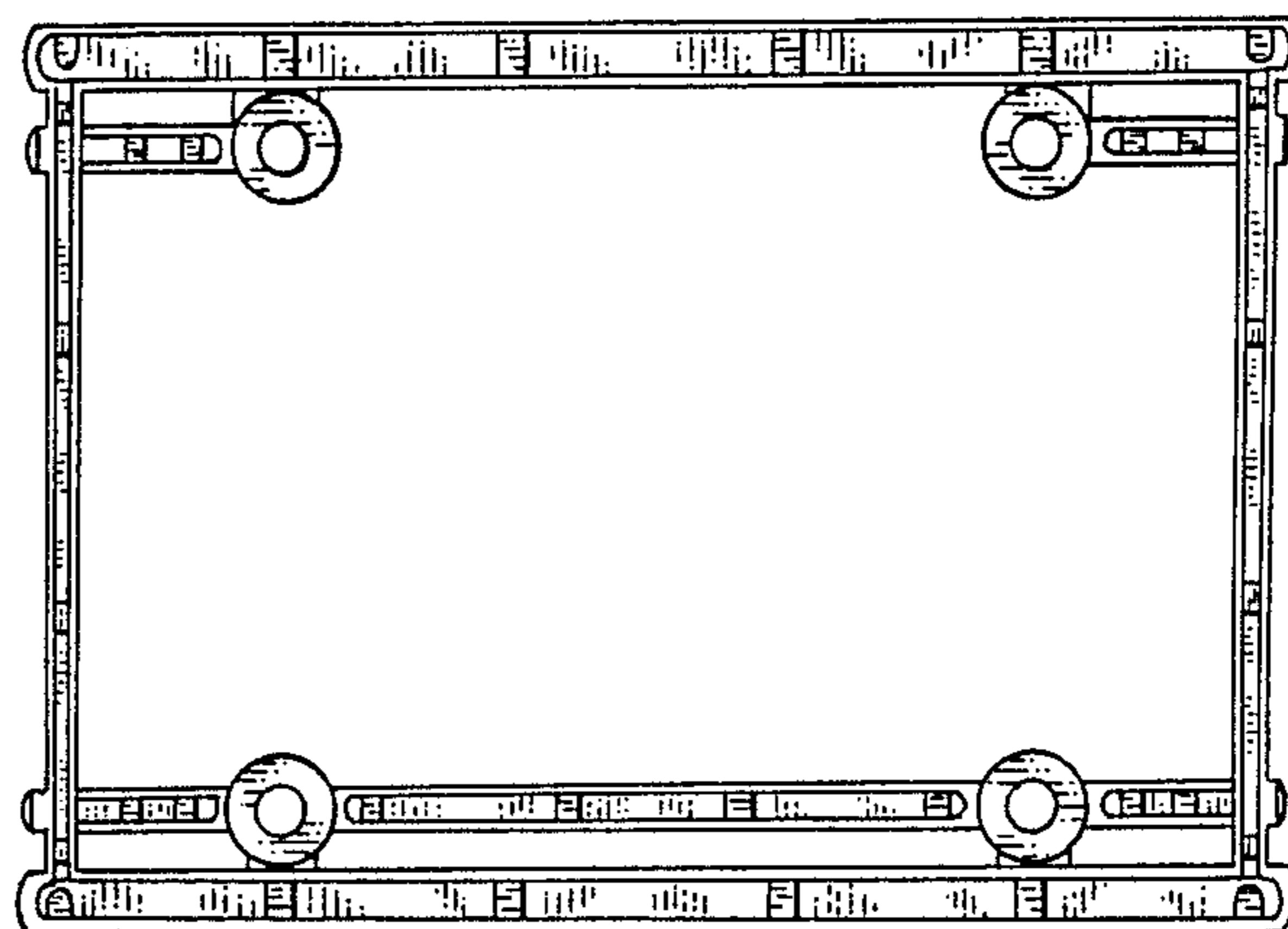

FIG. 3

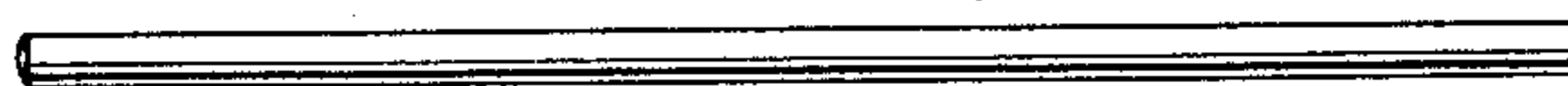

FIG. 6

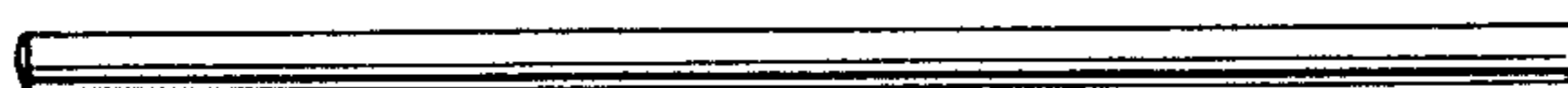

FIG. 7

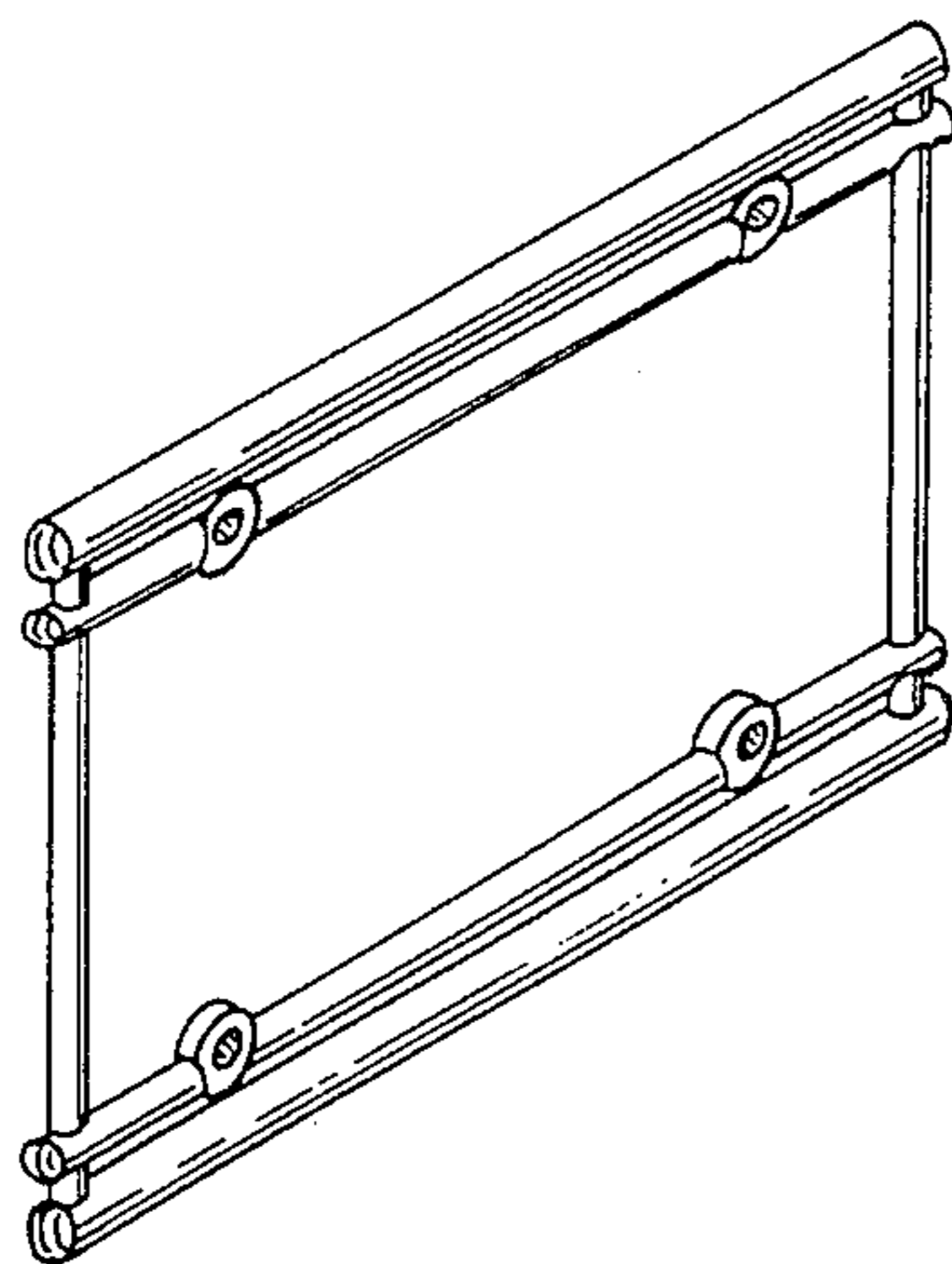

FIG. 8

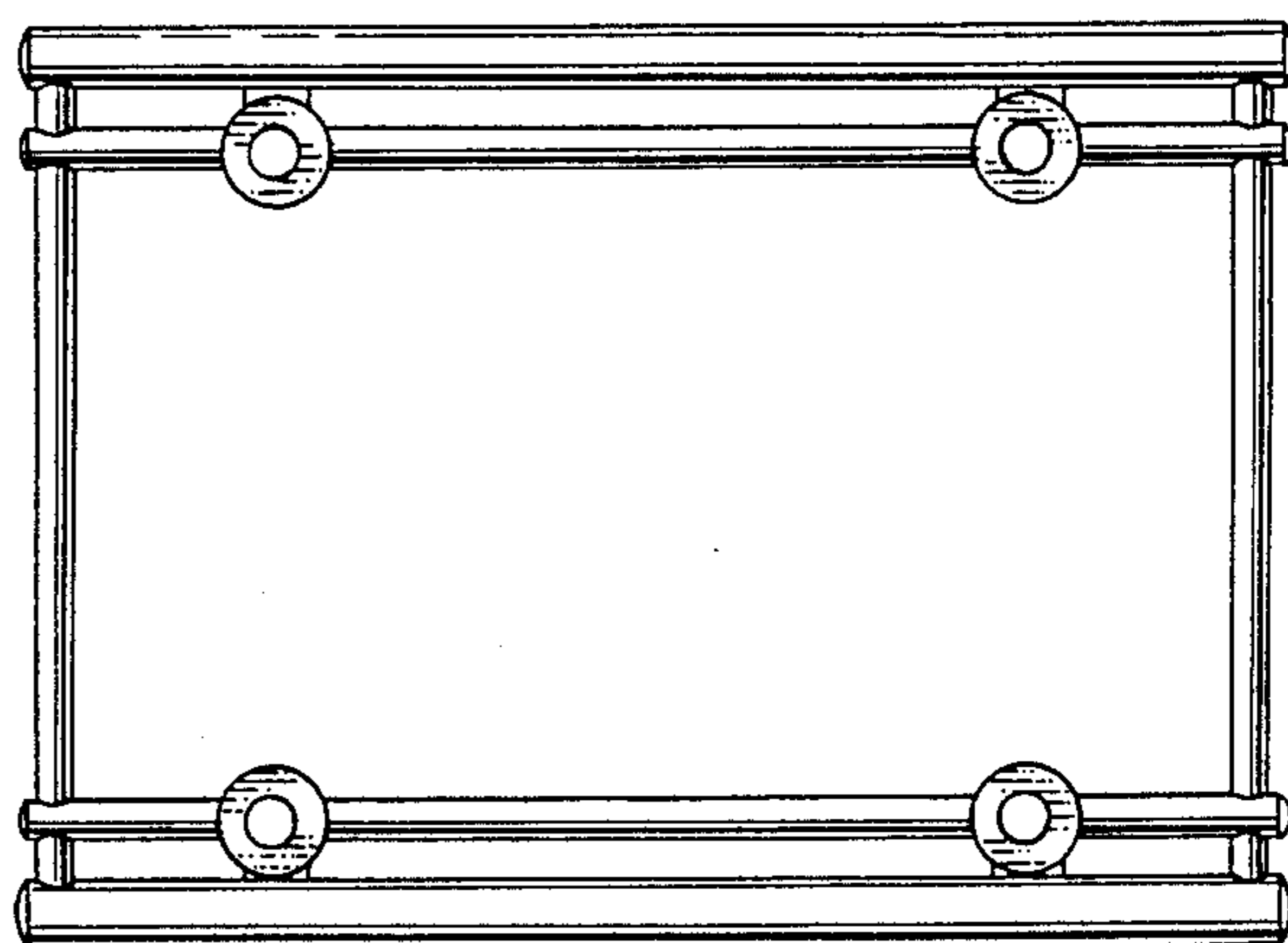

FIG. 9



FIG. 11



FIG. 12

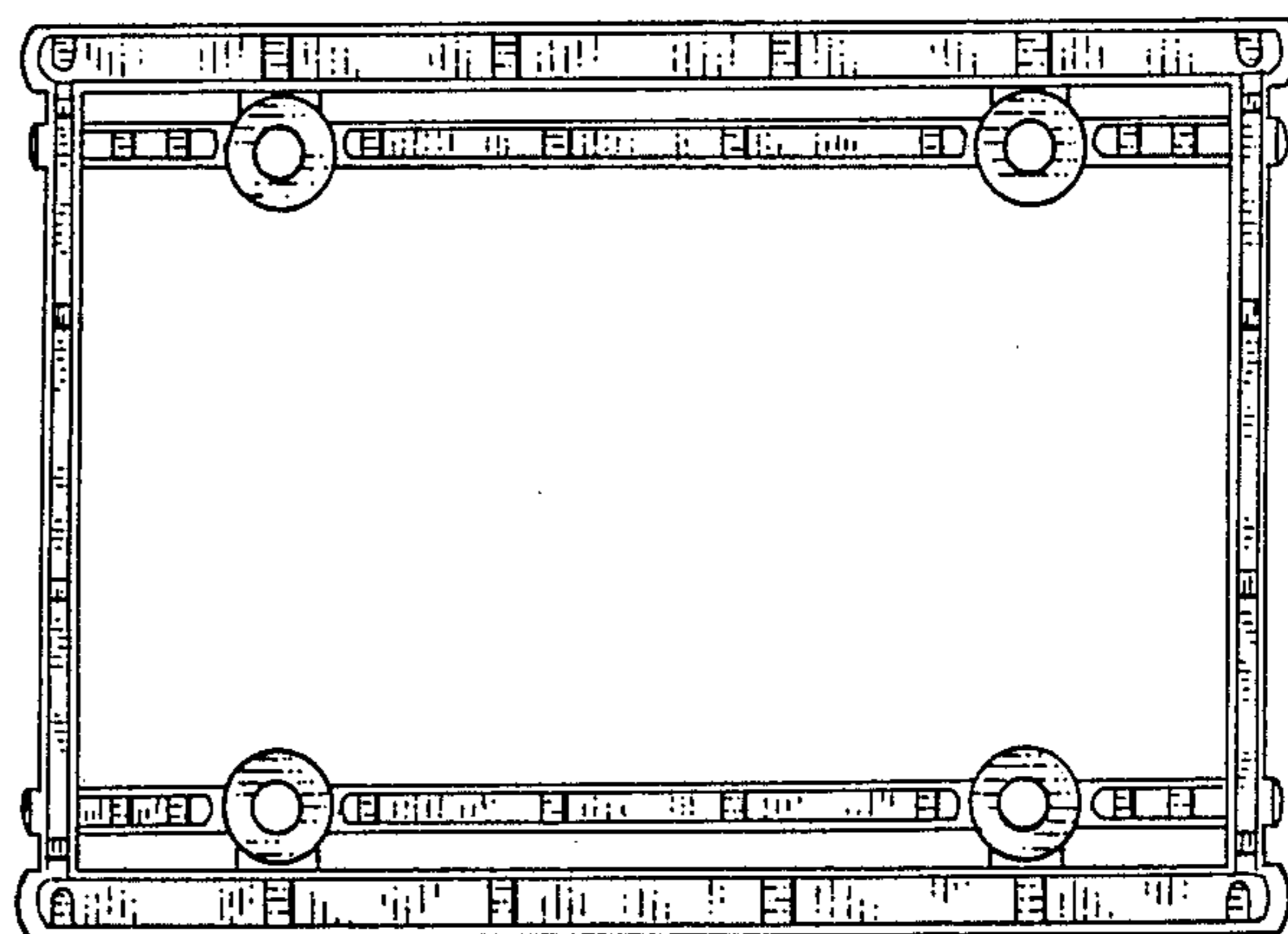

FIG. 10

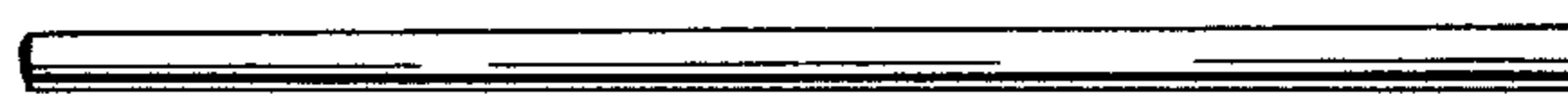

FIG. 13

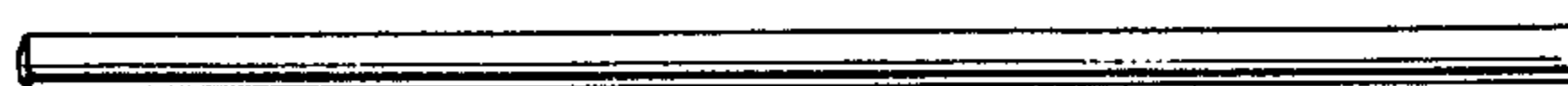

FIG 14