

[54] COMBINATION TRUCK BED LINER AND CONVERTIBLE CUSHION UNIT

Attorney, Agent, or Firm—Gifford, Groh, Sprinkle, Patmore and Anderson

[76] Inventor: Michael Angerer, 26666 Rosehill, Farmington Hills, Mich. 48018

[57] CLAIM

The ornamental design of a combination truck bed liner and convertible cushion unit, as shown and described.

[**] Term: 14 Years

DESCRIPTION

[21] Appl. No.: 19,343

[22] Filed: Feb. 26, 1987

[52] U.S. Cl. D12/98; D6/356; D6/367

[58] Field of Search D6/356; D12/98, 156; 296/37.6, 39.1, 24.1

[56] References Cited

U.S. PATENT DOCUMENTS

- D. 249,494 9/1978 Lambitz D12/98
- D. 298,112 10/1988 Hall D12/98

OTHER PUBLICATIONS

Commercial Carrier Journal, Aug. 1983, p. 92, pick-up bed liner, top of page.

Primary Examiner—Bruce W. Dunkins

Assistant Examiner—Ann Hunt

FIG. 1 is a rear perspective view of the combination truck bed liner and convertible cushion unit showing my new design in use as a seat;

FIG. 2 is a rear perspective view thereof in use as a sleeping surface;

FIG. 3 is a rear perspective view thereof showing the cushion elements removed;

FIG. 4 is a partial top plan view with the cushion elements in position as in FIG. 2;

FIG. 5 is a broken away plan view of the right side showing cushion elements removed as seen in FIG. 3;

FIG. 6 is an elevational view taken along line 6—6 of FIG. 4;

FIG. 7 is a cross sectional view taken along line 7—7 of FIG. 5; and

FIG. 8 is a cross sectional view taken along line 8—8 of FIG. 4 with the cushion elements in position as in FIG. 1.

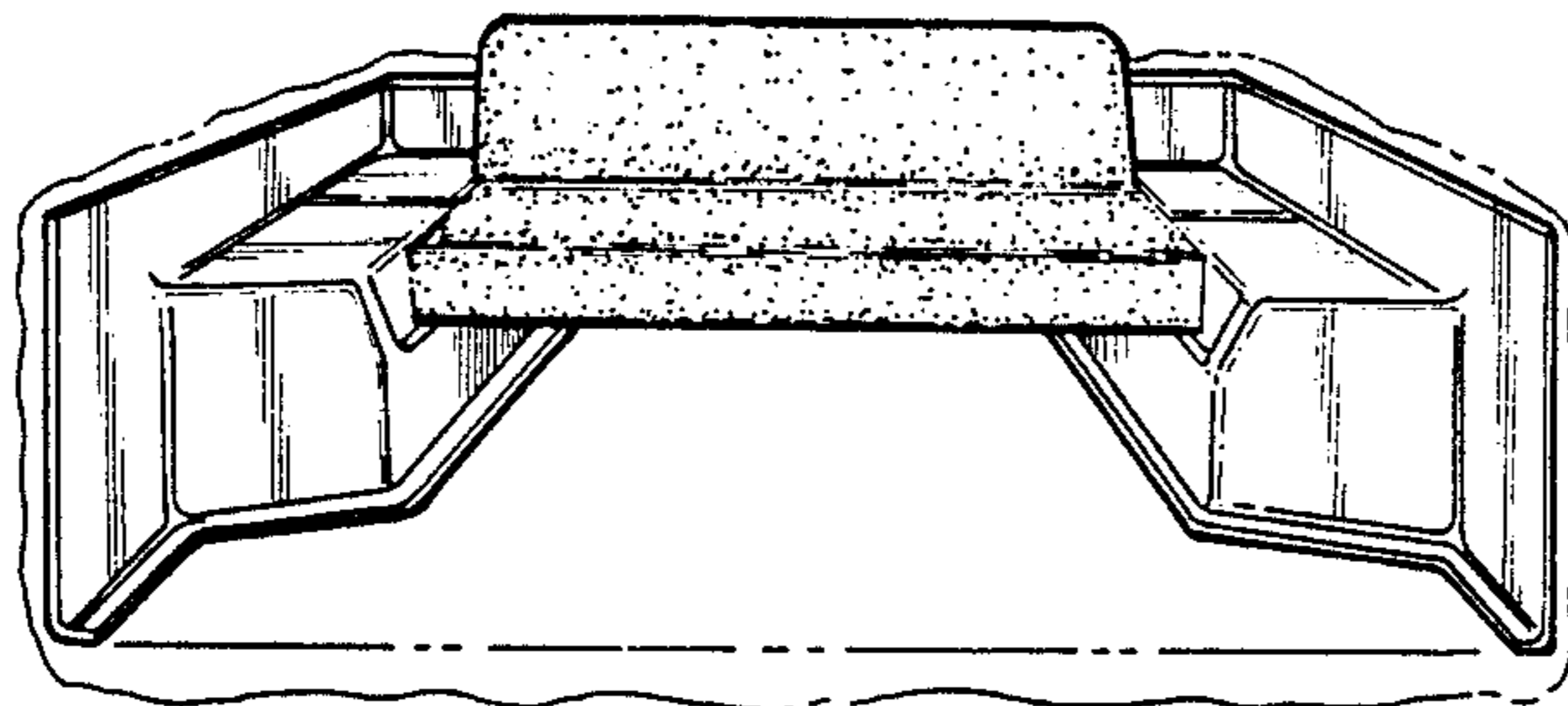
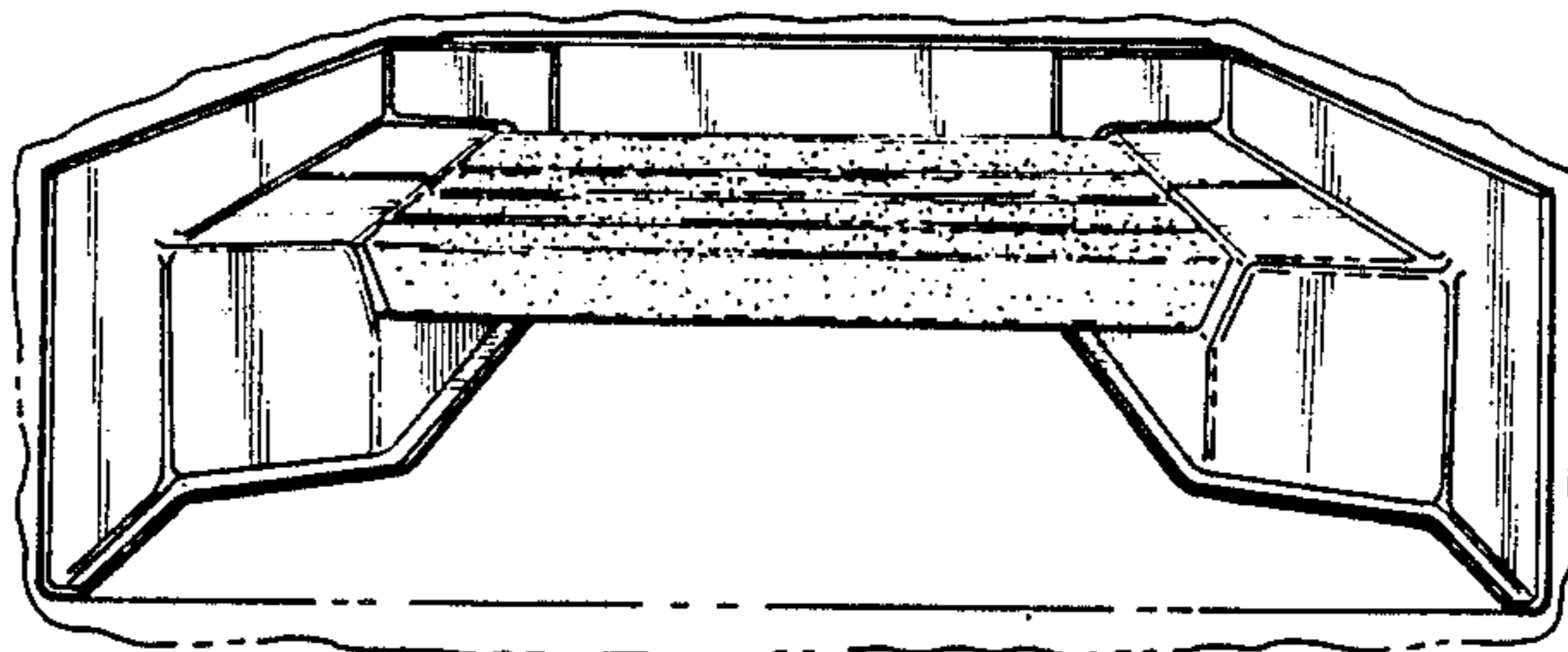

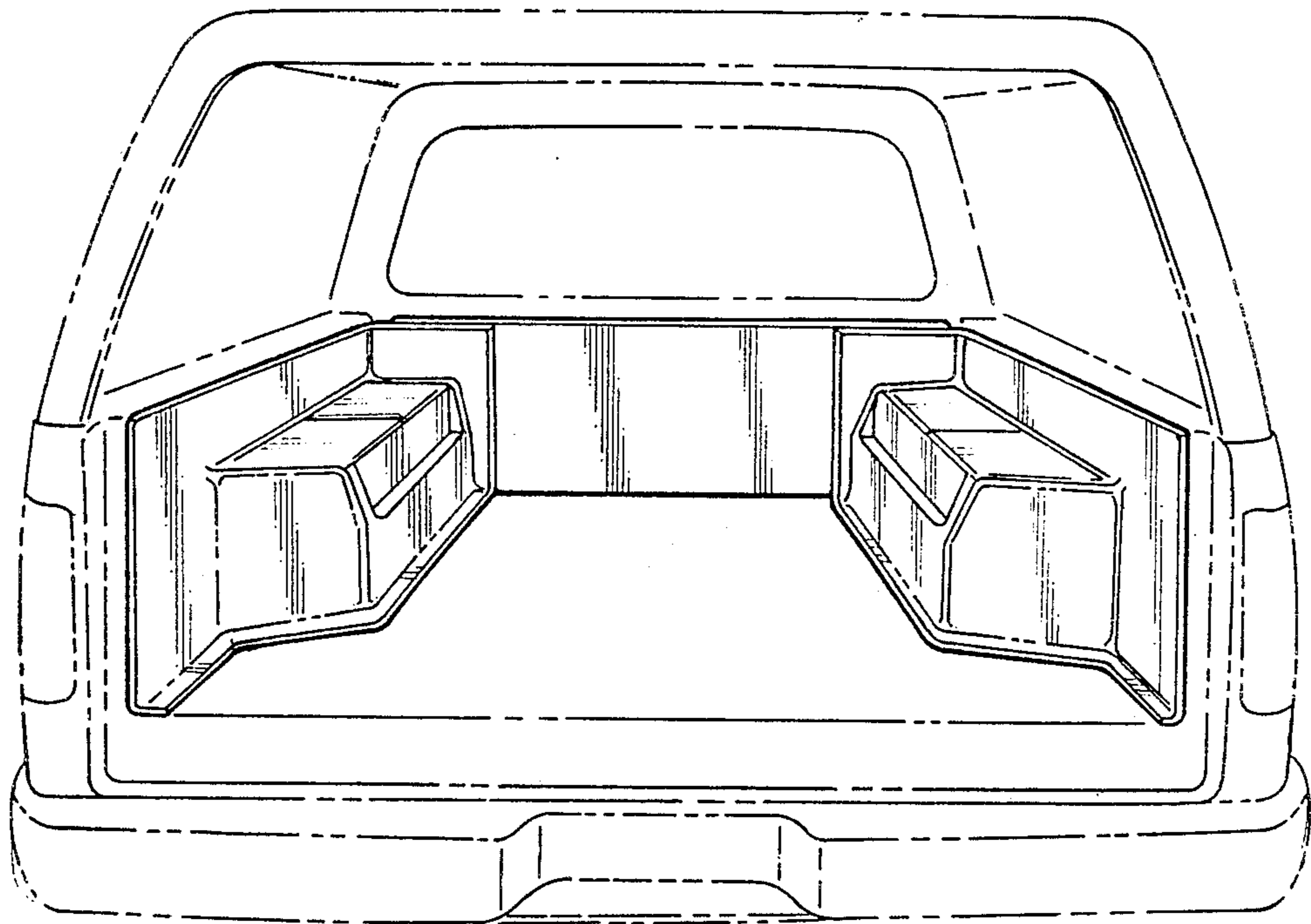

Fig-3

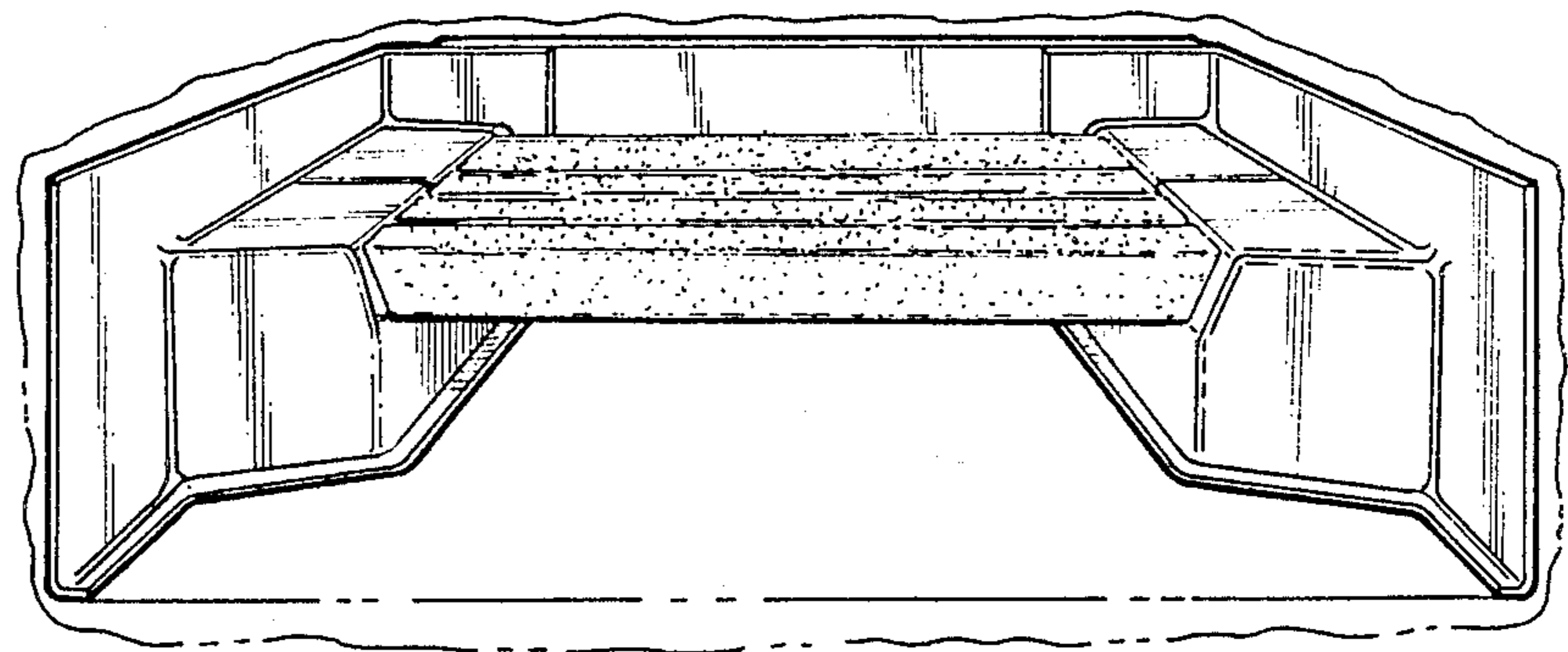

Fig-2

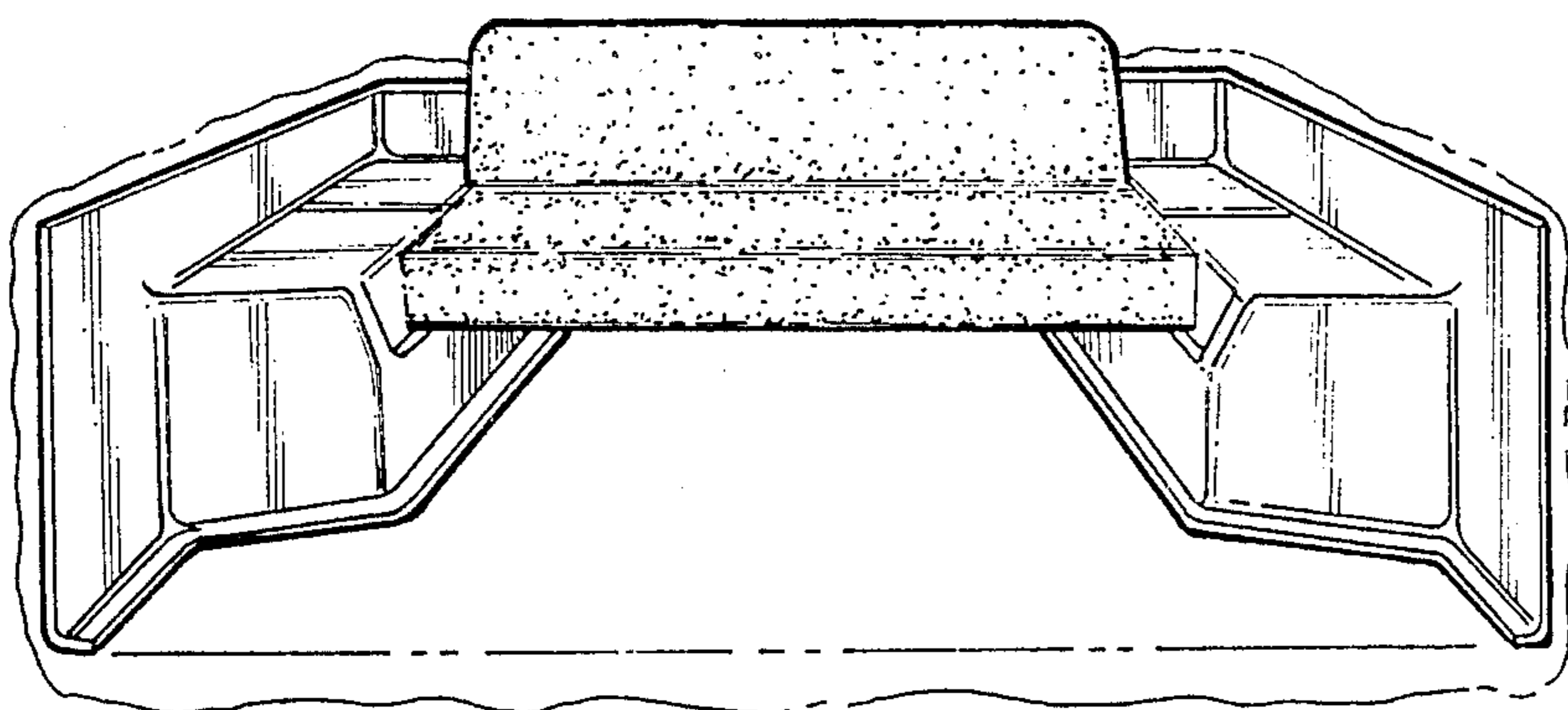

Fig-1

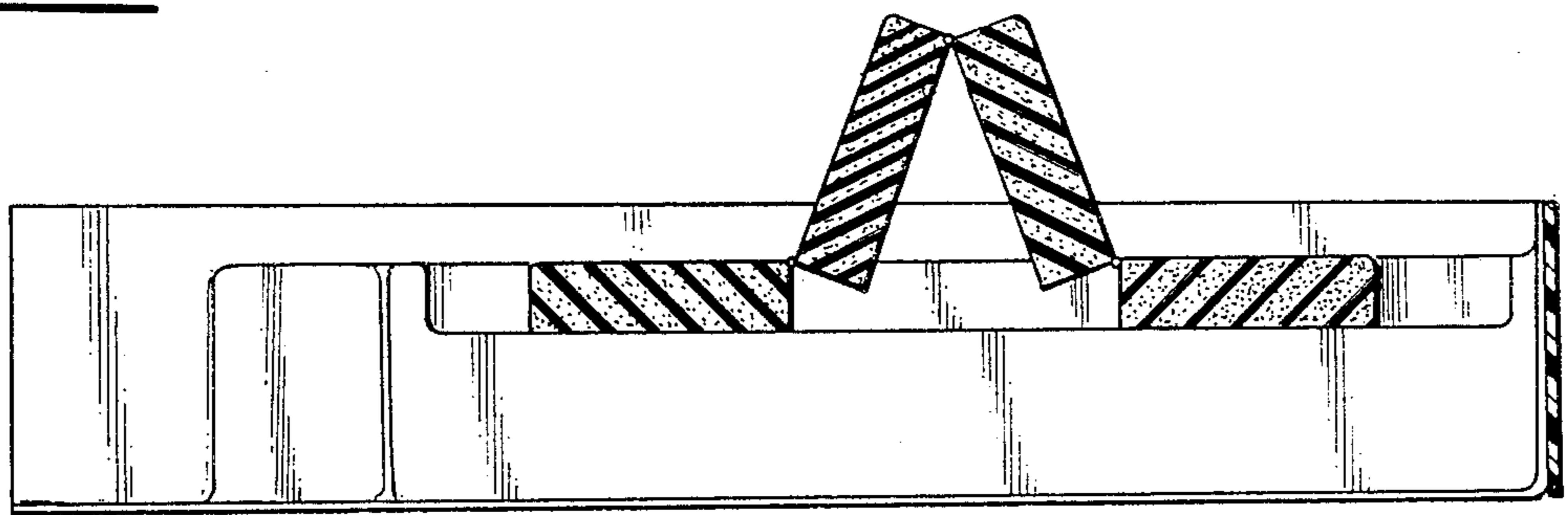
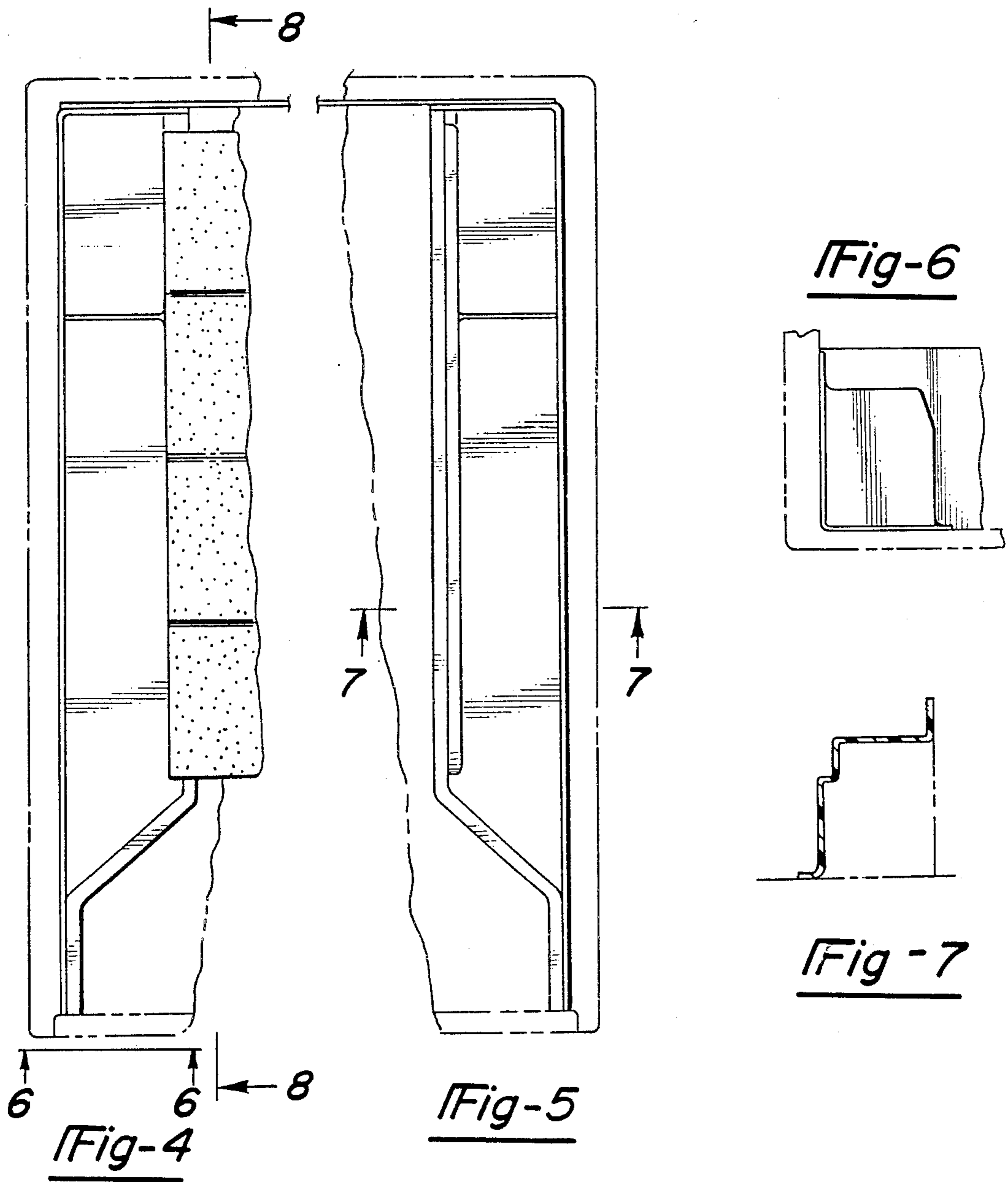

Fig-8