

[54] WALL MOUNTED ARTICLE STORAGE SHELF

[76] Inventor: Maxine T. Keel, Rte. 3, Box 281, Ashford, Ala. 36312

[**] Term: 14 Years

[21] Appl. No.: 896,336

[22] Filed: Aug. 13, 1986

[52] U.S. Cl. D8/380

[58] Field of Search D8/349, 354, 363, 366, D8/373, 374, 380; 248/300, 213.2, 309.1

[56] References Cited

U.S. PATENT DOCUMENTS

- D. 232,156 7/1974 Schoepe et al. D8/354 X
- D. 241,222 8/1976 Edwards D8/373 X
- D. 275,178 8/1984 Yeater D8/349 X

Primary Examiner—Susan J. Lucas

Assistant Examiner—M. H. Tung
Attorney, Agent, or Firm—Lowe, Price, LeBlanc,
Becker & Shur

[57] CLAIM

The ornamental design for a wall mounted article storage shelf, as shown.

DESCRIPTION

FIG. 1 is a perspective view of a wall mounted article storage shelf showing my new design, on a reduced scale, the broken lines of a beverage bar are shown for illustrative purposes only and form no part of the claimed design;

FIG. 2 is a perspective view thereof, on an enlarged scale;

FIG. 3 is a side elevational view thereof;

FIG. 4 is a front elevational view thereof;

FIG. 5 is a rear elevational view thereof;

FIG. 6 is a top plan view thereof;

FIG. 7 is a bottom plan view thereof.

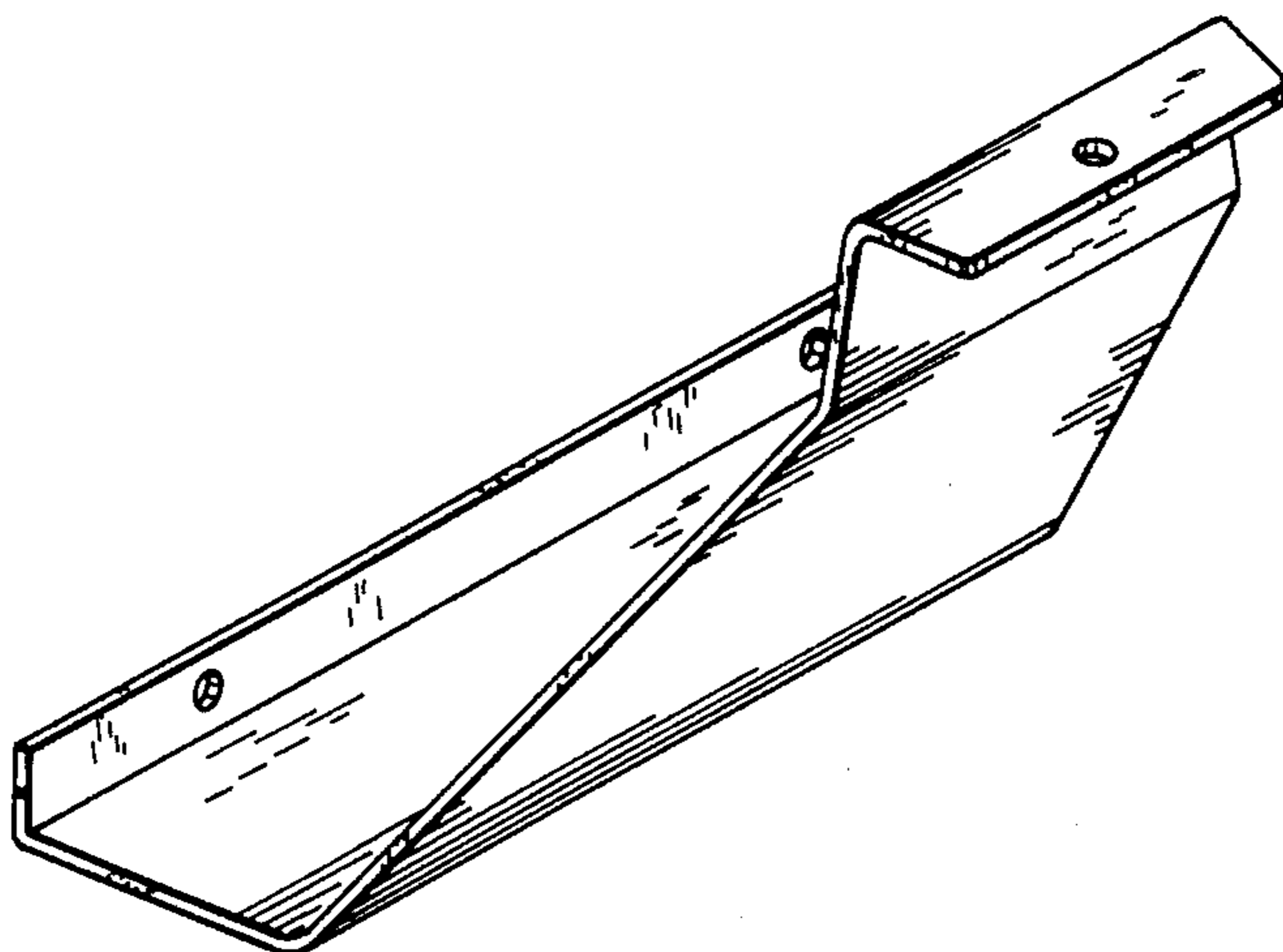

Fig. 1

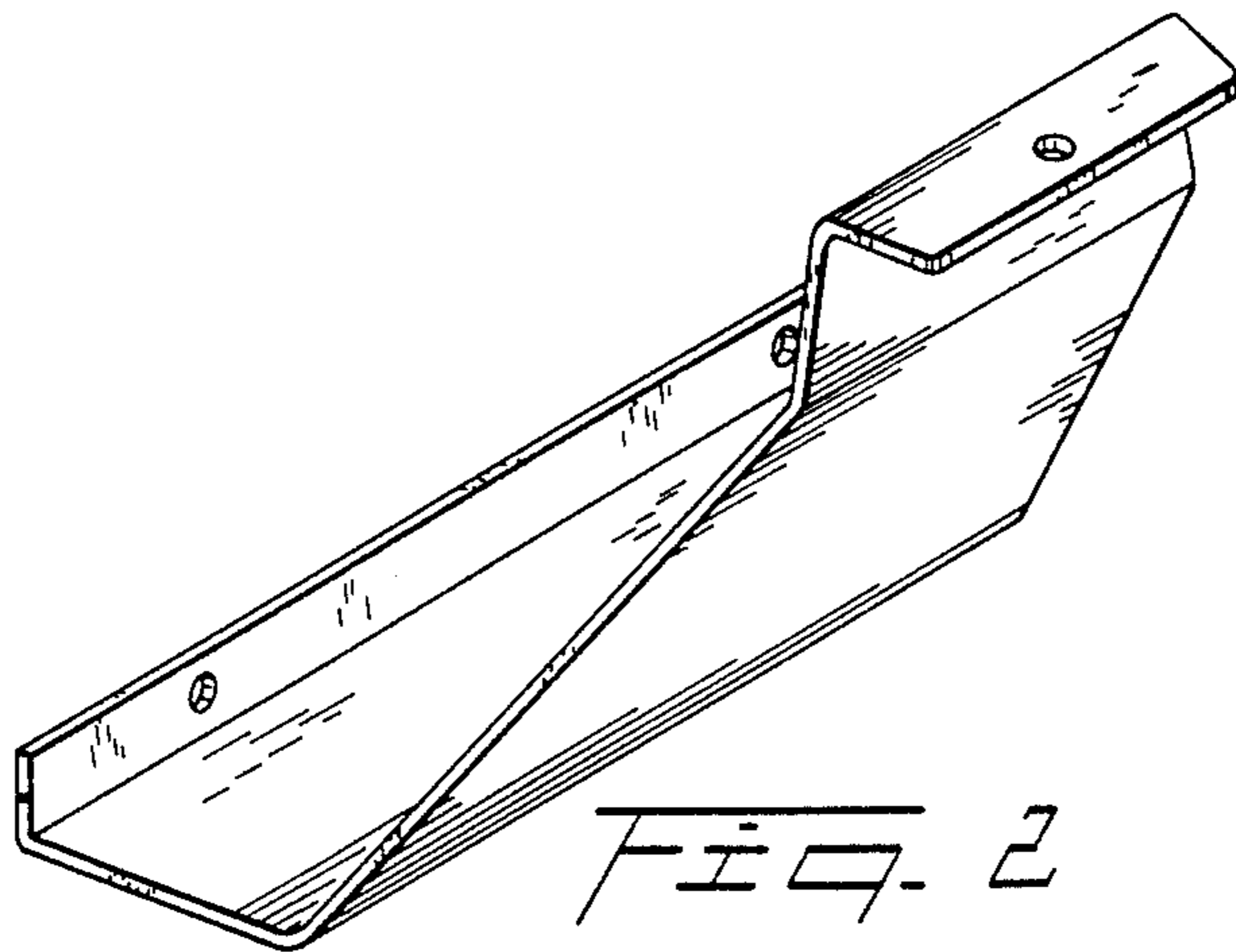
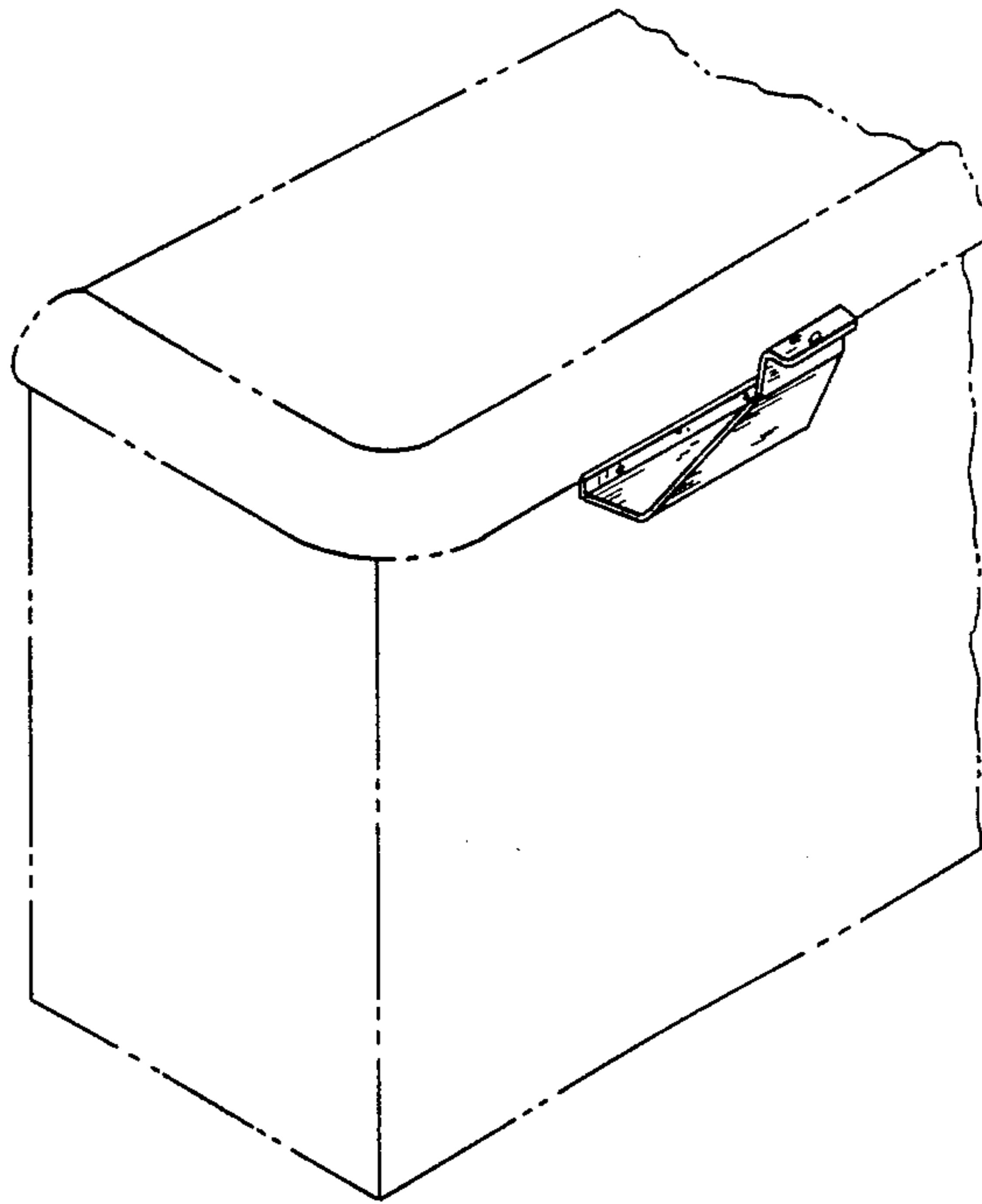

Fig. 2

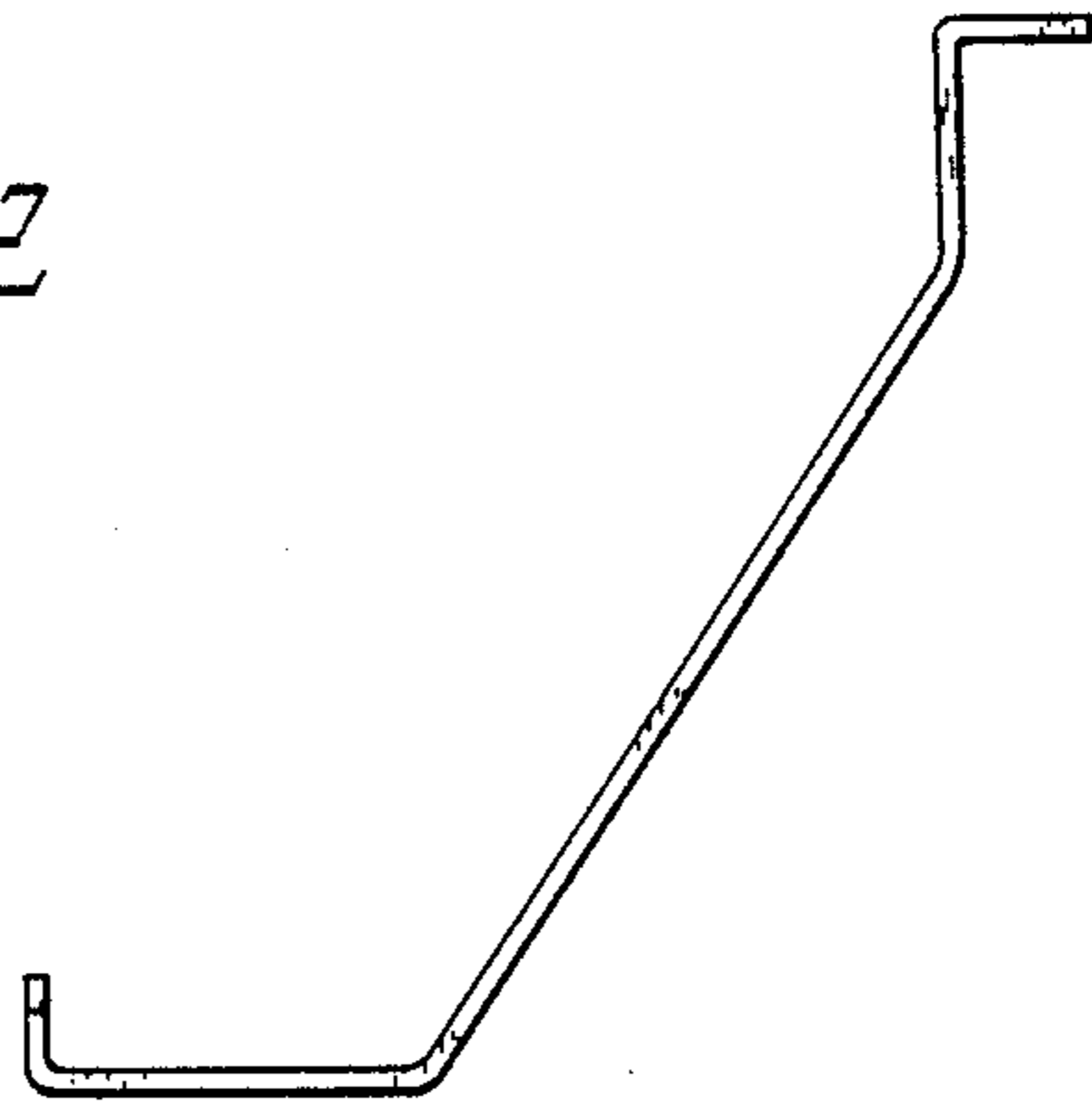

Fig. 3

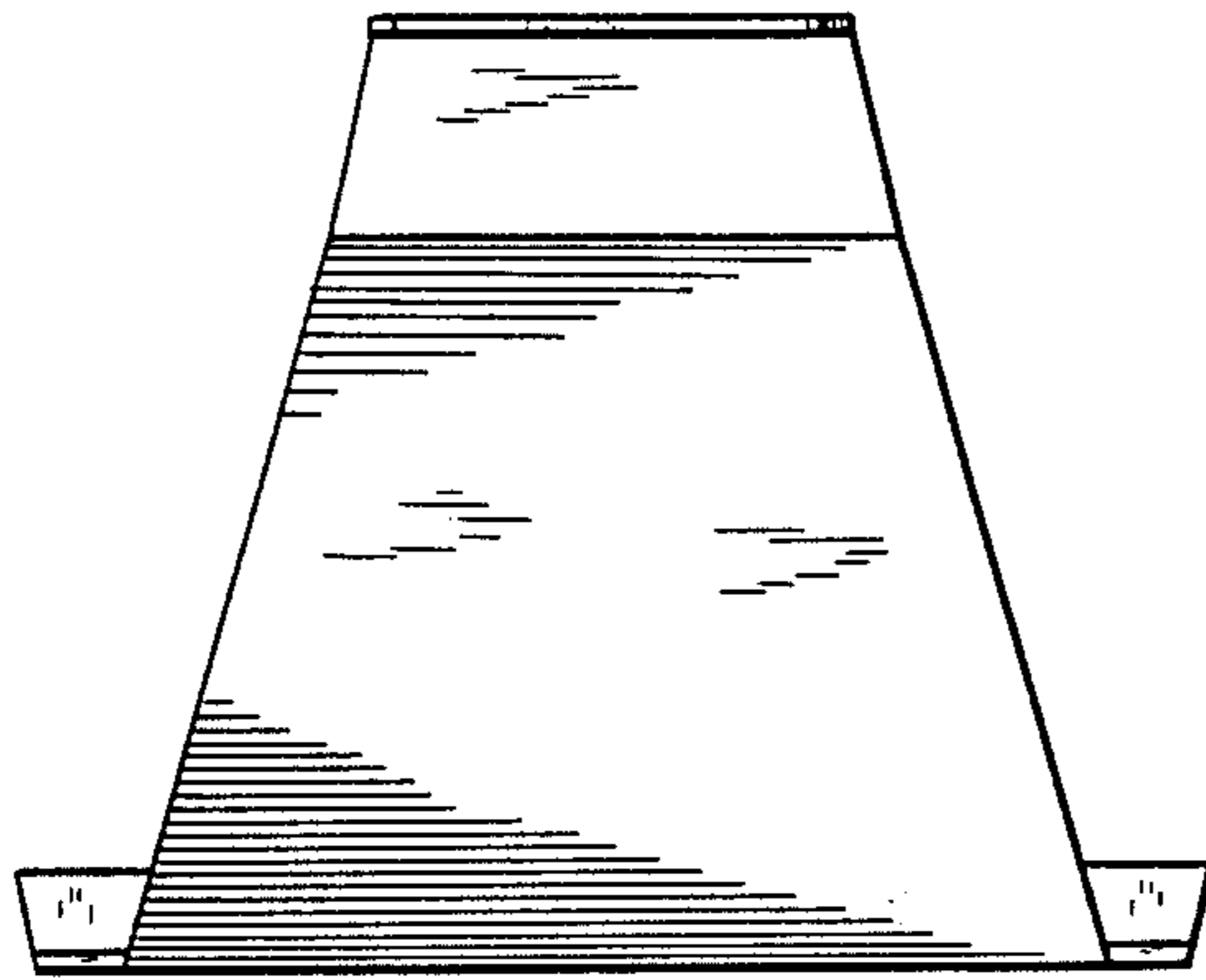

FIG. 4

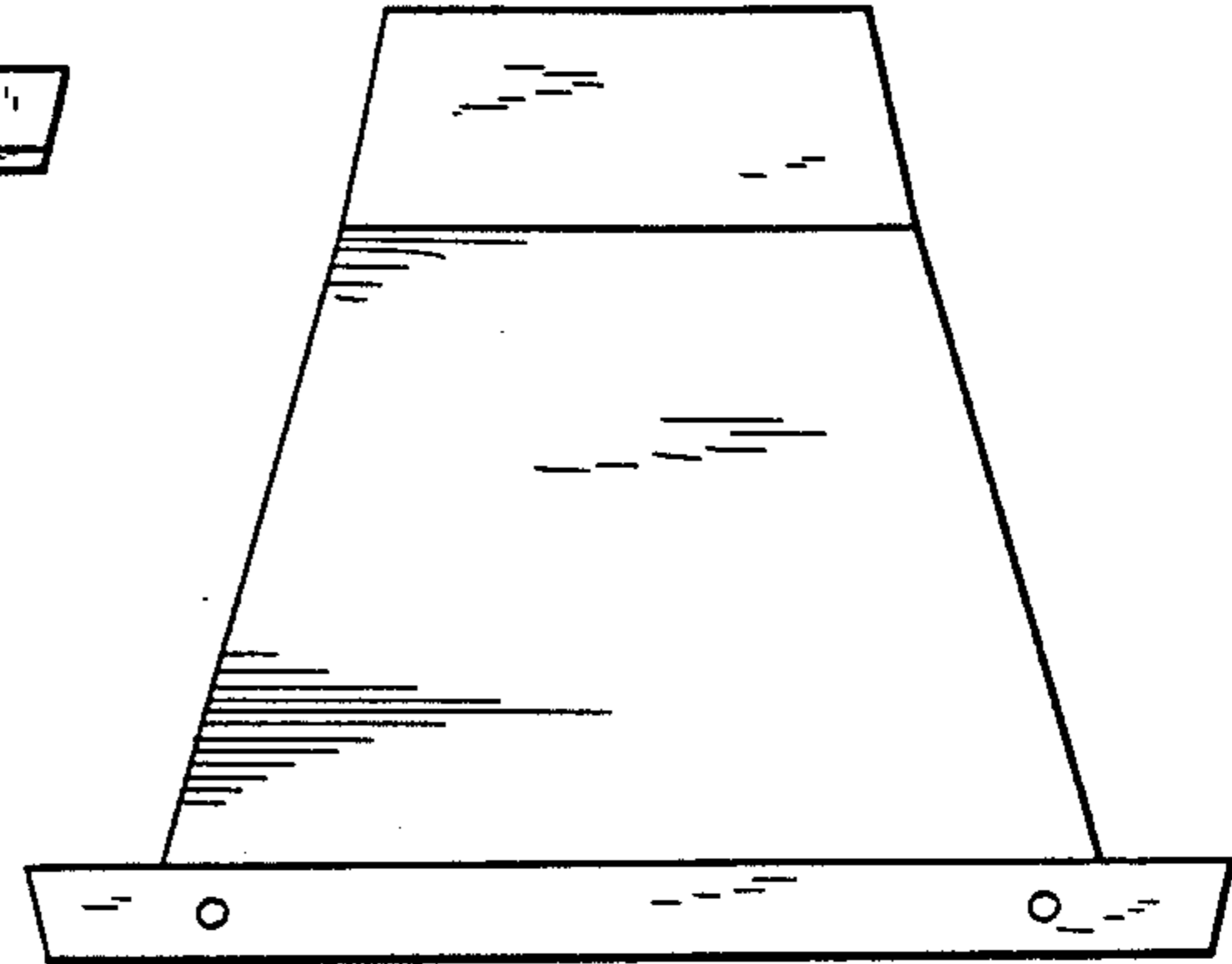

FIG. 5

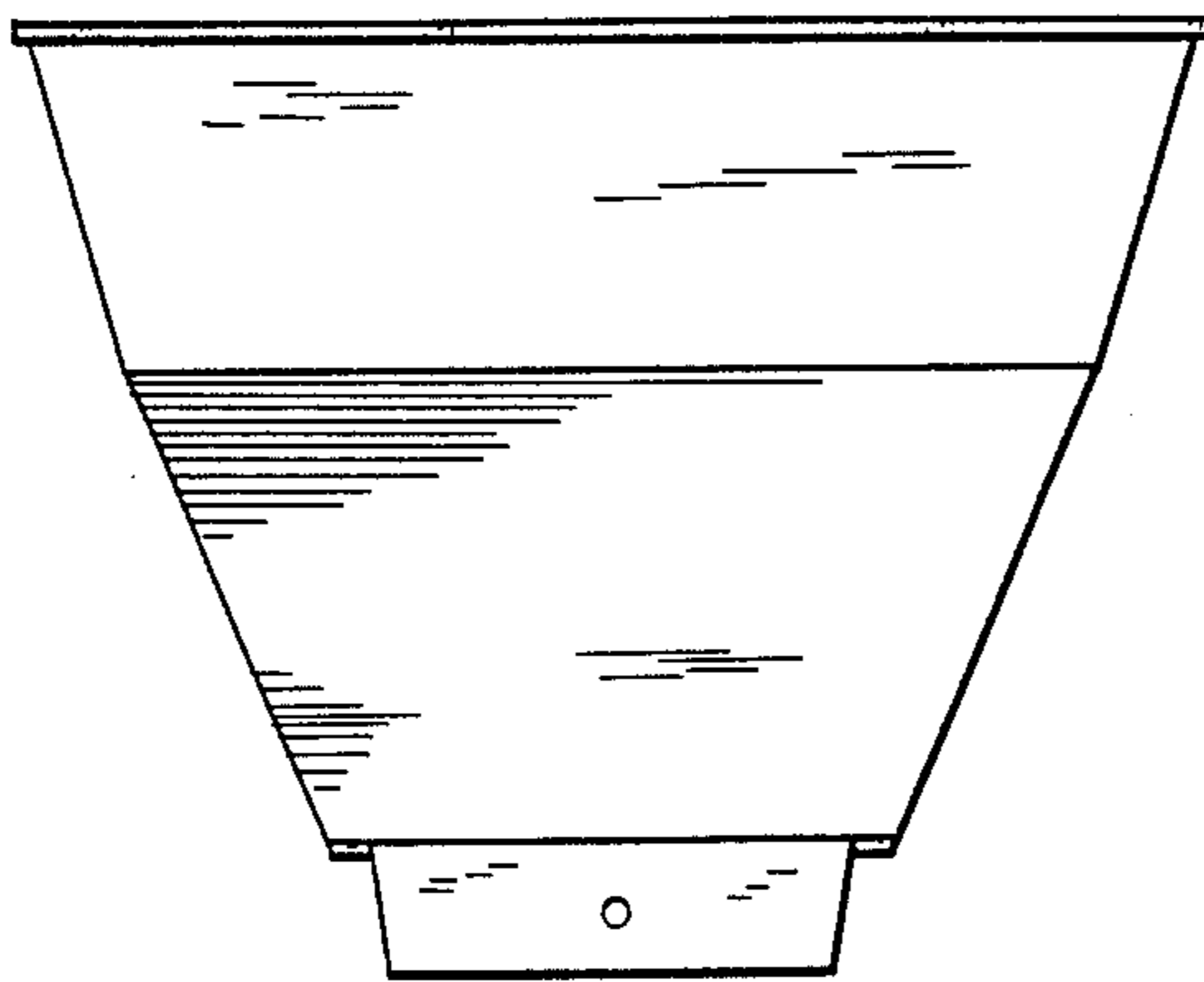

FIG. 6

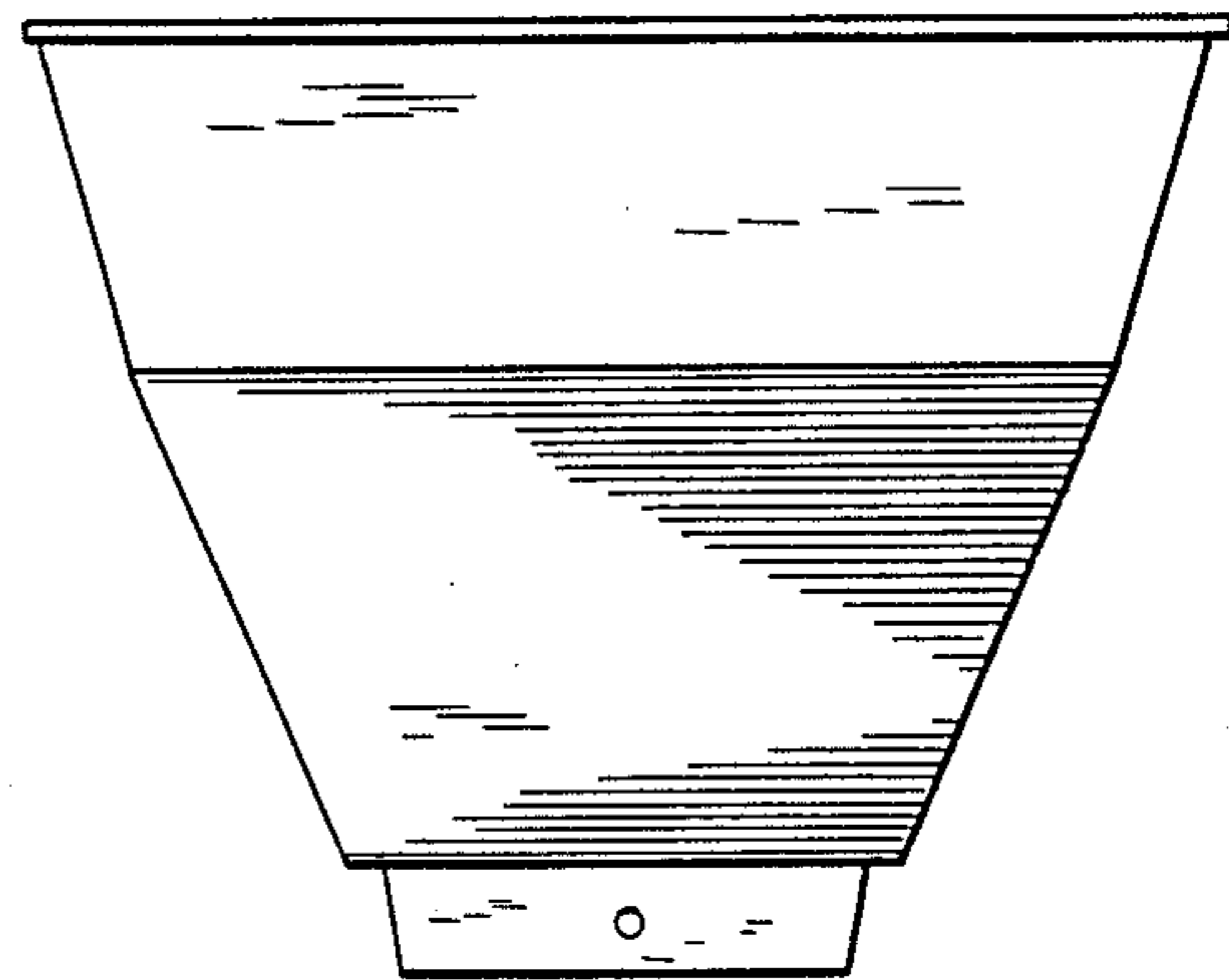

FIG. 7