

[54] LUG NUT HOLDER FOR TIRE
INSTALLATION OR REMOVAL

[76] Inventor: Edward K. Blair, P.O. Box k732,
Gardnerville, Nev. 89410

[**] Term: 14 Years

[21] Appl. No.: 90,149

[22] Filed: Aug. 26, 1986

[52] U.S. Cl. D8/71; D8/14

[58] Field of Search D8/14, 21-29,
D8/71; 81/15.3; 248/544, 547; 211/69, 69.5,
70.1, 70.8

[56] References Cited

U.S. PATENT DOCUMENTS

- D. 135,425 4/1943 McLaren D8/71
- D. 218,910 10/1970 Gargrave D8/71
- D. 280,284 8/1985 Bachmann D8/71

4,579,485 4/1986 Connor et al. D8/71 X

Primary Examiner—Bruce W. Dunkins
Assistant Examiner—Clare E. Heflin
Attorney, Agent, or Firm—Herbert C. Schulze

[57] CLAIM

The ornamental design for a lug nut holder for tire installation or removal, as shown and described.

DESCRIPTION

FIG. 1 is a perspective of the lug nut holder for tire installation or removal embodying my new design; FIG. 2 is a rear elevation thereof; FIG. 3 is a right side elevation thereof; FIG. 4 is a left side elevation thereof; FIG. 5 is a top plan view thereof; FIG. 6 is a bottom plan view thereof; and FIG. 7 is a perspective view thereof, the lug nuts and wrench being shown in broken lines for illustrative purposes only.

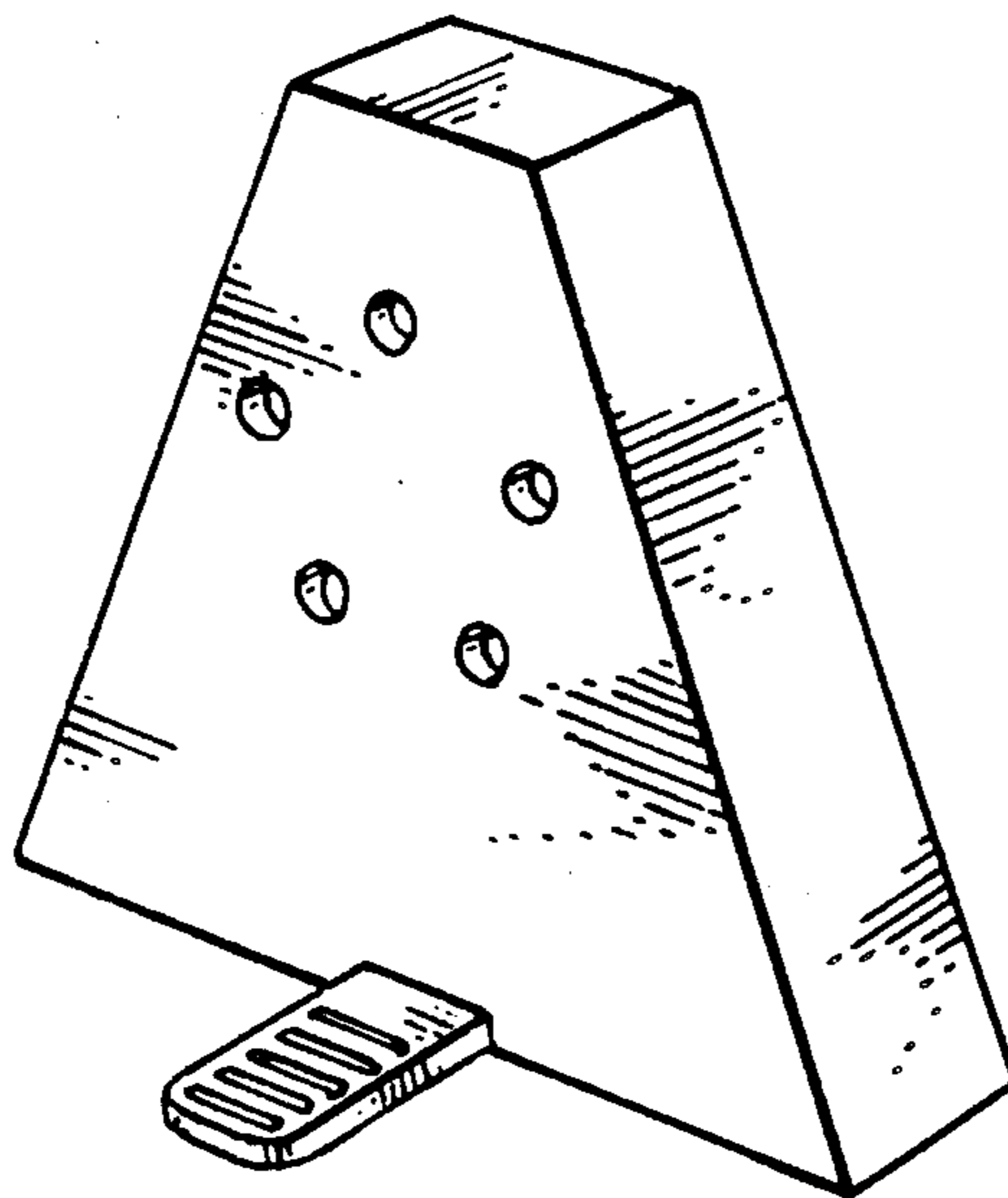

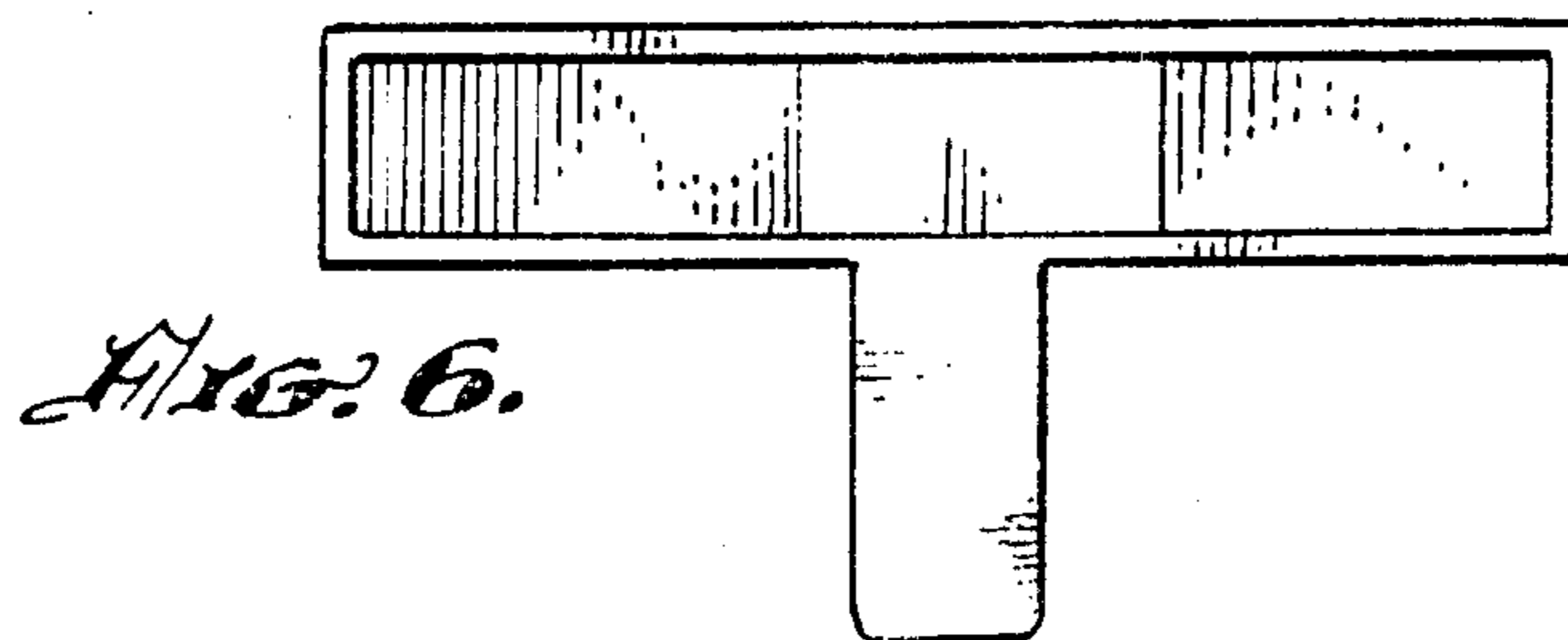
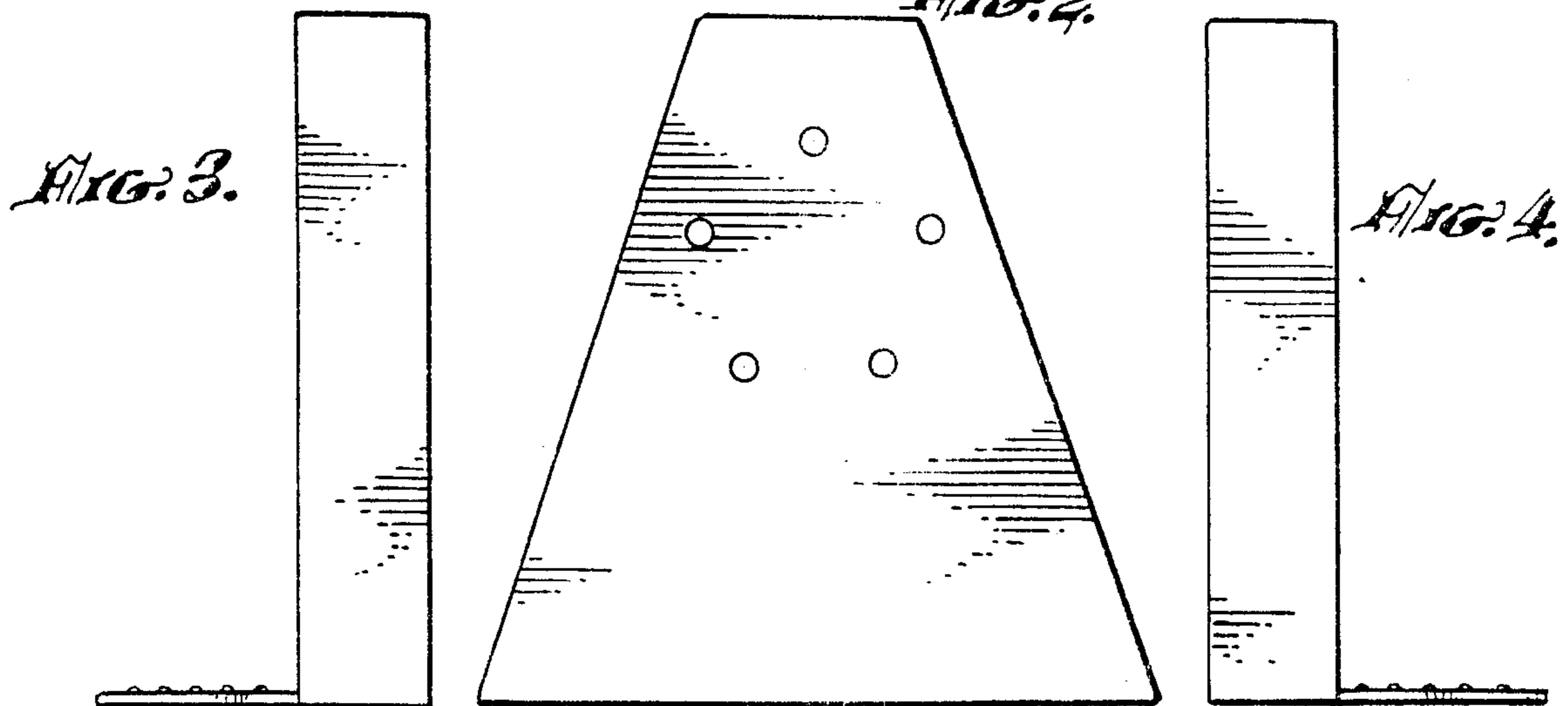
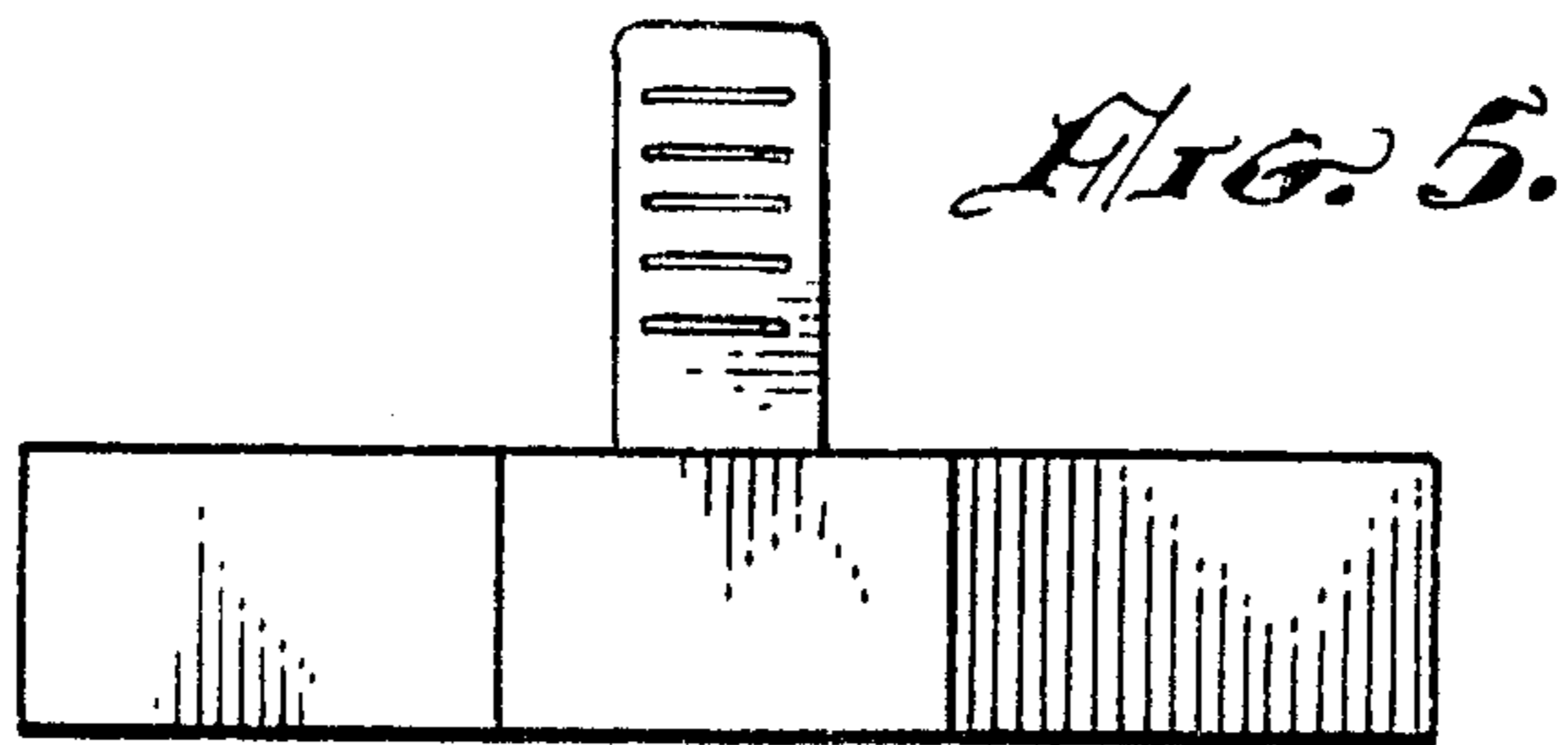
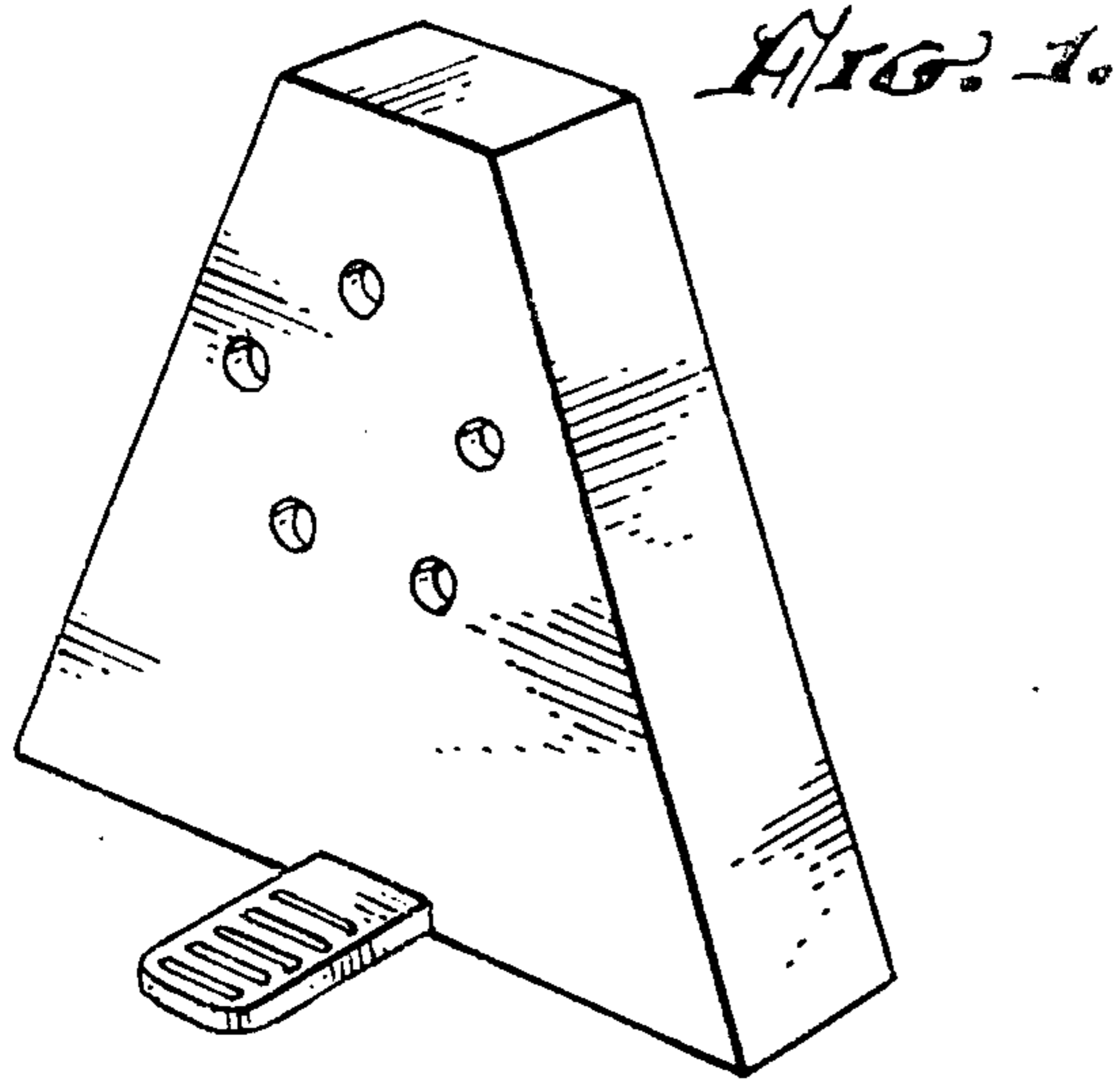

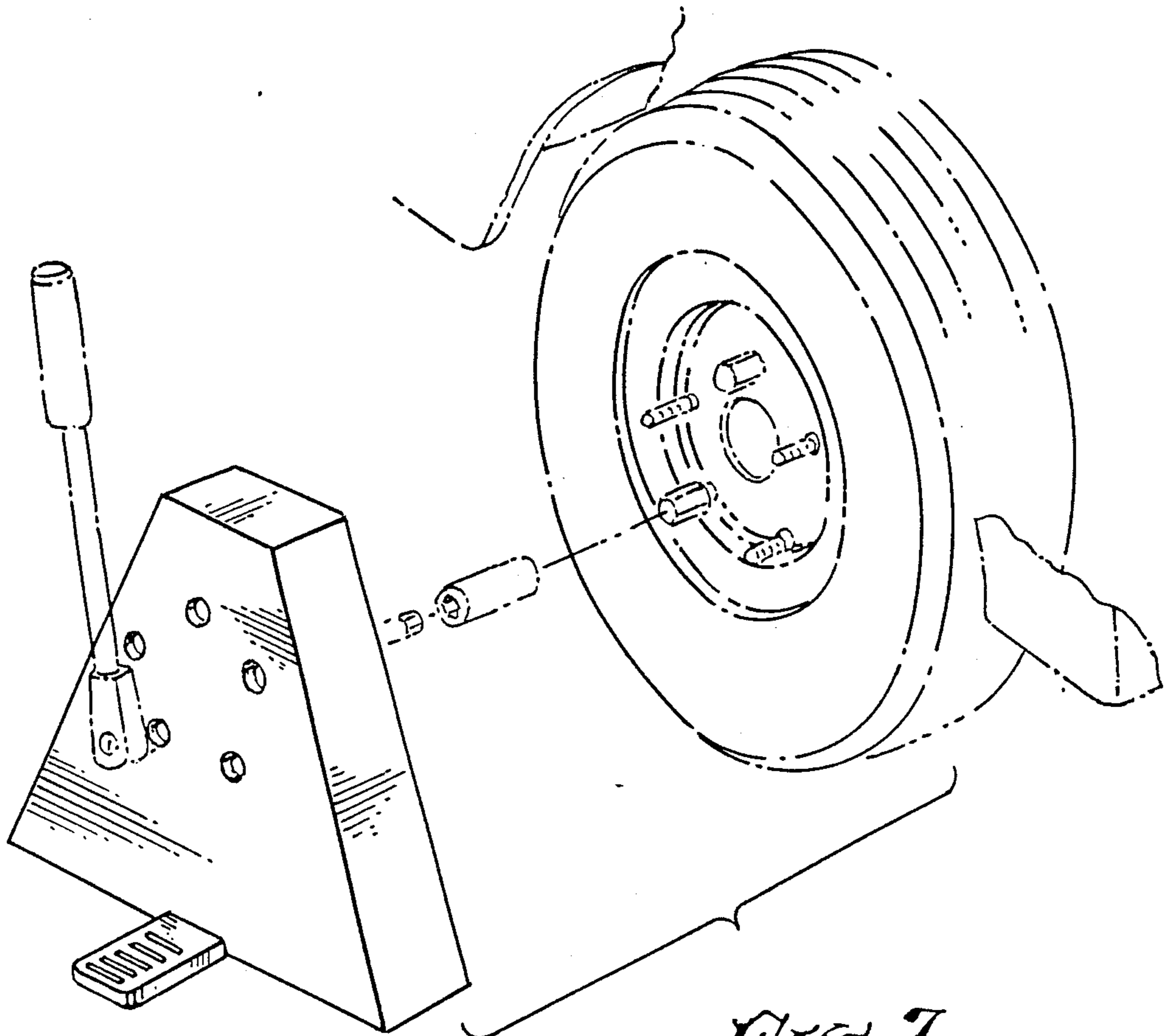

FIG. 7.