

[54] MOTORCYCLE

[75] Inventors: Toshiaki Kishi, Tokyo; Shusei Sudoh, Yokohama; Masaharu Yoshimura, Asaka, all of Japan

[73] Assignee: Honda Giken Kogyo Kabushiki Kaisha, Tokyo, Japan

[\*\*] Term: 14 Years

[21] Appl. No.: 146,150

[22] Filed: Jan. 19, 1988

[30] Foreign Application Priority Data

Jul. 20, 1987 [JP] Japan ..... 62-29426

[52] U.S. Cl. .... D12/110

[58] Field of Search ..... D12/110; 180/219

[56] References Cited

U.S. PATENT DOCUMENTS

D. 295,028 4/1988 Huamatsu ..... D12/110  
4,828,069 5/1989 Hatsuyama ..... 180/219

OTHER PUBLICATIONS

Cycle World, Oct. 1987, p. 21, Aprilia G.P. Motorcycle.

Cycle World, Aug. 1987, front cover page, Honda HRC Motorcycle.

Cycle World, Mar. 1987, p. 103, Kawasaki RLR658 Motorcycle.

Cycle World, Apr. 1985, pp. 128 & 129, Honda Sabre Motorcycle.

Primary Examiner—James M. Gandy

Assistant Examiner—Melody N. Brown

Attorney, Agent, or Firm—Armstrong, Nikaido,

Marmelstein, Kubovcik & Murray

[57] CLAIM

The ornamental design for a motorcycle, as shown.

DESCRIPTION

FIG. 1 is a right side-front perspective view of a motorcycle showing my new design;

FIG. 2 is a top plan view thereof;

FIG. 3 is a rear perspective view thereof;

FIG. 4 is a front perspective view thereof;

FIG. 5 is a right side elevational view thereof; and

FIG. 6 is a left side elevational view thereof.

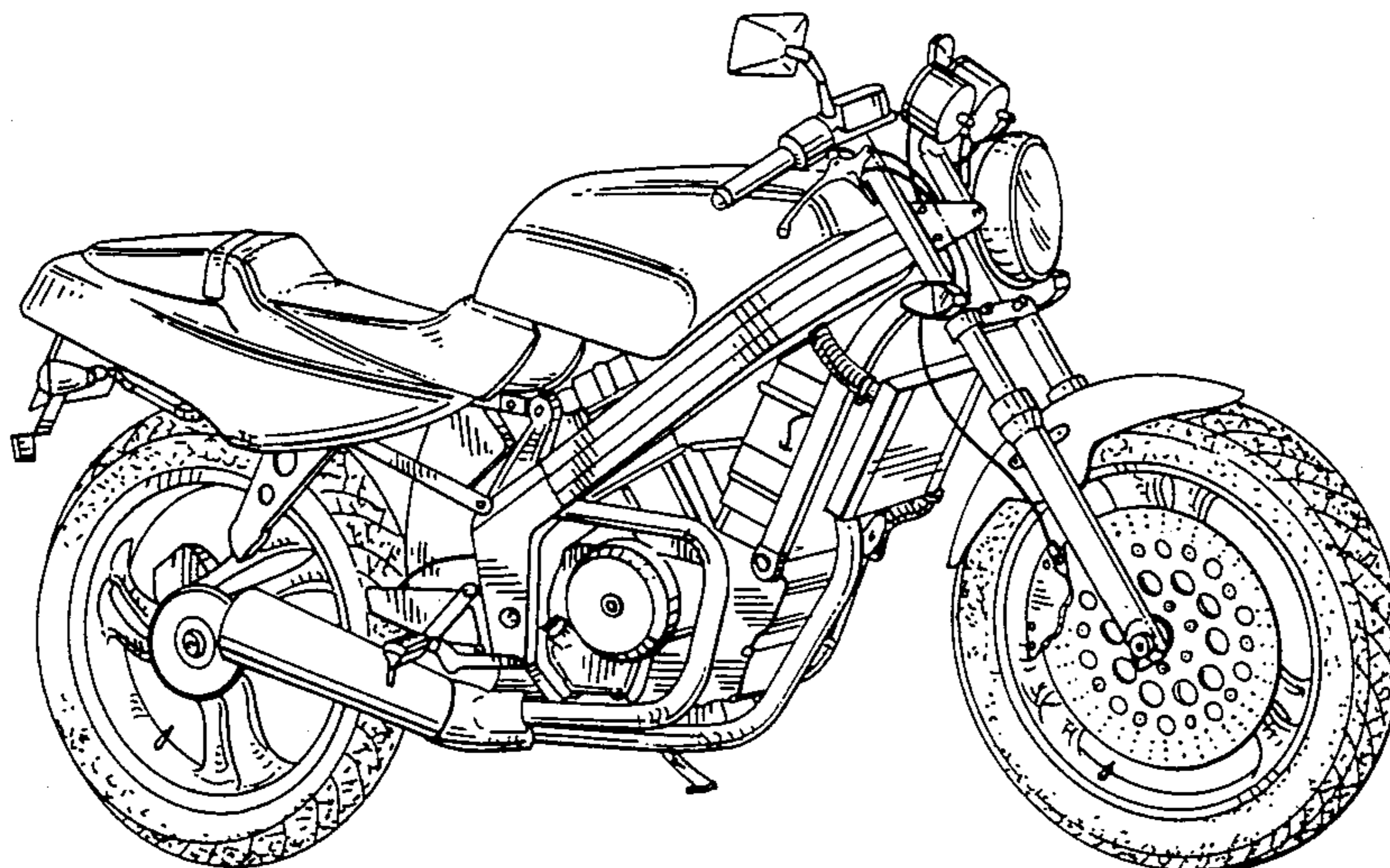

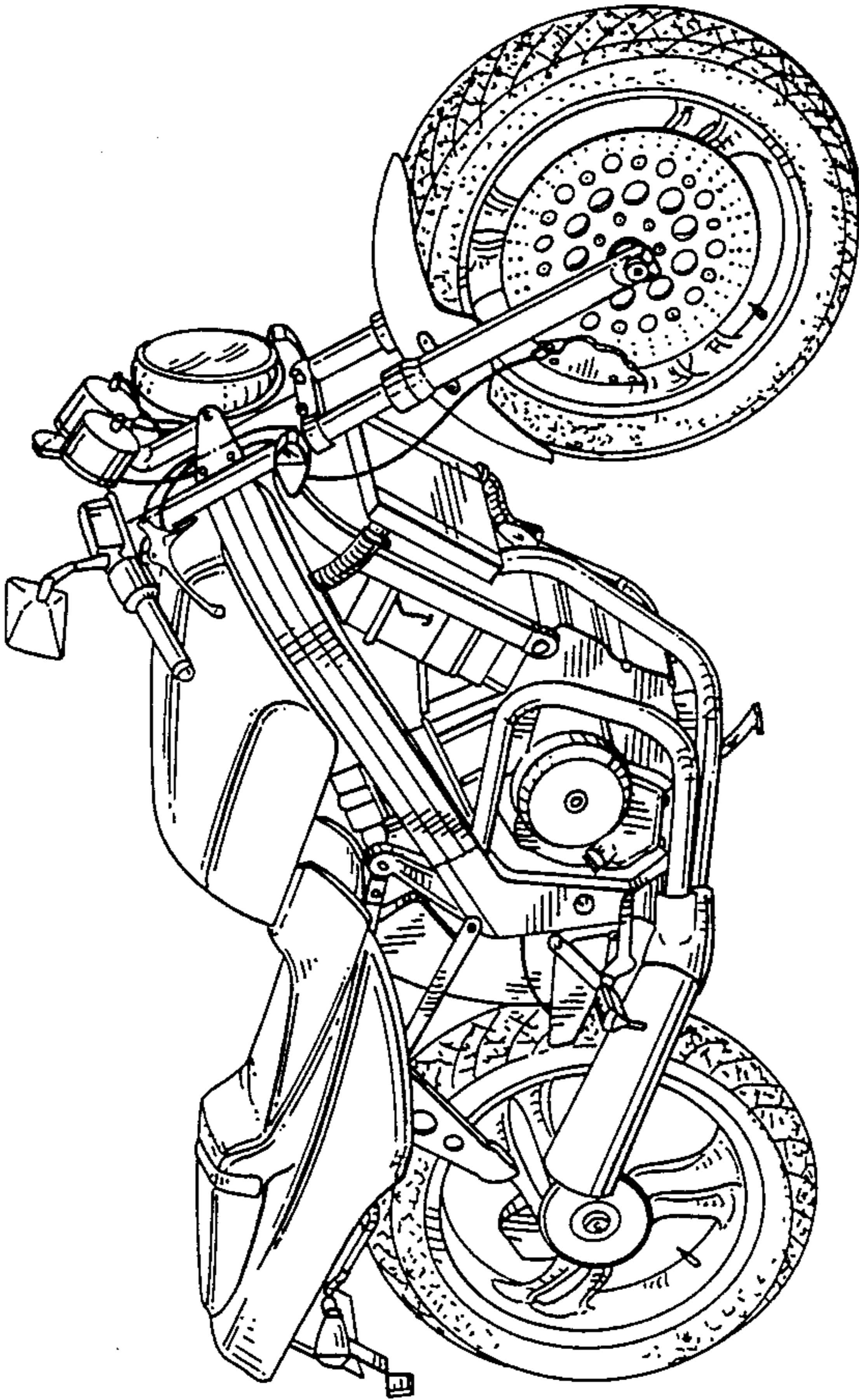

FIG. 1

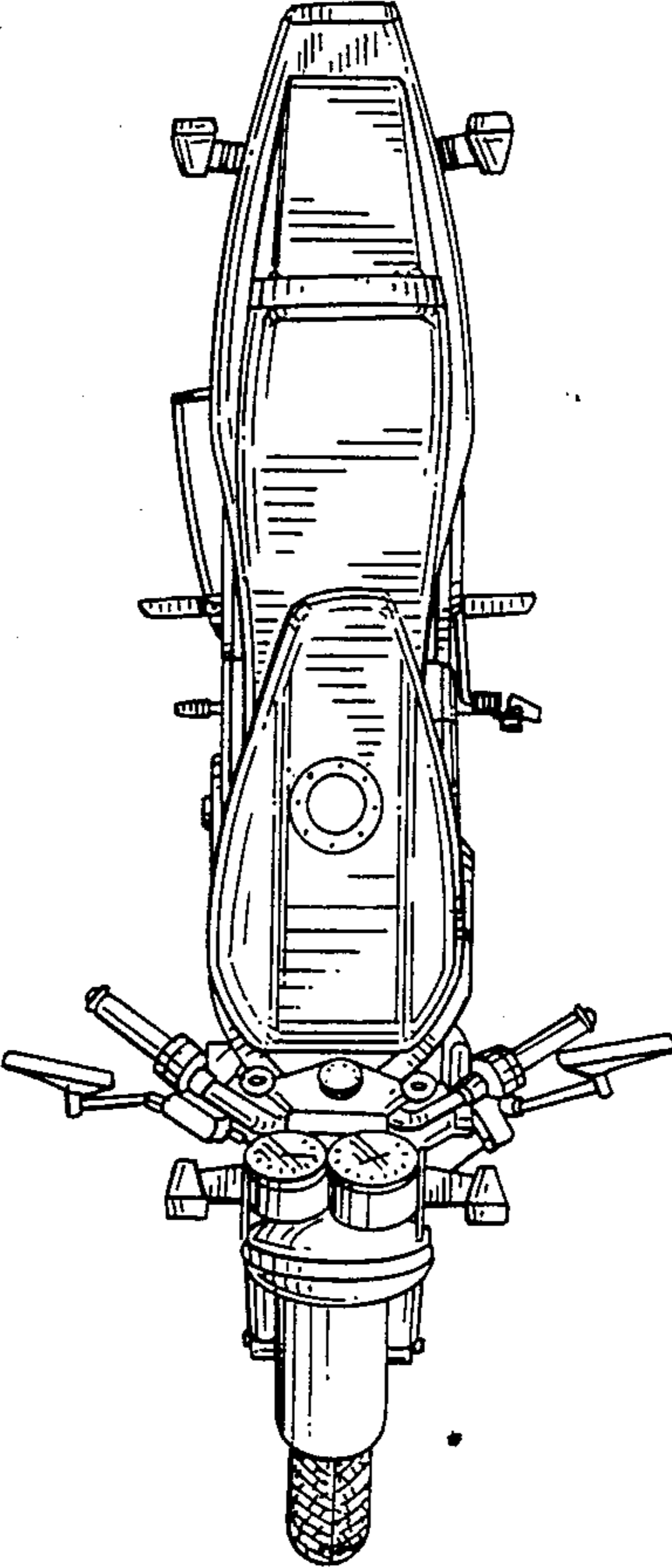

FIG. 2

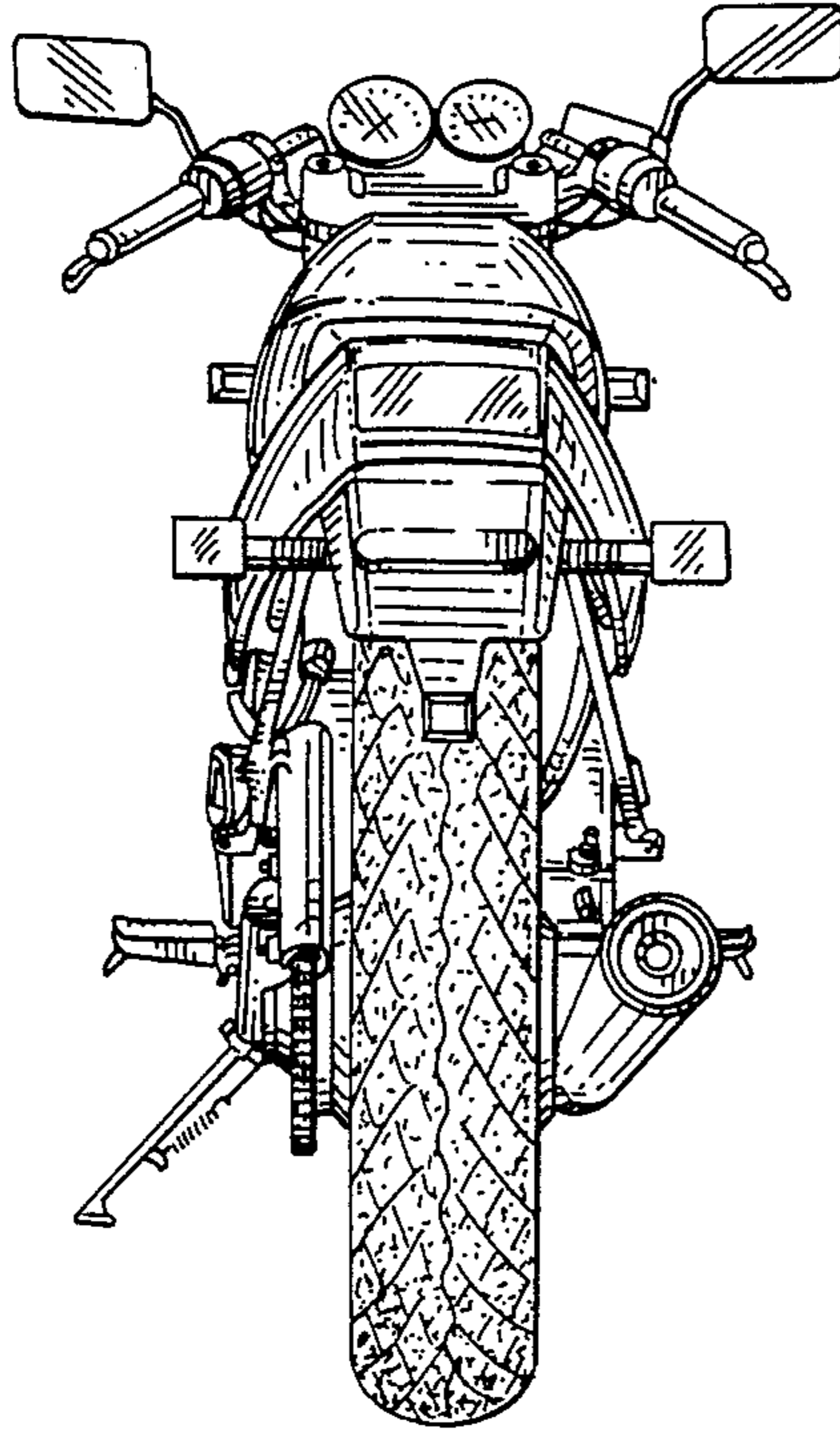

FIG. 3

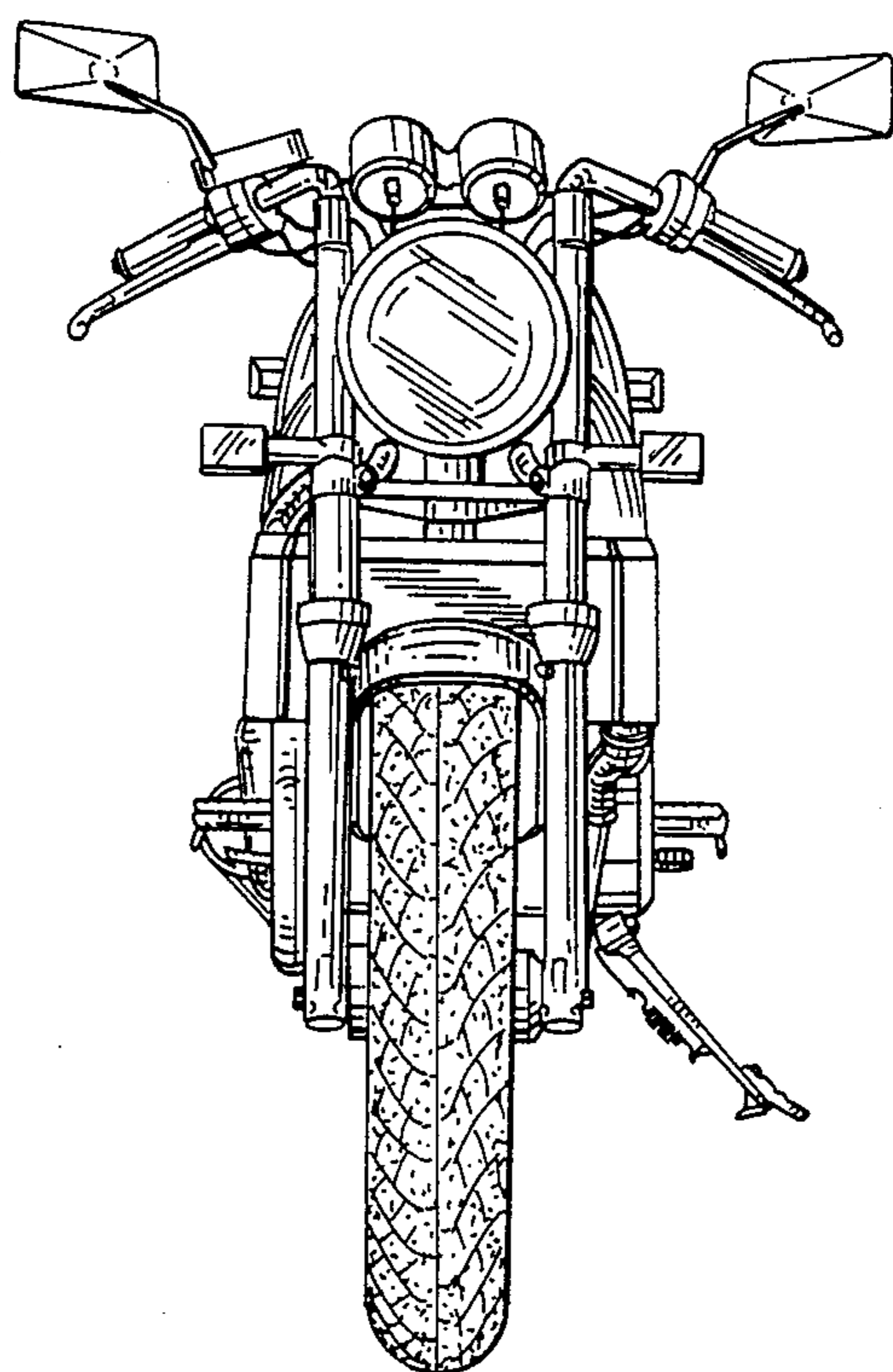

FIG. 4

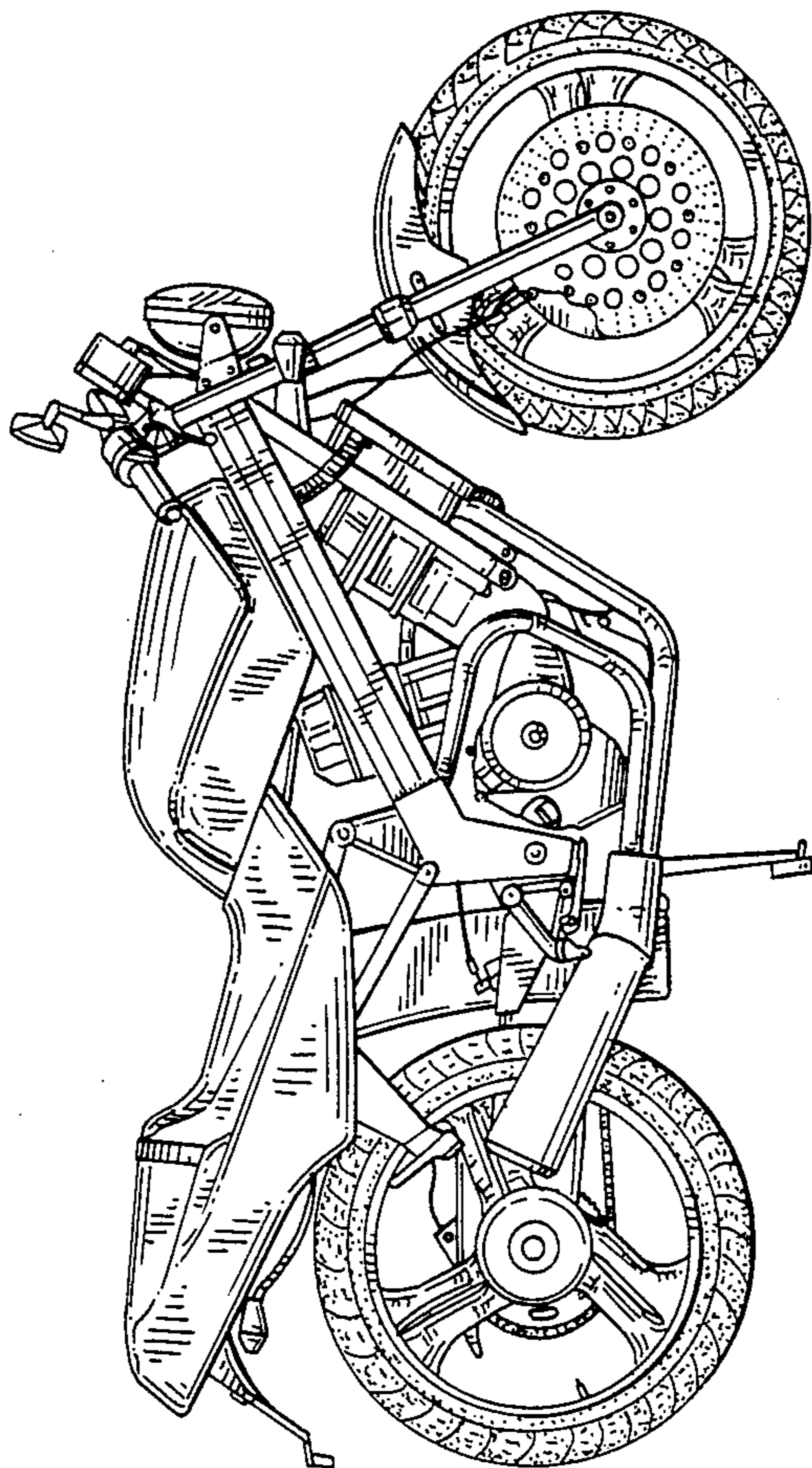

FIG. 5

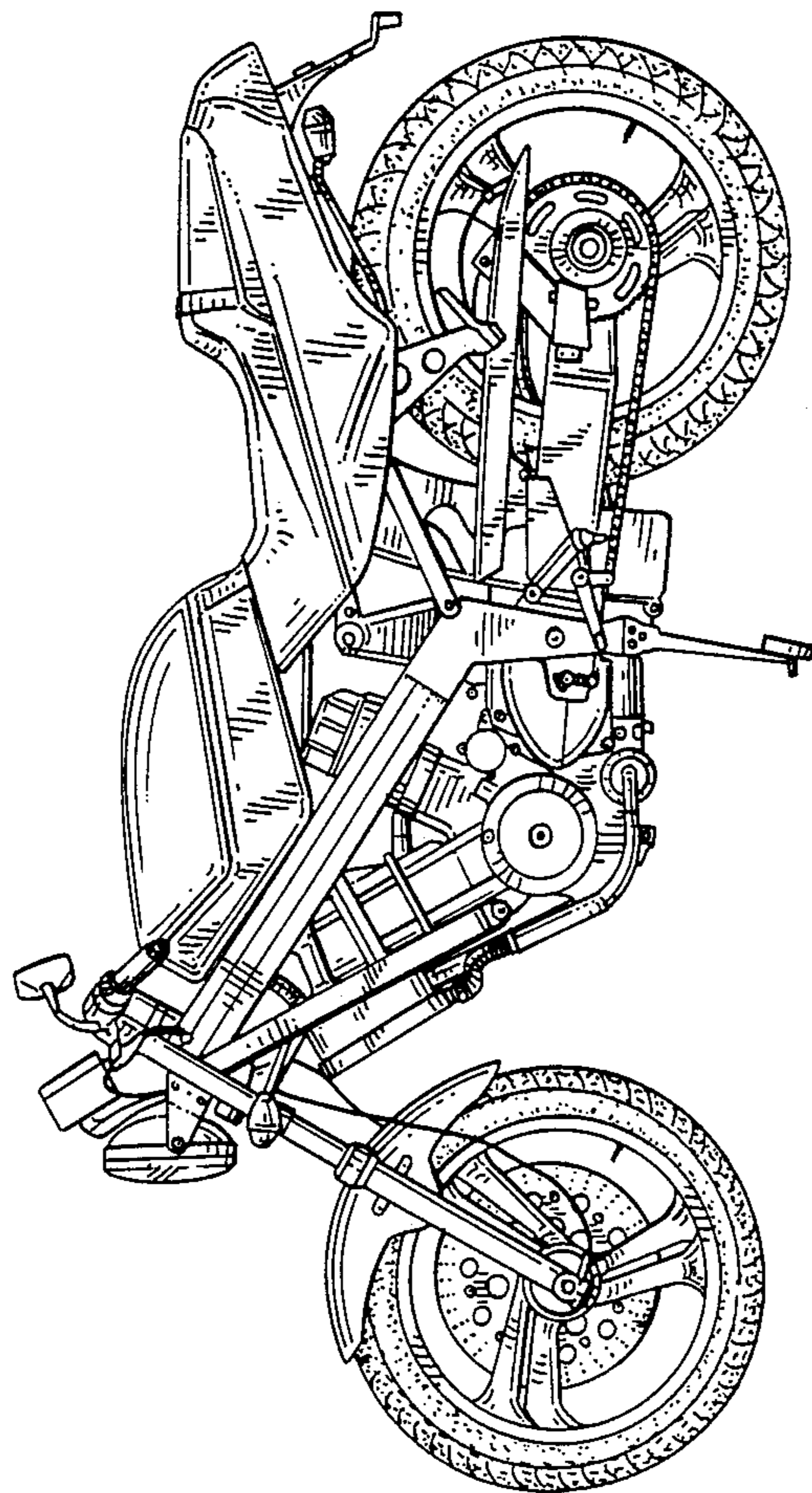

FIG. 6